



# PV SERIES E, J & L PISTON PUMP INSTALLATION TIPS AND PROCEDURES

## OIL RECOMMENDATIONS

Do not use automatic transmission fluid (ATF), bio-degradable oil, or fire resistant fluids due to the poor lubricating properties. A good quality petroleum based fluid is recommended. Muncie does not promote specific manufacturer's brands of oil. Below are recommended oil viscosity guidelines. Your oil supplier should be consulted for your application needs.

Maximum viscosity at startup: 4,700 SUS

Recommended viscosity range for optimum performance: 58-500 SUS

Typical operating range: 75-1,000 SUS

## FILTRATION

Because the design and operation of a piston pump is considerably different than that of a normal gear pump, filtration and contamination control must be improved for optimum product life and performance. Disregarding this portion of the system can lead to catastrophic pump failure and/or inadequate system performance. It is recommended that fluid contamination levels be equal to or better than ISO 4406-1999 class -22/18/13. Most new oils will need to be filtered to meet this requirement.

If inlet side filtration is used, care must be used to determine proper size and capacity to prevent possible high vacuum conditions to the pump. Types of fluid, duty cycles, pump displacement and operating speeds help determine proper filter. A 150 mesh screen with 3 PSI bypass is recommended. See below for other information on the pump inlet.

## PUMP CASE DRAIN

Maximum case pressure is limited to 7 PSI (0.5 BAR) to prevent shaft seal damage and sluggish response. Never plug or block the case drain. Doing so will result in shaft seal and/or possible case damage. Route directly back to the reservoir. Keep line below the oil level at all times. Keep away from the reservoir's outlet port.

## SHAFT LOADING

Axial and radial loading is not recommended and should be avoided. Do not use with pulleys and drive belts without other support. The drive shaft assembly should provide adequate slip to prevent end loading.

## PUMP MOUNTING AND INSTALLATION

As with all drive shaft driven components, the pump should be mounted at the same angle as the engine. Never mount the pump parallel to the chassis frame. The crankshaft centerline must be parallel to the pump shaft centerline within 1.5 degrees to prevent harmonic noise and premature PTO, pump, or driveline failure. The two shafts should have an offset of 1-3 degrees to properly load and lubricate the drive shaft cross and bearings. End and slip yokes must be in phase and balancing of the assembly is recommended. Never use solid shafting for this type of drive. The pump can be mounted in any position except vertical which could cause the input bearing to be run dry. You may have difficulty in filling the pump case with oil with the case drain port positioned down. With pump mounted, route the case drain hose back into the tank through a separate unrestricted passage that will stay below the oil level at all times. Direct mounting to PTO's require a support bracket to carry the pump weight. Check with the PTO manufacturer on this limitation. If mounting to an electric or gasoline motor, shaft alignment between the two must be within .010 in. TIR and no end load should be applied.

## OTHER INSTALLATION TIPS

- Always use the appropriate SAE rated hose for each part of the system.
- When routing and plumbing the inlet side of the pump, avoid sharp 90 degree bends of any type. Smooth sweeps and 45 degree elbows will help prevent restrictions to the pump.

- Cycle the system under no load conditions to purge any entrained air.
- Change the filter element after the first 40 hours of service. Regular maintenance usually thereafter.

## PUMP LAYOUT

See illustration on page 2.

## HOSE SIZES

Hose should follow SAE guidelines for appropriate type and size needed for the given flow rate (velocity) and function. Careful consideration should be made on the inlet hose size. The inlet hose should be 2 in. ID. minimum but some applications may need a larger size.

## PUMP INLET

Due to the nature of design and operation of a piston pump, care must be taken to prevent operation at high vacuum conditions. The piston pump is more susceptible to damage and premature wear than a typical gear pump due to port design, tighter tolerances, and the numerous contact surfaces. Most load sense applications do not operate under conditions that require both maximum speed and maximum pump displacement at the same time. This is helpful in determining the proper size inlet line. Inlet line velocity should not exceed four feet per second. Pressurizing the reservoir to approximately 3-5 PSI can help decrease the chances of high vacuum conditions and cavitation damage in most cases. Maximum 30 in. (76cm) vertical lift (difference of fluid level in reservoir and pump inlet port).

All inlet connections must be air tight to prevent the possibility of drawing air into the inlet oil and to prevent the draining of oil out of the inlet line when the vehicle is shut down.

## START UP PROCEDURES

With the system installation complete and the reservoir filled with clean oil, the following is recommended.

- Remove the case drain plug and fill case with clean oil. Make sure case drain hose is routed back to the reservoir.
- With the inlet fitting slightly loose at the pump, pressurize the reservoir until a steady stream of oil is noticed, tighten fitting with stream still running if possible.
- Start the vehicle and let the engine idle with pump running for approximately five minutes to purge air out and flush out any contaminants. Look for leaks or any other problems.
- Do not run pump longer than 30 seconds if it does not prime itself.
- Cycle the cylinder or motor functions under no load (do not bottom or dead head) to fill with oil and to purge out the air. Monitor the oil level and refill as needed. Watch for leaks or any other problems.
- Once the system is filled and air purged, set any relief valves or compensators as needed.
- Some systems are in a dead head condition at startup. An air bleed valve can be used to momentarily unload the pump for a few seconds to prevent prime mover damage or high horsepower requirements.

## SYSTEM PROTECTION

To protect the hydraulic system from pressure spikes a standard high quality in line relief valve must be used (typically installed in the directional valve) and set higher than the pump's pressure compensator.

## LOAD SENSE CONTROL

The PV series pump does have an adjustable compensator for pressure control. Screw in (CW) to increase and Screw out (CCW) to decrease. The standard setting is 2,610 PSI (180 Bar). See Pump Layout section for reference drawing.

## DISPLACEMENT CONTROL

The PV series pumps do have screw adjustment displacement limiters available. Limiters are optional on all series. Screw in (CW) to limit swash plate angle and subsequent discharge output flow. Screw out (CCW) to increase angle and output flow.

## TEMPERATURE RANGE

Maximum temperature should not exceed 220°F (104°C) intermittent, 180°F (82°C) continuous measured at the pumps case drain return oil. See oil recommendations for typical operating ranges.

## PUMP ROTATION

All PV series pumps are uni-rotational. The large port is the pump inlet and

smaller port is the pressure discharge. To determine actual rotation, view the pump rotation arrow on the rear cover casting. Pump rotation cannot be changed in the field. See Pump Layout section for reference drawing.

## PORTING

| PUMP MODEL | INLET PORT | OUTLET PORT      | PUMP CONTROLS | CASE DRAIN | GAUGE PORT |
|------------|------------|------------------|---------------|------------|------------|
| PVL        | -24 ODT    | -16 ODT          | -4 ODT        | -10 ODT    | -6 ODT     |
| PVJ        | 2" SF      | 1" SF            | -4 ODT        | -10 ODT    | -6 ODT     |
| PVE        | 2½" SF     | 1¼" SF (CODE 62) | -4 ODT        | -12 ODT    | -6 ODT     |

Note: Porting sizes are shown for standard model codes. See Pump Layout section for reference drawing and location.

## PUMP SPECIFICATIONS

| PUMP MODEL | CU IN DISPL (CC) | MIN RPM | MAX CONT. PSI (BAR) | MAX INT. PSI (BAR) | MAX RPM* | APPROX WT LBS (KG) |
|------------|------------------|---------|---------------------|--------------------|----------|--------------------|
| PVL030     | 1.83 (30)        | 500     | 3,045 (210)         | 4,350 (300)        | 3,200    | 53 (24)            |
| PVJ045     | 2.75 (45)        | 500     | 4,495 (310)         | 5,800 (400)        | 2,800    | 58.8 (26.7)        |
| PVJ060     | 3.66 (60)        | 500     | 4,495 (310)         | 5,800 (400)        | 2,600    | 58.8 (26.7)        |
| PVJ075     | 4.58 (75)        | 500     | 3,770 (260)         | 5,075 (350)        | 2,400    | 58.8 (26.7)        |
| PVE100     | 6.10 (100)       | 500     | 4,495 (310)         | 5,800 (400)        | 2,450    | 121 (54.9)         |
| PVE130     | 7.93 (130)       | 500     | 4,495 (310)         | 5,800 (400)        | 2,200    | 121 (54.9)         |
| PVE147     | 8.97 (147)       | 500     | 3,770 (260)         | 5,075 (350)        | 2,100    | 121 (54.9)         |

Note: Maximum case drain pressure is 7 PSI (0.5 Bar).

\*RPM shown for continuous speeds at 0 In.HG (1 Bar Absolute) inlet condition, maximum pump displacement.

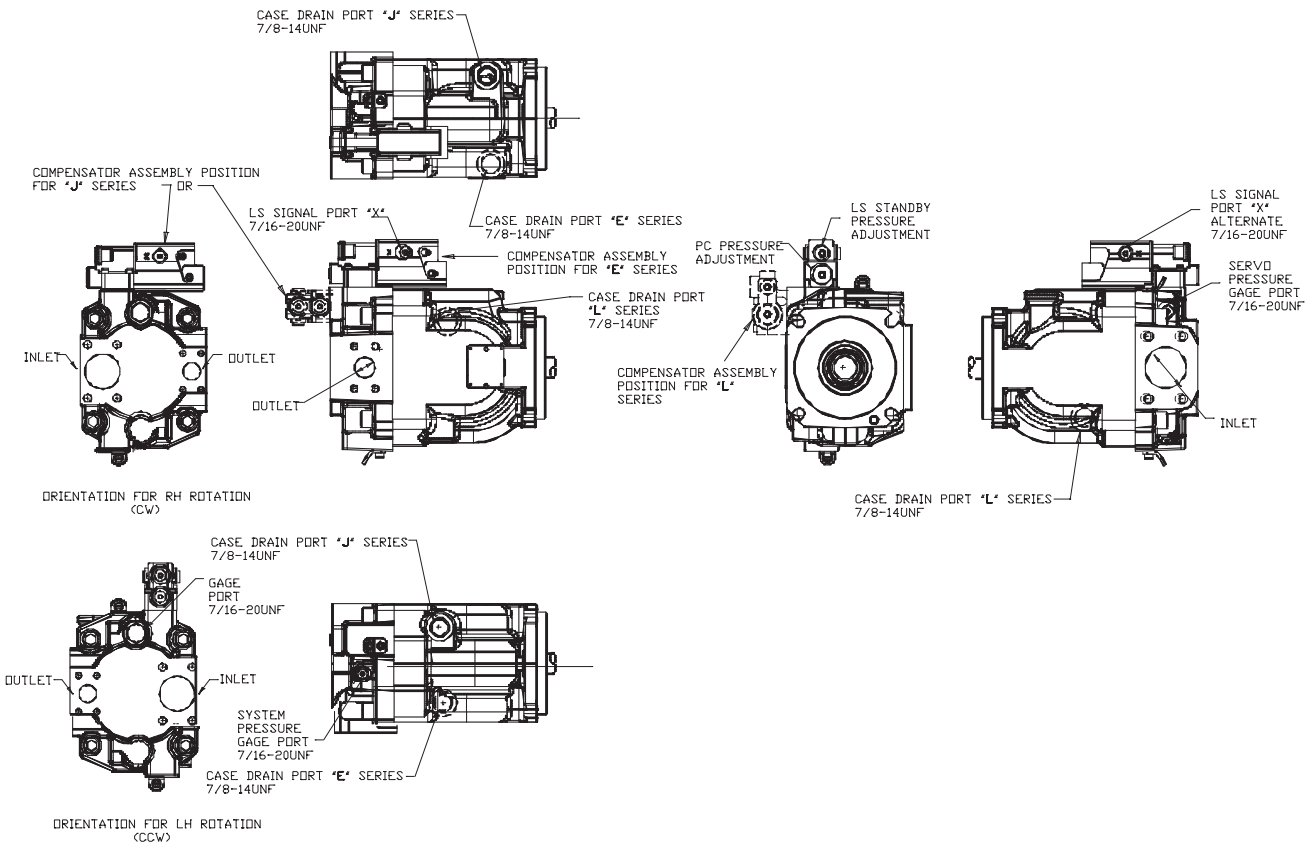

Muncie Power Products, Inc. General Offices & Distribution Center • P.O. Box 548 • Muncie, IN 47308-0548  
 765-284-7721 • FAX 765-284-6991 • Email info@munciepower.com • Web www.munciepower.com  
 Drive Products, Inc., Toronto, Exclusive Agents for Canada