

OPTIMUM X SERIES

GEAR PUMPS



DESIGNED FOR OPTIMUM PERFORMANCE

The Optimum X Series gear pumps/motors offer premier performance for a wide variety of applications across several industries. Featuring the innovative OPTI-Grip® technology, the Optimum X Series exemplifies strength, endurance, and rigidity making for long-lasting units even in the most extreme conditions. The X Series is the middle range of the Optimum group, providing nine displacements to cover medium to heavy flow, and high pressure requirements.

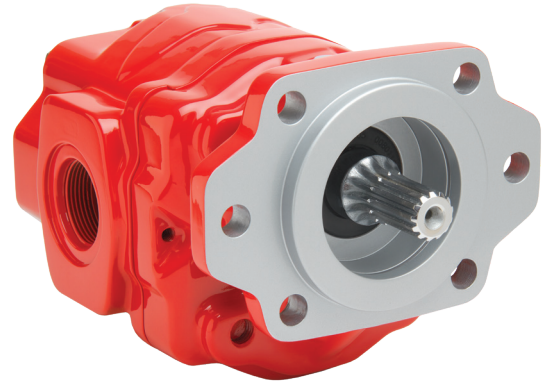

KEY FEATURES

- 9 pump displacements available
- OPTI-Grip (patented design)
- Long life, high-performance bushings
- Noise reducing, quiet design
- Bi-rotational, 4-port design standard (SAE straight thread only)
- Pressures up to 4,350 PSI (300 BAR)
- Speeds up to 3,000 RPM
- High-quality, tested design
- Additional features & benefits

PUMP SPECIFICATIONS

MODEL NUMBER	DISPLACEMENT IN ³ (CC)	MAX* RPM	MIN* RPM	MAX PRES PSI (BAR)	PORTS (ODT) SIDE & REAR	PORTS (SF) SIDE ONLY	WEIGHT LBS (KG)
X14	3.18 (52.1)	3,000	800	4,350 (300)	-20	2.0" X 1.25"	52.9 (24.0)
X16	3.83 (62.9)	3,000	600	4,350 (300)	-20	2.0" X 1.25"	54.7 (24.8)
X19	4.44 (72.8)	3,000	600	3,750 (260)	-24	2.0" X 1.25"	55.9 (25.3)
X23	5.20 (85.3)	2,750	600	3,500 (240)	-24	2.0" X 1.25"	58.0 (26.3)
X25	5.69 (93.4)	2,750	600	3,250 (225)	-24	2.0" X 1.25"	59.3 (26.9)
X27	6.35 (104)	2,500	600	3,000 (210)	-24	2.0" X 1.25"	61.1 (27.7)
X30	7.01 (115)	2,500	600	2,500 (190)	-24	2.0" X 1.5"	62.9 (28.5)
X33	7.78 (128)	2,500	600	2,500 (190)	-24	2.0" X 1.5"	65.0 (29.5)
X36	8.43 (138)	2,250	600	2,250 (155)	-24	2.0" X 1.5"	67.0 (30.4)

Notes:

- MAX RPM is shown at 0 in.Hg., and with an appropriately sized inlet hose
- MAX motor back pressure is not to exceed 150 PSI (10 BAR)
- MAX inlet vacuum is not to exceed 5 in.Hg. (0.17 BAR)
- Weights shown are for single, direct mount pumps
- Porting shown is standard pump porting, other porting configurations are available
- Motor applications will require a case drain to be plumbed directly back to the reservoir due to excessive return line pressures or surges

The 3-D diamond-like design appearing on Muncie Power's hydraulic pumps is a trademark of Muncie Power Products, Inc., Muncie, Indiana (USA), registered in the United States and various foreign countries.

DIRECT MOUNT DIMENSIONS

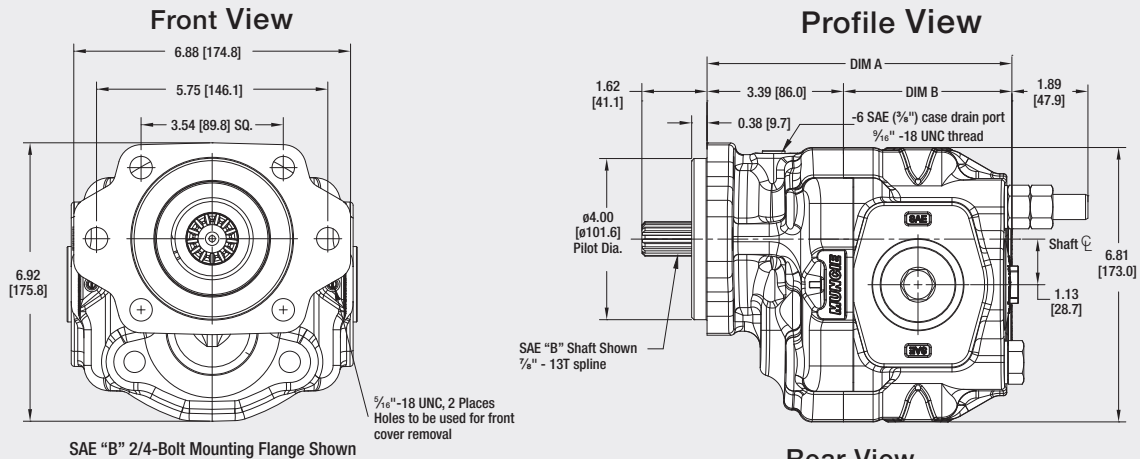

MODEL	DIM A	DIM B
X14	7.33 [186.2]	3.94 [100.2]
X16	7.57 [192.2]	4.18 [106.2]
X19	7.78 [197.7]	4.40 [111.7]
X23	8.06 [204.7]	4.67 [118.7]
X25	8.24 [209.2]	4.85 [123.2]
X27	8.47 [215.2]	5.09 [129.2]
X30	8.71 [221.2]	5.32 [135.2]
X33	8.98 [228.2]	5.60 [142.2]
X36	9.22 [232.2]	5.83 [148.2]

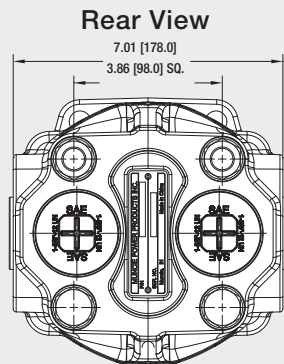

SAE "C" 4-Bolt Mounting Flange Shown with SAE "C" 1.25" - 14T shaft

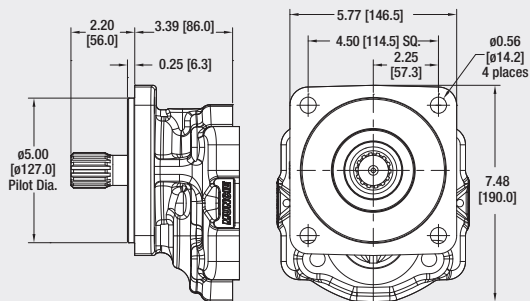

Muncie Power's Remote Mount "R" Mounting Flange Shown with SAE "BB" 1.0" round shaft

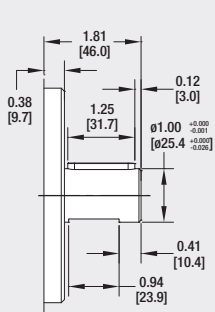
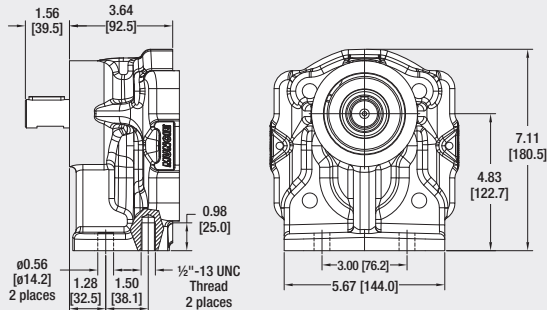

SHAFT CODE 01
SAE "BB" 1.0" Rd.
Shaft with 1/4" key
NOTE: SAE "B" pilot shown

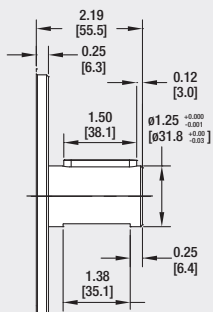

SHAFT CODE 07
SAE "C" 1.25" Rd.
Shaft with 5/16" key
NOTE: SAE "C" pilot shown

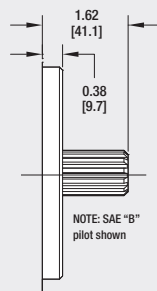

SHAFT CODE 02
SAE "B" 7/8" - 13T Spline
• SAE external involute spline
• 7/8" nominal diameter, 13 teeth
• 16/32 diametrical pitch
• Flat root side fit
• Major diameter = 0.853" - 0.858" [21.67 - 21.80mm]
• Minor diameter = 0.721" - 0.732" [18.32 - 18.60mm]

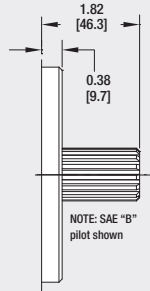

SHAFT CODE 17
SAE "BB" 1.0" - 15T Spline
• SAE external involute spline
• 1.0" nominal diameter, 15 teeth
• 16/32 diametrical pitch
• Flat root side fit
• Major diameter = 0.978" - 0.983" [24.84 - 24.97mm]
• Minor diameter = 0.847" - 0.858" [21.52 - 21.80mm]

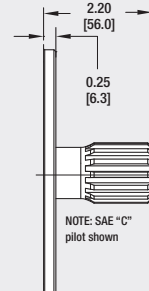

SHAFT CODE 05
SAE "C" 1.25" - 14T Spline
• SAE external involute spline
• 1.25" nominal diameter, 14 teeth
• 16/32 diametrical pitch
• Flat root side fit
• Major diameter = 1.223" - 1.228" [31.06 - 31.19mm]
• Minor diameter = 1.049" - 1.063" [26.66 - 26.99mm]

OPTI-GRIP® DESIGN

The future of gear pump technology

The Optimum Series' integral, two piece castings are press fit together for greater structural integrity over other traditional designs.

Muncie Power's OPTI-Grip technology allows for higher pressure capabilities and a more rigid pump design for long life and maintained performance.

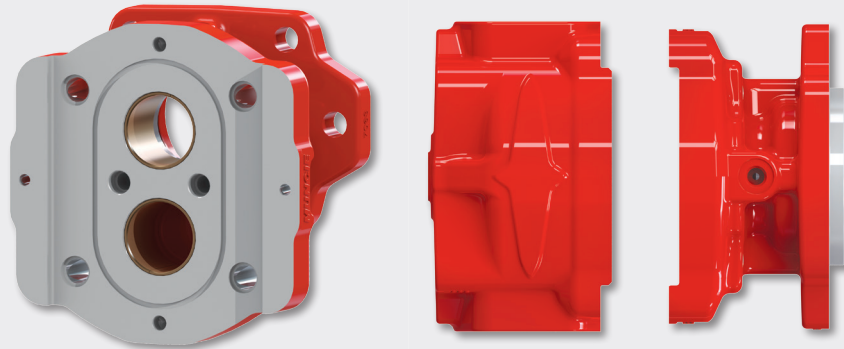

MODEL NUMBER CONSTRUCTION

X-23-02-B-J0-HE HE-A-1-5-T0-23-HE

For multiple units only. Delete for single units or repeat for triple units.

Series: X

GPM (LPM) @ 1,000 RPM, 1st unit:

14 (53), 16 (60), 19 (72), 23 (87), 25 (95),
27(102), 30 (114), 33 (125), 36 (136)

Shaft Size & Type

- 01* - SAE "BB" 1.0" round shaft w/ ¼ key
(25.4 round w/6.35 key)
- 02 - SAE "B" 7/8"-13T spline
- 05 - SAE "C" 1¼"-14T spline
- 07* - SAE "C" 1¼" round w/ 5/16 key
(31.75 round w/ 7.94 key)
- 17 - SAE "BB" 1.0"-15T spline

Mounting Flange & Type:

- B - SAE "B" 2/4-Bolt, 4" Pilot Dia.
- C - SAE "C" 4-Bolt, 5" Pilot Dia.
- R - Remote Foot Mount

Mounting Flange configuration*:

Bi-rotational internals (pump or motor)

- J0 - bi-rot, w/o O.B. Bearing, w/ -6 SAE (3/8") drain
- J1 - bi-rot, w/ O.B. Bearing, w/ -6 SAE (3/8") drain

Uni-rotational internals (pump or motor)***

- K0 - CW without O.B. Bearing, w/ -6 SAE (3/8") drain
- K1 - CCW without O.B. Bearing, w/ -6 SAE (3/8") drain
- K2 - CW with O.B. Bearing, w/ -6 SAE (3/8") drain
- K3 - CCW with O.B. Bearing, w/ -6 SAE (3/8") drain

Side Ports, 2nd Unit:

See "side ports, 1st section" for codes

GPM (LPM) @ 1,000 RPM, 2nd Unit:

See "GPM (LPM) @ 1,000 RPM,
1st unit" for codes

Thru Drive (Multiple Units Only):

- T0 - No thru ports
- T1 - CW thru port configuration (inlet port)
- T2 - CCW thru port configuration (inlet port)

Assembly Sections:

- 4 - Single unit, with extended studs
- 5 - Tandem unit, with extended studs
- 6 - Triple unit, with extended studs

Design Number: 1

Additional Attributes:

- A - High pressure shaft seal**
- W - Double seal for wet spline

Rear Ports, Size & Type:

SAE Ports

- GT - SAE-20 x SAE-20 (X14-16)
- HE - SAE-24 x SAE-24 (X19+)

Split Flange Ports

- XX - No rear ports

Side Ports, 1st Section:

SAE Ports

- GT - SAE-20 x SAE-20 (X14-16)
- HE - SAE-24 x SAE-24 (X19+)

Split Flange Ports***

- JC - 2.00" SF x 1.25" SF (X14-27)
- JD - 2.00" SF x 1.50" SF (X30+)

* It is recommended that pumps or motors with a round output shaft use an outboard bearing to assist with radial loads.

** 150 PSI MAX back-pressure

*** Uni-rotational internals (K configuration codes) are used with split flange ports only

OPTIMUM SERIES GENERAL INFORMATION

Oil Recommendations

Muncie Power Products does not promote specific manufacturer's brands of oil, but does recommend the use of quality petroleum-based hydraulic fluids. Different climate temperatures require that the oil viscosity be appropriate for the operating conditions. Consult the oil manufacturer for your exact application needs.

Note: NEVER dilute the hydraulic fluid for cold weather operation with, including but not limited to, diesel fuel, kerosene, etc.

- **Oil Viscosity:** 60-1,000 SSU (10.5-215 cSt) for continuous operation. Viscosity should not exceed 7,500 SSU (1,600 cSt) at start-up.
- **Special Fluids:** Biodegradable and water-glycol type fluids are acceptable for use with the Optimum Series Pumps/Motors.

Inlet/Outlet Condition

- Maximum inlet vacuum should not exceed 5 in.Hg. across all operating RPM's and temperature conditions.
- An undersized inlet port size could have maximum RPM limitations.
- An oversized outlet port size could have maximum pressure limitations.

Operating Temperatures

Proper control of the system operating temperature is critical for long product life and the protection of all other hydraulic components.

- Ideal operating temperatures: 100° F-140°F (37.8°-60° C)
- MAX Continuous temperature: 180° F (82.2° C)
- MAX Intermittent temperature: 200° F (93.3° C)

Hose Sizing

Hydraulic hose must be properly sized based on the oil velocity in feet per second (FPS) and of the appropriate type (SAE rating) for the specified rate of flow and pressure. The following are hose recommendations for common applications; hose requirements may differ for non-standard applications.

- Inlet hose: 2-4 FPS, SAE 100R4 type
- Pressure hose: 7-15 FPS, SAE 100R2 type
- Return hose: 4-8 FPS, SAE 100R1 type

Filtration Recommendations

Proper filtration is vital to the life of any hydraulic system since it helps protect hydraulic components from foreign objects which may have entered the system.

- **Return Line Filters:** Return filters are always recommended with a minimum 10 type micron rating. Some applications require better filtration with an absolute rating and possibly 3 or 6 micron media.
- **Pressure Filters:** Pressure filters are not typically required for gear pump applications, but they are available if desired.
- **Suction Strainers:** Suction strainers are very useful in catching large objects. Strainers should never be sized smaller than 100 mesh (149 micron), and should always include a 3 PSI (0.2 bar) bypass.

Oil Cleanliness Recommendations (ISO 4406-1999)

@ 2,000 PSI (138 bar): 20/17/15

@ 3,000 PSI (207 bar): 19/17/14

@ 4,000 + PSI (276 + bar): 17/15/12



**Muncie®
Power
Products**

A Member of the Interpump Group

MP15-14 (Rev. 11-19)

201 East Jackson Street • Muncie, Indiana 47305
800-367-7867 • Fax 765-284-6991 • info@munciepower.com • www.munciepower.com

Specifications are subject to change without notice. Visit www.munciepower.com for warranties and literature. All rights reserved. © Muncie Power Products, Inc. (2015)