



**Muncie[®]
Power
Products**

CMKD98-5900-P8-AC

1998-2002 Dodge D-250,350

5.9 I.S.B. Cummins Diesel

W-WO/AC

INSTALLATION NOTES

1. Disconnect the negative battery cables from both batteries. Remove fan clutch assembly using 1 7/16 wrench (14) provided, threads are left hand.
NOTE: Fan shroud does not need to be removed, take care not to damage radiator with fan.
2. Remove serpentine belt and fan pulley. Install drive pulley (1) with bolts and lockwashers (2 & 3).
3. Remove alternator from mounting bracket and lay aside. Remove upper alternator bracket and engine lifting lug. Remove bolt holding wire loom that crosses front of engine.
4. Install pump bracket (4) with bolts (7 & 10), leave bolts loose. Install alternator to bracket (4) with bolts (5 & 6). Tighten all bolts.
5. Install clutch pump (16) with bolts provided. Align clutch pulley with drive pulley (1), then tighten the pump bolts.
6. Install belt tensioner (13) on to the main bracket, using bolt (11) and lock washer (12).
7. Install O.E.M. serpentine belt, (trucks not equipped with A/C must have a new belt installed; Dayco #5080600 or equivalent-*not included in kit*). Install pump drive belt .
8. Re-route engine wire loom away from any moving parts and secure. Connect battery cables.

NOTE: Check all engine compartment vacuum hoses and electrical wiring that may have been disturbed or re-routed during kit installation to be sure that hoses are not kinked, that they do not touch any high temperature item, and that they do not interfere with any linkage components.

CMKD98-5900-P8-AC

1998-2002 Dodge Truck 250,350

5.9 I.S.B. Cummins Diesel

W-WO/AC

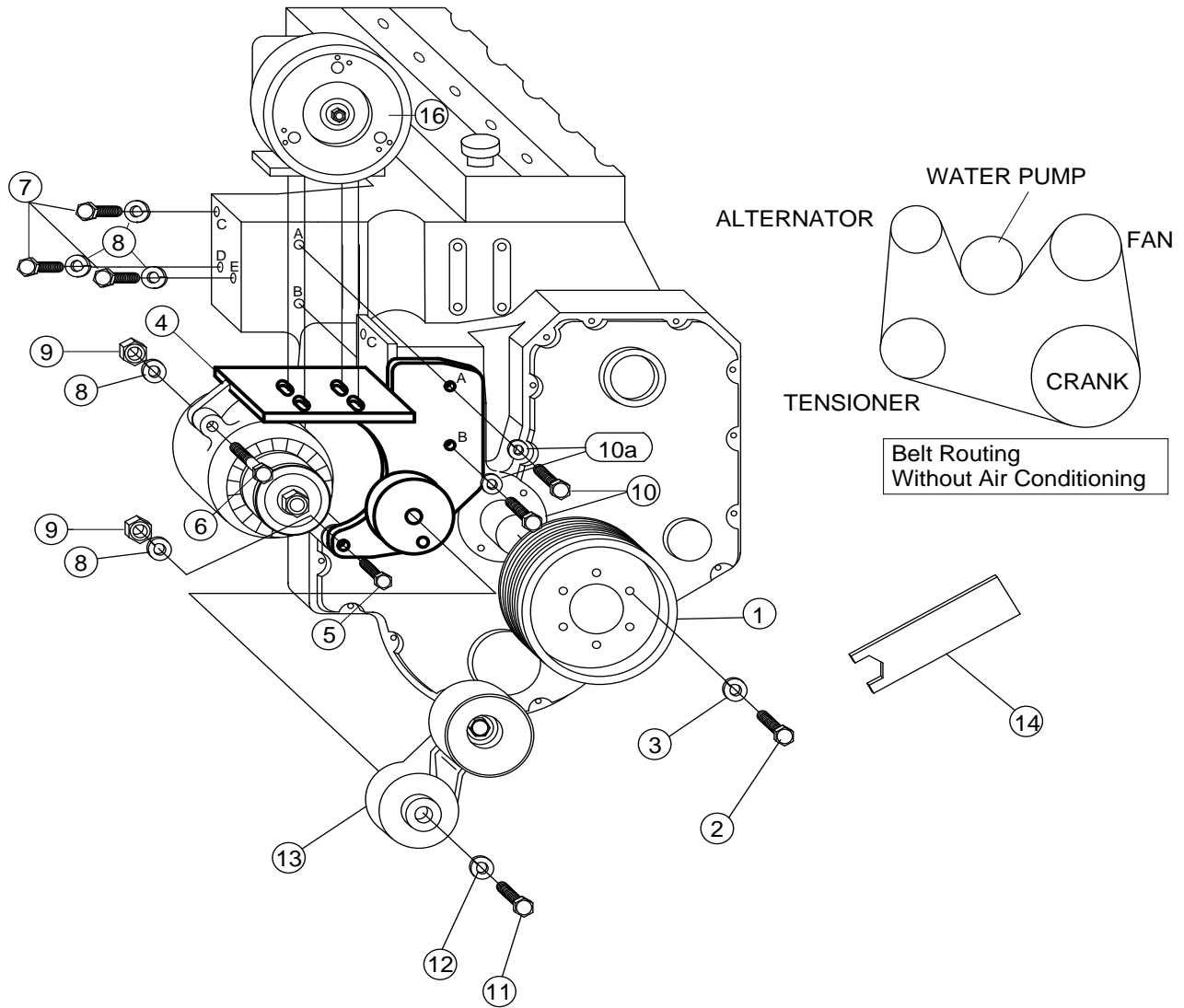

PARTS LIST

- | | |
|-------------------------|---|
| 1. DPC 518 (1) | 10. 8mm x 30mm 1.25 (2) |
| 2. 6mm x 16mm 1.0 (6) | 10a. 8mm LW (2) |
| 3. 6mm LW (6) | 11. 12mm x 80mm (1) |
| 4. DMP 548-1 (1) | 12. 12mm LW (1) |
| 5. 10mm x 120mm 1.5 (1) | 13. 89213016 |
| 6. 10mm x 60mm 1.5 (1) | (<i>Supersedes 89213007 & 89213 TIPCS</i>) |
| 7. 10mm x 30mm 1.5 (3) | 14. 1 7/16 Wrench (1) |
| 8. 10mm LW (5) | 15. Dayco Belt 5080485 (Not Shown) (1) |
| 9. 10mm 1.5 Nut (2) | 16. Clutch Pump Assembly (<i>Sold Separately</i>) |