



FR SERIES PTO

FOR THE FORD F-SUPER DUTY
TORQSHIFT® AUTOMATIC TRANSMISSION

The Ford TorqShift® 5 speed automatic transmission for truck applications is available with a PTO opening on the left side. The Muncie FR Series PTO is exclusively designed for the TorqShift® automatic to provide maximum PTO output.

The Muncie FR Series PTO is available in several output configurations and there are versions for the 4x2 and 4x4 vehicles, F250 thru F550.

FR Series PTOs are based on proven design concepts and were developed in cooperation with Ford Motor Co. engineering product teams.

FR SERIES PTO FEATURES:

- High Capacity Bearings
- Robust Wet Clutch Pack
- Weight Saving Aluminum Housing
- Output Speed = 126% of engine speed
- Remote Driveline Output for 4x2 application – 1-1/4" round
- Highest Torque Available – Output Rating up to 190 Ft-Lbs
- Direct Hydraulic Pump Mounts for SAE "A" (5/8" - 9T), SAE (3/4" - 11T)
- Simple Wiring Harness Connects with Ford's Electronic System for Diesel or Gas Throttle Control
- Sealed Connectors for Trouble-Free, Water-Tight Connections
- PTO version for 4x4 (FR67 can be used on 4x2)
- Pump flows to 17 GPM @ 1200 engine speed (limited pump sizes on 4x4 applications)



FR63 DIMENSIONS

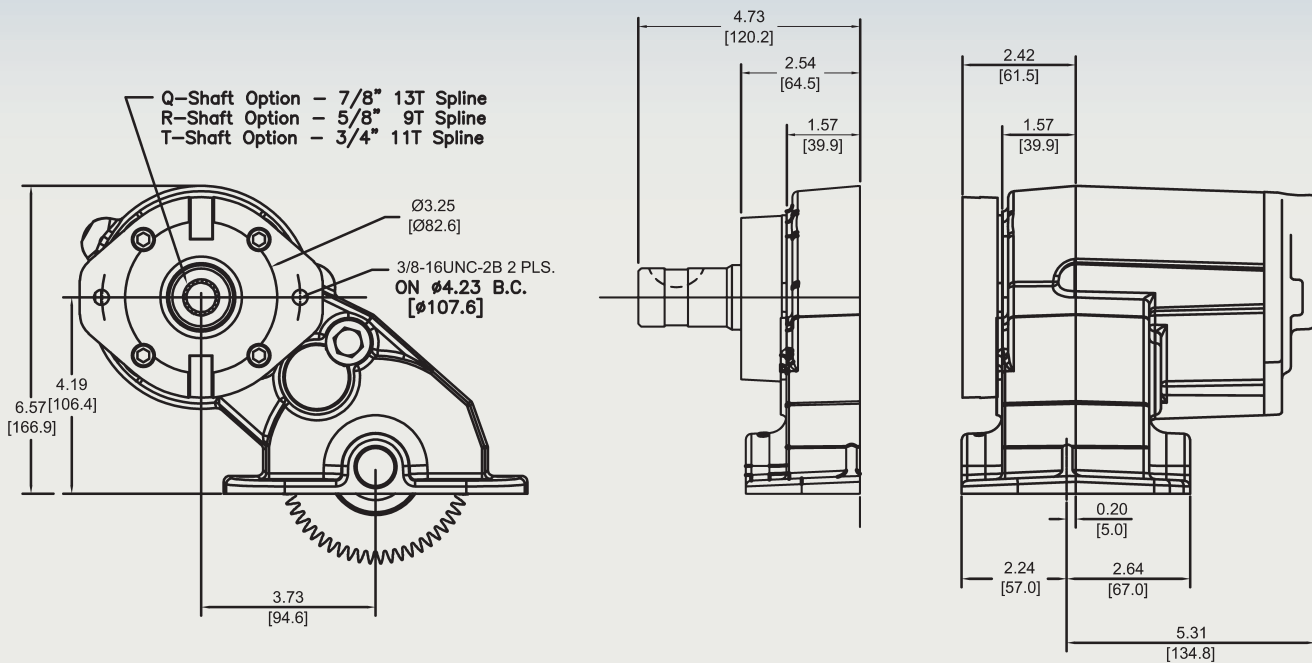

FR67 DIMENSIONS

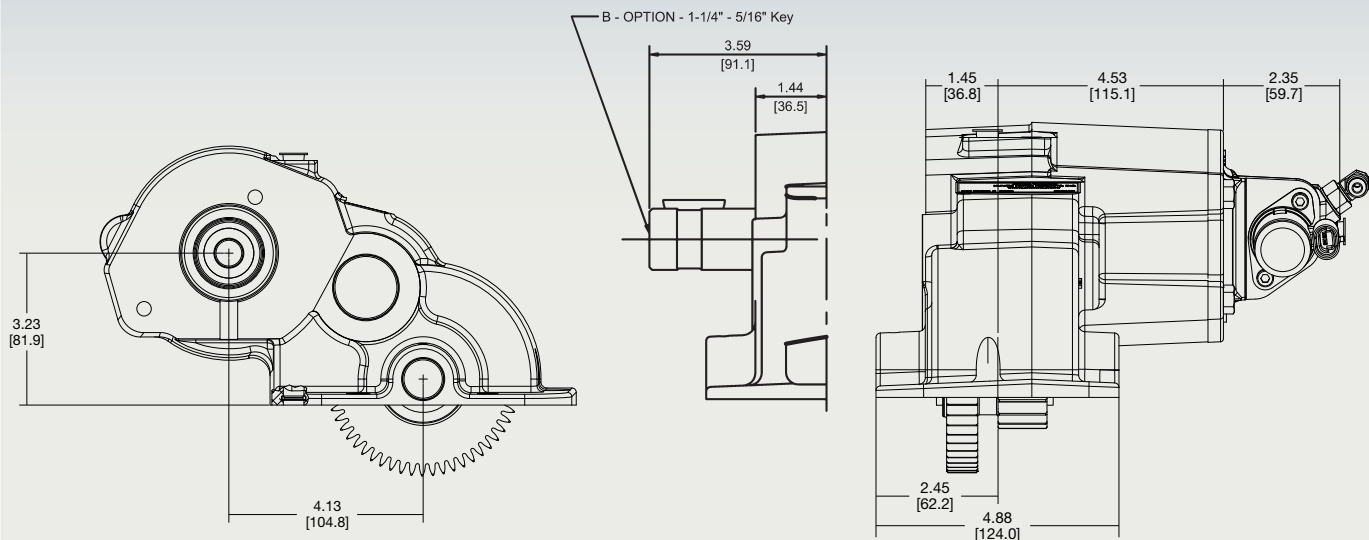

- Built-in solenoid valve for a compact installation without need for additional mounting brackets.
- Single line connection means fewer hoses & plumbing for a quicker and easier installation.



MP05-02 (Rev. 1-11) Printed in the U.S.A.
 ©Muncie Power Products, Inc. 2011

Muncie Power Products, Inc. Member of the Interpump Hydraulics Group
 General Offices and Distribution Center • P.O. Box 548 • Muncie, IN 47308-0548
 (765) 284-7721 • FAX (765) 284-6991 • E-mail info@munciepower.com
 Web site <http://www.munciepower.com>

Drive Products, Exclusive Agents for Canada, ISO Certified by an Accredited Registrar