



CS6 & CS8

CLUTCH SHIFT PTO

CLUTCH SHIFT PTO

YOU CAN PROVIDE POWERSHIFTED PTO POWER FOR AUTOMATIC AND STANDARD TRANSMISSIONS WITH MUNCIIE'S CS6 & CS8 PTO.

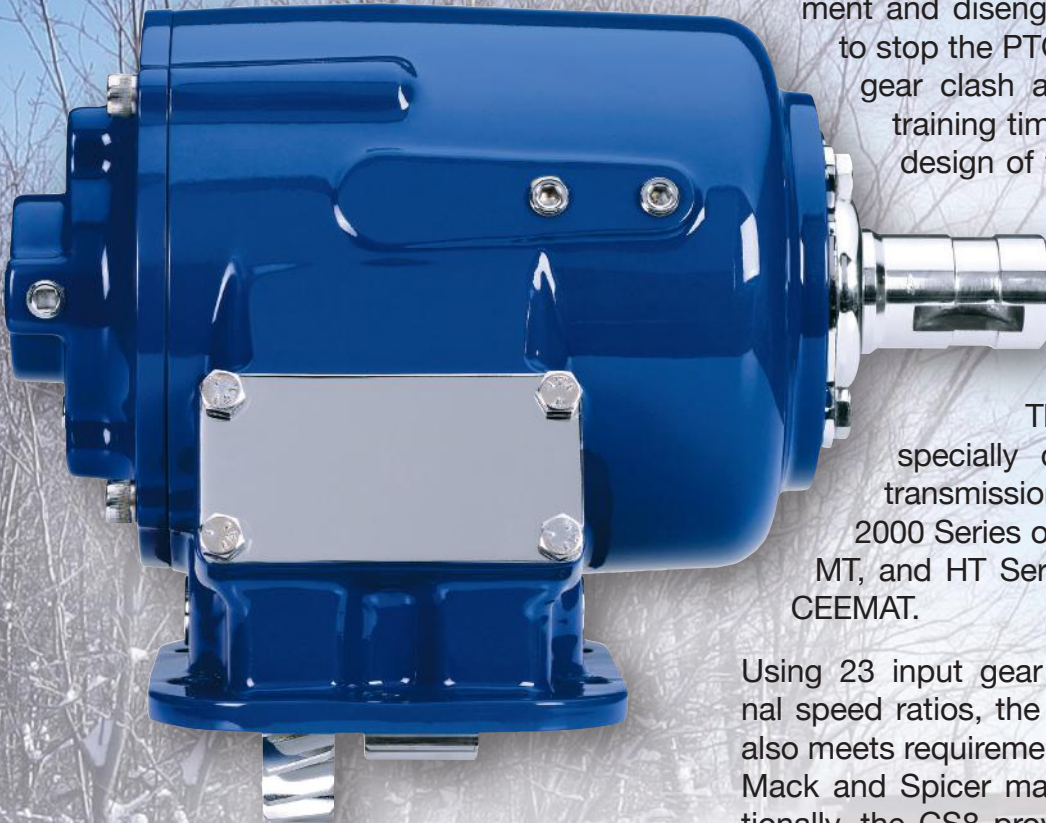

The internal wet clutch permits easy engagement and disengagement without the need to stop the PTO drive gear. This prevents gear clash and reduces new operator training time. The enhanced capacity design of the CS6 and CS8 includes many features of the popular Muncie CS10 and CS20 PTOs made for Allison World Transmissions.

The CS6 and CS8 PTO is specially designed to fit automatic transmissions like the Allison 1000 or 2000 Series or Aisin and older Allison AT, MT, and HT Series, JATCO, and the Fuller CEEMAT.

Using 23 input gear designs and seven internal speed ratios, the CS6 and CS8 Series PTO also meets requirements for many popular Fuller, Mack and Spicer manual transmissions. Additionally, the CS8 provides convenient mounting on 8-bolt openings without special adapters. As an option, the CS Series can be changed to the CB Series which changes the drag brake to a clutch-actuated brake. This brake ensures that the output shaft is automatically stopped and does not require any adjustments. Perfect for low-torque LP Gas or delivery pump applications.

The CS Series is available with standard 1-1/4 Rd. output shaft, or with several direct mount hydraulic flange and shaft options, all with the convenience of rotatable flanges that can be easily repositioned to gain pump clearance or to access hydraulic ports. The CS6 and CS8 Series PTOs include the patented internal drag brake designed to eliminate unwanted shaft rotation.

FEATURES

- **High Strength Ductile Iron Housings**
- **Torque Ratings From 275-350 Lb.ft.**
- **Patented Internal Drag Brake**
- **Optional Automatic Clutch Brake (CB series)**
- **Three Ways to Shift: Hydraulic, Air, Electric/Air**
- **Allows for Overspeed Protection (Optional SPD-1000A)**



MODEL NUMBER CONSTRUCTION

CS 6S - M65 07 - E 1 B X

PTO TYPE

Clutch Shift (Standard Drag Brake) CS
Clutch Shift (Optional Shaft Brake) CB

MOUNTING

SAE 6-Bolt Std. Mtg. -6S
SAE 6-Bolt Non-Std. Mtg. -6D
SAE 6-Bolt Non-Std. Mtg. Deep -6N
SAE 6-Bolt Std. Mtg. Metric -6M
SAE 6-Bolt Non-Std. Mtg. Metric -6C
SAE 8-Bolt Std. Mtg. -8S
SAE 8-Bolt Std. Mtg. Metric -8M
SAE 8-Bolt Non-Std. Mtg. -8D
SAE 8-Bolt Non-Std. Mtg. Metric -8S

TRANSMISSION (Input Gear Options)

Aisin	-I84	Fuller	-F84
Aisin	-I85	Fuller	-F85
Allison	-A68	Fuller	-F86
Allison	-A69	Mack	-M65
Clark/Fuller	-C61	Mercedes	-M83
Clark/Fuller	-C70	Spicer	-S73
Fuller	-F10	Spicer	-S71
Fuller	-F11	Spicer	-S60
Fuller	-F61	Spicer	-S70
Fuller	-F63	Universal	-S68
Fuller	-F66	Universal	-U60
Fuller	-F70	Universal	-U68

SPEED RATIO*

03 - 0.33:1	07 - 0.70:1
04 - 0.44:1	09 - 0.87:1
05 - 0.47:1	12 - 1.15:1
06 - 0.56:1	14 - 1.44:1 (8-bolt only)

* Not all combinations are available for input gear options. Refer to application catalog or service parts list for additional information.

SPECIAL FEATURES

X - None
C - Pulse Generator / Press. Lube / SPD1000A
D - Pulse Generator & SPD1000A
P - Pressure Lube
R - Pulse Generator / No Prew S - Pulse Generator / Pressure Lube

OUTPUT TYPE

B - 1-1/4 Round 5/16 KW
C - 1410 Companion Flange
G - Special
K - SAE "B" 2 & 4-bolt
L - Low-Box Only
Q - SAE "A" 2-bolt
P - SAE "B-B" 2 & 4-bolt
S - SAE "B" 2-bolt
Z - SAE "B" 2 & 4-bolt C Shaft
R - SAE "A" 2-bolt
I - DIN 5462
6 - SAE "B" 2-bolt
2 - DIN Companion Flange
T - SAE "A" 2-bolt

ASSEMBLY ARRANGEMENT

1, 2, 3, or 4 (See Below)

SHIFTER TYPE

A - Manual Air
E - Electric/Air 12v
F - Electric/Air 24v
H - Electric/Hyd 12v
J - Electric/Hyd 24v

DIMENSIONS

STANDARD 1-1/4 ROUND KEYED SHAFT ("B" OPTION) CS6/8 OR CB6/8 MODELS

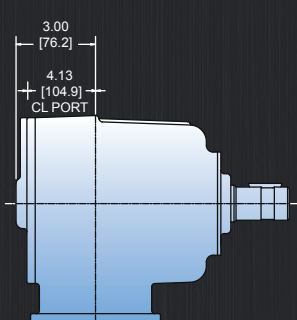
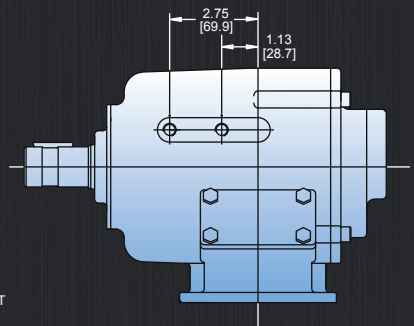
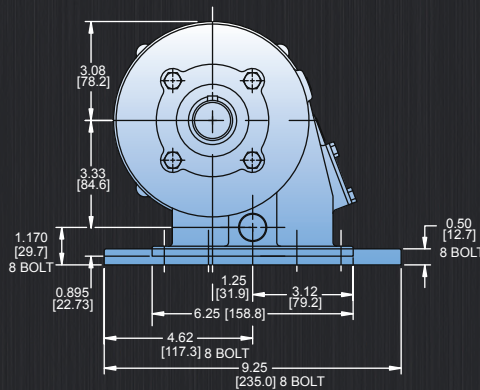
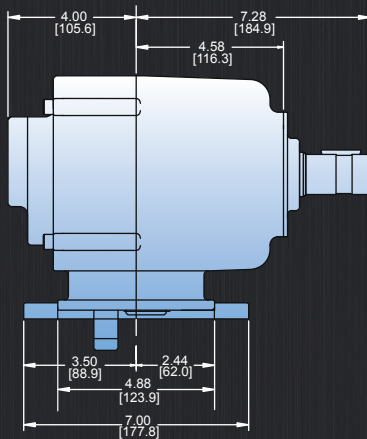

CS6G HOUSING OPTION
"B" or "K" Shaft Only.
No Drake Brake

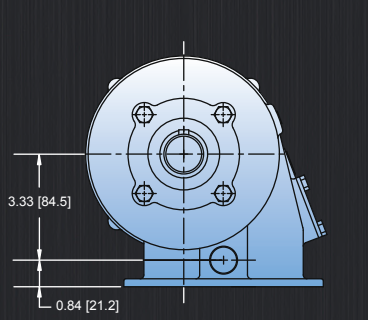

CS6N HOUSING DIMENSION

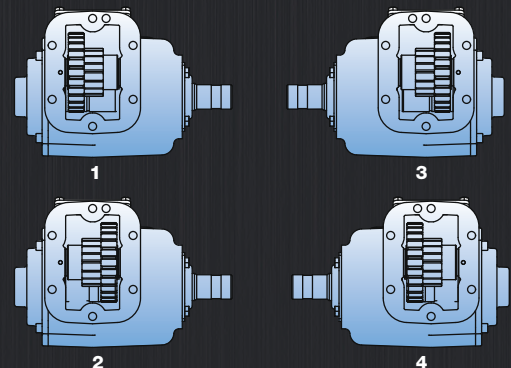

ARRANGEMENT



CLUTCHSHIFT OUTPUT SHAFT OPTIONS

CS6/CS8 OPTIONS ONLY UNLESS SPECIFIED

G OPTION SPECIAL 7/8-13 Spline

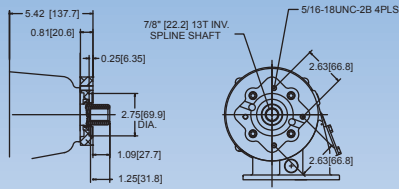

Q OPTION SAE "A" 2 Bolt 7/8-13 Spline

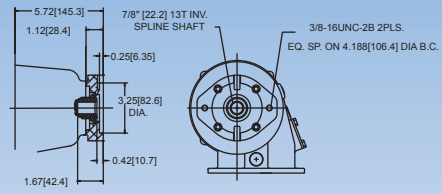

K OPTION SAE "B" 2&4 Bolt 7/8-13 Spline CB6/8 Optional

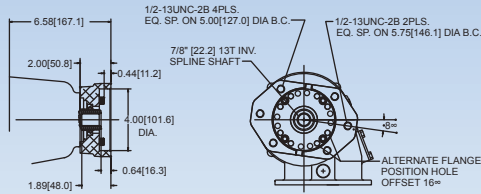

S OPTION SAE "B" 2 Bolt 7/8-13 Spline

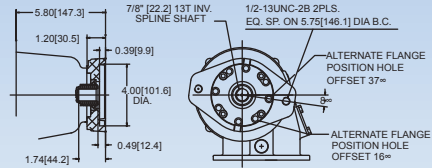

P OPTION SAE "B-B" 2&4 Bolt 1"-15 Spline

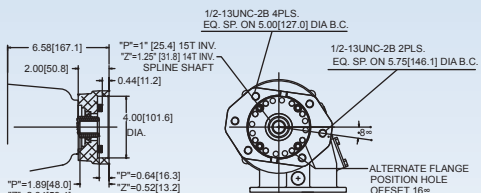

Z OPTION Non-Std. 2&4 Bolt 1-1/4"-14 Spline



6 OPTION SAE "B" 2 Bolt 7/8-13 Spline

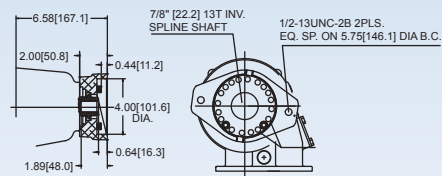

C OPTION 1410 SERIES Comp. Flange

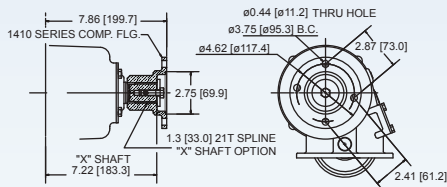

R OPTION SAE "A" 2 Bolt 5/8-9 Spline

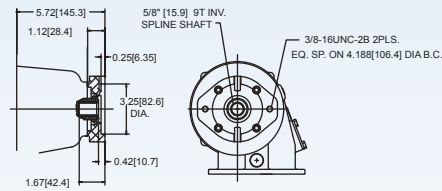

2 OPTION DIN 100 Comp. Flange

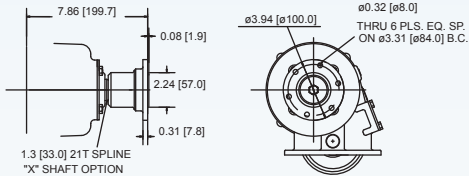

T OPTION SAE "A" 2 Bolt 3/4-11 Spline

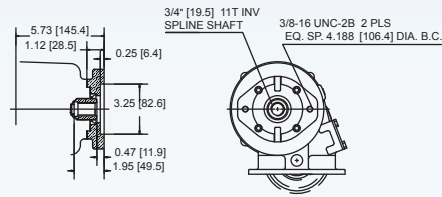

SYSTEM PROTECTION DEVICE

Muncie SPD-1000A — (optional)



Work trucks are often used in situations which require the operator to focus on the job rather than the equipment. This is when a high percentage of equipment damage occurs. Cylinders can be over-pressurized, cylinder rods can bend, PTOs and pumps can exceed the maximum speeds, and device can be accidentally activated or activated without proper safety procedures in place. These situations can be prevented.

The Muncie SPD-1000A is NOT JUST ANOTHER SPEED SWITCH! In addition to the ability to monitor engine speeds, it can also be activated by vehicle speed, temperature or pressure signals, position indicators, brake interlock signals, and many other critical indicators.



CB6/8 SERIES

CLUTCH BRAKE



CB Series clutch brakes are built using the same technology that had provided swift and sure engagement of the PTO clutch. A second, multi-disk assembly is built into the PTO output shaft to provide a safe means to eliminate shaft rotation. When the PTO clutch engages, the clutch brake disengages. When the clutch disengages, the clutch brake engages. NO additional connections are required. The internal, multi-disk brake produces no harmful debris as might be generated with a metal to metal design.

The Muncie CB Series PTO has been tested for thousands of shift cycles in the test laboratory as well as on vehicles and will provide for reliable service with no need for adjustment.

CSGB200-125

ULTRA LOW SPEED GEARBOX

The CSGB200-125 gearbox lowers the output shaft speed of up to half the typical output shaft speed from the CS6 PTO. It is specifically designed to fit and operate on the Allison 1000 or 2000 Series transmissions.

IDEAL FOR DRIVING APPLICATIONS SUCH AS:
WATER • PROPANE • FUEL OIL PUMPS

Available with an 1-1/4" round, keyed output shaft that rotates opposite the engine's crankshaft.

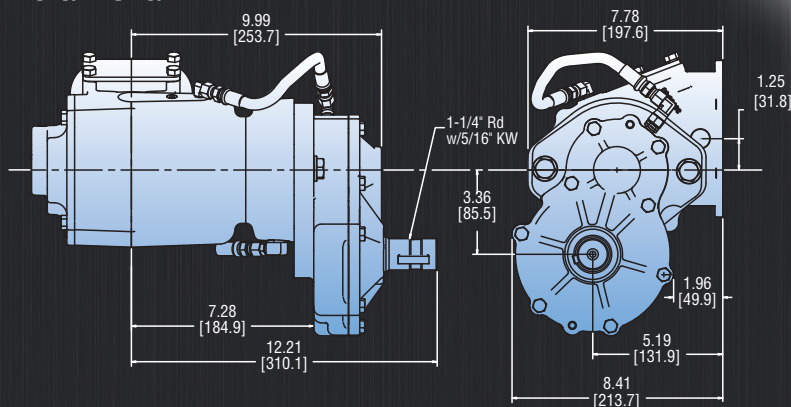

ONE YEAR POWER TAKE-OFF WARRANTY

The Muncie Power Take-Off is warranted to be free of defects in material or workmanship and to meet Muncie's standard written specifications at the time of sale. Muncie's obligation and liability under this warranty is expressly limited to repairing or replacing, at Muncie's option, within one year after date of original installation any defective part or parts or any product not meeting the specifications.

THIS WARRANTY IS IN LIEU OF ALL OTHER WARRANTIES, EXPRESSED OR IMPLIED. MUNCIE MAKES NO WARRANTY OF MERCHANTABILITY OR OF FITNESS FOR ANY PARTICULAR PURPOSE. MUNCIE'S OBLIGATION UNDER THIS WARRANTY SHALL NOT INCLUDE ANY TRANSPORTATION CHARGES OR COSTS OF INSTALLATION OR ANY LIABILITY FOR DIRECT, INDIRECT, SPECIAL, INCIDENTAL, OR CONSEQUENTIAL DAMAGES OR DELAY. THE REMEDIES SET FORTH HEREIN ARE EXCLUSIVE, AND MUNCIE'S LIABILITY WITH RESPECT TO ANY CONTRACT OR SALE OR ANYTHING DONE IN CONNECTION THEREWITH, WHETHER IN CONTRACT, IN TORT, UNDER ANY WARRANTY, OR OTHERWISE, SHALL NOT, EXCEPT AS EXPRESSLY PROVIDED HEREIN, EXCEED THE PRICE OF THE PRODUCT OR PART ON WHICH SUCH LIABILITY IS BASED.

If requested by Muncie, products or parts for which a warranty claim is made are to be returned transportation prepaid to a Muncie Service Center. Any installation or use not in accordance with catalog or package instructions, other improper use, operation beyond capacity, substitution of parts not approved by Muncie, use with equipment other than the equipment on which the Power Take-Off is first installed, or alteration or repair made to the Power Take-Off other than at a Muncie Service Center, shall void this warranty. No employee or representative of Muncie is authorized to change this warranty in any way or to grant any other warranty.

Distributed By:



**Muncie[®]
Power
Products**