



ALPHA SERIES

MUNCIE'S PTO FOR DODGE CHASSIS CABS

**ALPHA MAKES INSTALLATION EASY- PROVIDING
MAXIMUM CLEARANCE USING DURABLE
PROVEN COMPONENTS.**

- **COMPACT SIZE**
- **INTEGRAL SHIFTER**
- **ELECTRIC/HYDRAULIC OR
CABLE OPTIONS**
- **MULTIPLE RATIOS AND
OUTPUT OPTIONS**
- **PUMP MOUNTS TO FRONT
OR REAR**
- **INTERNAL COMPONENTS
COMMON TO TG SERIES**



CONTACT MUNCIE FOR ADDITIONAL INFORMATION OR TO PLACE YOUR ORDER.

ALPHA SERIES

MODEL NUMBER CONSTRUCTION

A 1 6M - D94 13 - C 4 T X

MODEL

ALPHA - A

DESIGN NUMBER

1

MOUNTING

6-BOLT EXTRA DEEP MOUNT - 6M

INPUT GEAR

MERCEDES/DODGE G56-6 - D94

RATIO

07 - .72:1 12 - 1.17:1
 08 - .89:1 13 - 1.28:1
 09 - .92:1 15 - 1.50:1
 18 - 1.72:1

SPECIAL FEATURES

X - NONE

OUTPUT TYPE

B - 1 1/4 RD (4X2 Only)
 K - SAE B 2&4 BOLT (4X2 Only)
 Q - SAE A 7/8 13T **
 R - SAE A 5/8 9T **
 S - SAE B 2 Bolt (4X4 "1" Arrng Only)
 T - SAE A 3/4 11T **

** (4X4 "4" Arrng w/ Pump to Rear
 OR "1" Arrng w/ Pump to Front)

ASSEMBLY ARRANGEMENT

1 - 4X4 PUMP TO FRONT
 4 - 4X4 PUMP TO REAR

SHIFT TYPE

A - AIR
 C - CABLE
 E - ELECTRIC/AIR
 T - E-HYDRA (call for availability)

DIMENSIONS

4-Assembly Arrangement with Muncie PF Series pump mounted to rear of PTO. Pump rotation - CCW

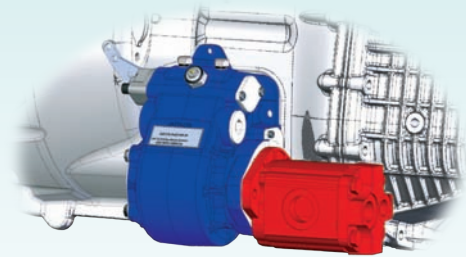

"T" Option - SAE A 2-Bolt
 3.25" Pilot - 3/4" 11T Spline
 3/8-16UNC-2B on 4.18" B.C.

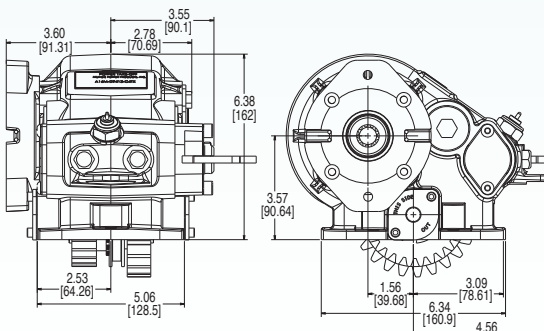

1-Assembly Arrangement with Muncie PKS Series pump mounted to front of PTO. Pump rotation - CW

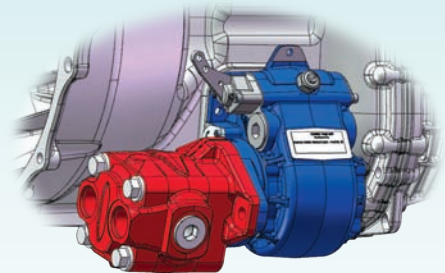

"S" Option - SAE B 2-Bolt
 4" Pilot - 7/8" 13T Spline
 1/2-13UNC-2B on 5.75" B.C.

