



Z SERIES

Hydraulic Pump/Motor Product Group

Replacement parts for Industry common pump series.

Pump assemblies custom built to your replacement or new installation requirements.

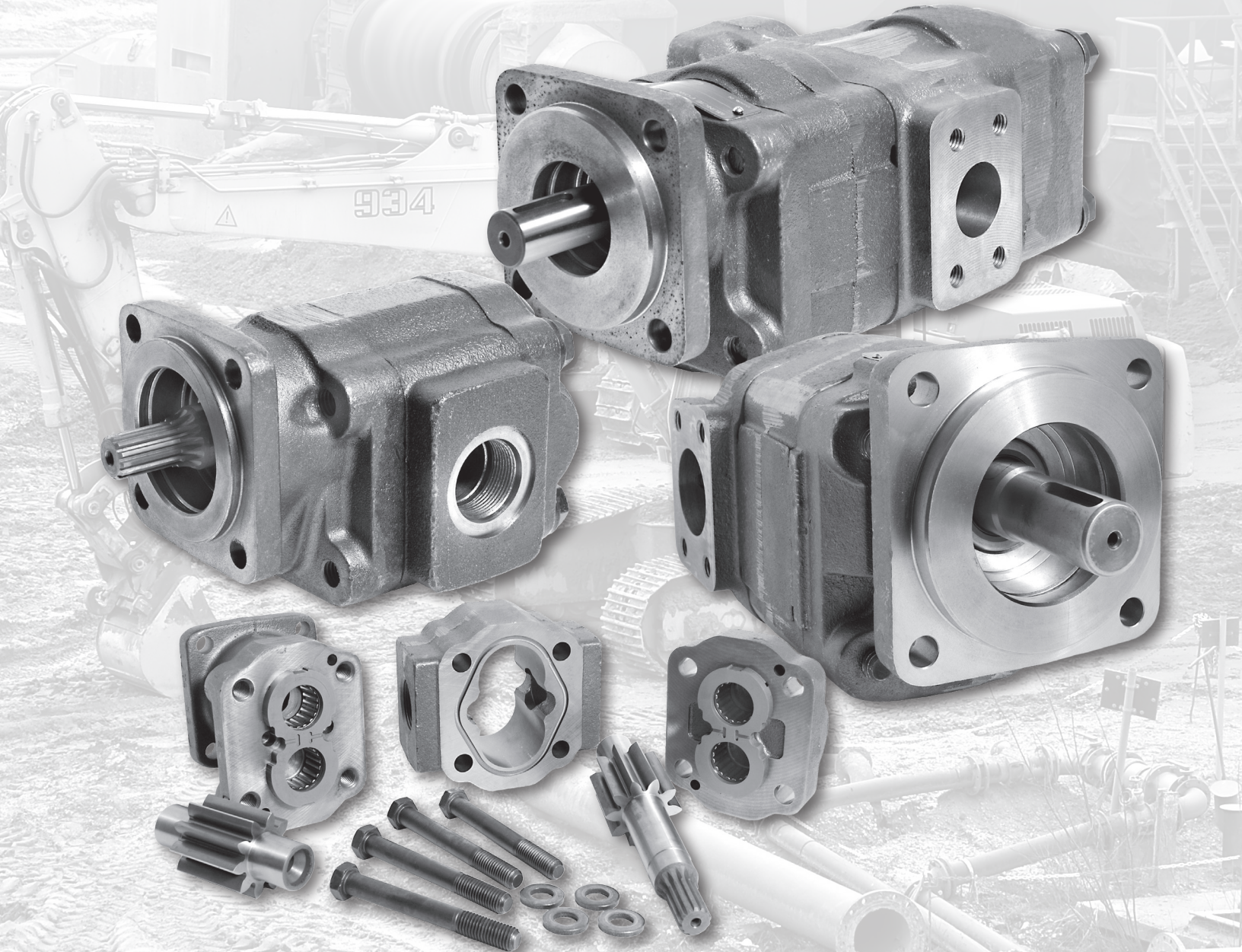

FOR MOBILE APPLICATIONS

- Construction
- Mining
- Forestry
- Truck
- Agriculture
- Marine
- Material Handling

Z SERIES

Hydraulic Pump/Motor Product Group

PUMP/MOTOR PRODUCT

- Output flows ranging from 4-53 GPM @ 1,000 RPM
- All cast iron housing construction
- High pressure capabilities
- High speed capabilities
- Numerous shaft and flange options
- SAE, NPT, or split flange porting

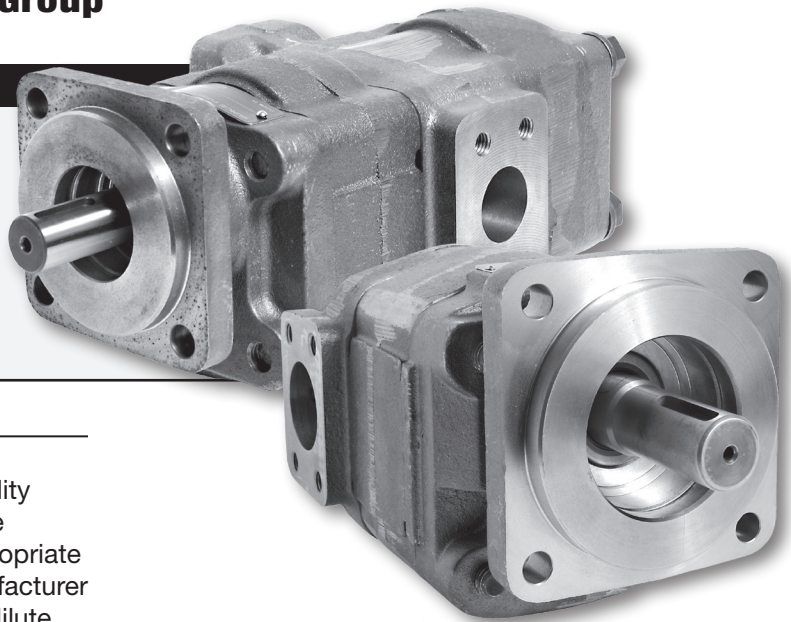

OIL RECOMMENDATIONS

Muncie does not promote specific manufacturers' brands of oil but does recommend the use of quality petroleum based hydraulic fluids. Different climate temperatures require that the oil viscosity be appropriate for the operating conditions. Consult the oil manufacturer for your exact application needs. (**NOTE:** Never dilute the hydraulic fluid for cold weather operation, including but not limited to diesel fuel, kerosene, etc.)

- **Oil Viscosity:** 60-1,000 SUS (10.5-216 cST) for continuous operation. Viscosity should not exceed 7,500 SUS (1,600 cST) maximum at startup.
- **Special Fluids:** Biodegradable and water glycol type fluids are ok for use with bushing design only—not roller bearing designed product.

INLET / OUTLET CONDITION

Vacuum: Inlet vacuum should not exceed 5 in.Hg. maximum across all operating RPM's and temperature conditions. **Note:** An undersized inlet port size could have maximum RPM limitations and an oversized outlet port size could have maximum pressure limitations.

OPERATING TEMPERATURE

Proper control of the system operating temperatures is critical for long life of not only the pump but also the other components in the hydraulic system. Optimum operating temperatures should be between 100–140° F (37.8–60° C), Continuous - 180° F (82° C) max., Intermittent - 200° F. (93° C)

HOSE SIZING

Hydraulic hose must be properly sized based on the oil velocity in feet per second (FPS) and of the appropriate type (SAE rating) for the specified rate of flow and pressure.

- **Inlet Hose:** 2–4 FPS, SAE 1004 Type
- **Pressure Hose:** 7–15 FPS, SAE 100R2 Type minimum or as needed for the application.
- **Return Hose:** 4–8 FPS, SAE Type 100R1 or as needed for the application.

FILTRATION

Properly applied filtration and maintenance is critical for long life of not only the pump but also the other components in the hydraulic system.

- **Suction Strainers:** Useful in catching large objects, never size smaller than 100, always include a bypass of 3 PSI (.2 Bar).
- **Pressure Filter:** Pressure filters are typically not required for gear pump applications but are available if desired.
- **Return Filters:** Return filters are always recommended with a minimum 10 micron nominal rating. Some applications require better filtration with an absolute rating and even 3 or 6 micron media.

STARTUP OF A NEW OR REBUILT PUMP

Before startup of a new or rebuilt pump the installer should always:

- Properly install the pump and all other necessary components
- Fill the pump ports with clean oil.
- Back off the main relief valve or have complete confidence of its proper set point.
- Connect all lines for proper operation.
- Engage the pump and allow to run under a no load condition for 2 minutes at idle.
- If ok, increase to normal operating RPM & repeat, if still ok, reset (if needed) the main relief valve to its proper setting while at operating RPM.

ROLLER BEARING DESIGN

Z Series (Ref. P/M Series): Z*10 (*20), Z*13 (*30), Z*16 (*31)^A

SPECIFICATION (GEAR WIDTH)	0.5	0.75	1	1.25	1.5	1.75	2	-	-	-	-
Housing Width (in.)	1.25	1.5	1.75	2	2.25	2.5	2.75	-	-	-	-
Displacement cu.in (cc.)	0.99 (16.1)	1.48 (24.2)	1.97 (32.3)	2.46 (40.4)	2.96 (48.4)	3.45 (56.5)	3.94 (64.6)	-	-	-	-
GPMT (LPM) @ 1,000 RPM	4.3 (16.1)	6.4 (24.2)	8.5 (32.3)	10.7 (40.4)	12.8 (48.4)	14.9 (56.5)	17.1 (64.6)	-	-	-	-
Min. RPM	900	900	900	900	900	900	900	-	-	-	-
Max. RPM	2,400	2,400	2,400	2,400	2,400	2,400	2,400	-	-	-	-
Max. Pressure PSI (BAR)-Z*13	2,500 (172)	2,500 (172)	2,500 (172)	2,500 (172)	2,500 (172)	2,250 (155)	2,250 (155)	-	-	-	-
Max. Pressure PSI (BAR)-Z*10, 16	3,000 (207)	3,000 (207)	3,000 (207)	3,000 (207)	3,000 (207)	2,500 (172)	2,500 (172)	-	-	-	-
Approx. Wt. lbs.(Kg.) - Single	31 (14)	32 (14.5)	33 (15)	34 (15.5)	35 (16)	36 (16.5)	37 (17)	-	-	-	-
Approx. Wt. lbs.(Kg.) - Tandem ^B	25 (11)	26 (11.5)	27 (12)	28 (12.5)	29 (13)	31 (14)	32 (14.5)	-	-	-	-
MOTOR DATA: Motor Torque and HP values shown below are based on 1,000 RPM per 1,000 PSI, no efficiency values are in the calculations for GPMT. Maximum pressure ratings are the same as the pumps shown above.											
Motor Input GPMT @ 1,000 RPM	4.3	6.4	8.5	10.7	12.8	14.9	17.1	-	-	-	-
Motor/Output Torq. in.lbs. @ 1,000 RPM	158.1	235.3	312.5	393.4	470.7	547.9	628.8	-	-	-	-
Motor/Output HP Per 1,000 PSI	2.5	3.7	5.0	6.2	7.5	8.7	10.0	-	-	-	-
Motor Min. RPM	900	900	900	900	900	900	900	-	-	-	-
Motor Max. RPM	2,400	2,400	2,400	2,400	2,400	2,400	2,400	-	-	-	-

SHAFT OPTIONS:

- SAE "B" 13T Spline, 0.88" Dia.
- SAE "B" Keyed .88" Dia., 0.25" Key
- SAE "BB" Keyed 1.00" Dia., 0.25" Key
- SAE "BB" 15T Spline, 1.00" Dia.
- 6T Spline 1.00" Dia.

- Keyed Shaft 0.75 Dia., .19" Key
- Clutch Pump Shaft, Tapered & Keyed, 1:4 Taper
- SAE "A" 9T Spline ¾" Dia.
- SAE "C" 14T Spline 1.25" Dia.

MOUNTING FLANGES:

- SAE "A" 2-Bolt, Pilot Dia. 3.3"
- SAE "B" 2-, 4-, 2/4-Bolt, Pilot Dia. 4"
- Pad Mount
- 6-Bolt Flange - 3.3" Dia. Bolt Circle Pilot Dia. 2.6"

DIMENSIONS IN.(MM) - SINGLE

- Dim A: 5.38 (136.5)
- Dim B: 5.44 + GW (138.1 + GW)
- Dim C: 5.44 (138.1)
- Dim F: 3.12 (79.2)

DIMENSIONS IN.(MM) - TANDEM

- Dim A: 5.38 (136.5)
- Dim B: 8.69 + TGW (220.7 + TGW)
- Dim C: 5.44 (138.1)
- Dim BC: 2.50 (63.5)

BOLT DIAMETER

- Z10: ¼"-12 UNC
- Z13&16: ⅜"-11 UNC

PORTING:

- SAE/ODT, Split Flange

THRUST PLATE THICKNESS

- Each plate: 0.375in. (2 Req.)

Z Series (Ref. P/M Series): Z*19 (*50), Z*22 (*51)^A

SPECIFICATIONS (GEAR WIDTH)	0.5	0.75	1	1.25	1.5	1.75	2	2.25	2.5	-	-
Housing Width (in.)	1.25	1.5	1.75	2	2.25	2.5	2.75	3.0	3.25	-	-
Displacement cu.in (cc.)	1.28 (20.9)	1.91 (31.3)	2.55 (41.8)	3.19 (52.2)	3.83 (62.7)	4.46 (73.1)	5.10 (83.6)	5.74 (94.0)	6.38 (104.5)	-	-
GPMT (LPM) @ 1,000 RPM	5.5 (20.9)	8.3 (31.3)	11 (41.8)	13.8 (52.2)	16.6 (62.7)	19.3 (73.1)	22.1 (83.6)	24.8 (94.0)	27.6 (104.5)	-	-
Min. RPM	900	900	900	900	900	900	900	900	900	-	-
Max. RPM	2,400	2,400	2,400	2,400	2,400	2,400	2,400	2,400	2,400	-	-
Max. Pressure PSI (BAR)-Z*19	2,500 (172)	2,500 (172)	2,500 (172)	2,500 (172)	2,500 (172)	2,000 (138)	2,000 (138)	2,000 (138)	2,000 (138)	-	-
Max. Pressure PSI (BAR)-Z*22	3,000 (207)	3,000 (207)	3,000 (207)	3,000 (207)	3,000 (207)	3,000 (207)	2,500 (172)	2,500 (172)	2,500 (172)	-	-
Approx. Wt. lbs.(Kg.) - Single	34 (16)	35.5 (16.5)	37 (17)	38.5 (17.5)	40 (18)	41.5 (19)	43 (19.5)	48.5 (22)	50 (22.5)	-	-
Approx. Wt. lbs.(Kg.) - Tandem ^B	28 (13)	29.5 (13.5)	31 (14)	32.5 (15)	34 (15.5)	35.5 (16)	37 (17)	42.5 (19)	44 (20)	-	-
MOTOR DATA: Motor Torque and HP values shown below are based on 1,000 RPM per 1,000 PSI, no efficiency values are in the calculations for GPMT. Maximum pressure ratings are the same as the pumps shown above.											
Motor input GPMT @ 1,000 RPM	5.5	8.3	11	13.8	16.6	19.3	22.1	24.8	27.6	-	-
Motor/Output Torq. in.lbs. @ 1,000 RPM	202.2	305.2	404.5	507.4	610.4	709.7	812.6	911.9	1014.9	-	-
Motor/Output HP @ 1,000 PSI	3.2	4.8	6.4	8.1	9.7	11.3	12.9	14.5	16.1	-	-
Motor Min. RPM	900	900	900	900	900	900	900	900	900	-	-
Motor Max. RPM	2,400	2,400	2,400	2,400	2,400	2,400	2,400	2,400	2,400	-	-

SHAFT OPTIONS:

- SAE "B" 13T Spline, 0.88" Dia.
- SAE "BB" 15T Spline, 1.00" Dia.
- SAE "BB" Keyed 1.00" Dia., ¼" Key.
- SAE "C" 14T Spline 1.25" Dia.

- SAE "C" Keyed 1.25" Dia. ⅜" Key
- SAE "B" 13T Spline ¾" Dia. Short
- SAE "C" 14T Spline 1.25" Dia. Short

MOUNTING FLANGES:

- SAE "B" 2-, 4-, 2/4-Bolt, Pilot Dia. 4"
- SAE "C" 2-, 4-, 2/4-Bolt, Pilot Dia. 5"
- 4-Bolt Pad Mount

DIMENSIONS IN.(MM) - SINGLE

- Dim A: 6.00 (152.4)
- Dim B: 5.88 + GW (149.2 + GW)
- Dim C: 5.44 (138.1)
- Dim F: 3.56(90.4)

DIMENSIONS IN.(MM) - TANDEM

- Dim A: 6.00 (152.4)
- Dim B: 9.50 + TGW (241.3 + TGW)
- Dim C: 5.44 (138.1)
- Dim BC: 2.88 (73.0)

BOLT DIAMETER

- ⅜"-11 UNC

PORTING:

- SAE/ODT, Split Flange

THRUST PLATE THICKNESS

- Each plate: 0.375in. (2 Req.)

Z Series (Ref. P/M Series): Z*26 (*75), Z*28 (*76)^A

SPECIFICATIONS (GEAR WIDTH)	-	0.75	1	1.25	1.5	1.75	2	2.25	2.5	2.75	3
Housing Width (in.)	-	1.75	2	2.25	2.5	2.75	3	3.25	3.5	3.75	4
Displacement cu.in (cc.)	-	3.08 (50.4)	4.10 (67.2)	5.13 (84.0)	6.15 (100.8)	7.18 (117.6)	8.20 (134.4)	9.23 (151.2)	10.25 (168.0)	11.28 (184.8)	12.30 (201.6)
GPMT (LPM) @ 1,000 RPM	-	13.3 (50.4)	17.7 (67.2)	22.2 (84.0)	26.6 (100.8)	31.1 (117.6)	35.5 (134.4)	40 (151.2)	44.4 (168.0)	48.8 (184.8)	53.2 (201.6)
Min. RPM	-	900	900	900	900	900	900	900	900	900	900
Max. RPM	-	2,400	2,400	2,400	2,400	2,400	2,400	2,400	2,400	2,400	2,400
Max. Pressure PSI (BAR)-Z*26	-	2,500 (172)	2,500 (172)	2,500 (172)	2,500 (172)	2,500 (172)	2,500 (172)	2,250 (155)	2,250 (155)	2,000 (138)	2,000 (138)
Max. Pressure PSI (BAR)-Z*28	-	3,000 (207)	3,000 (207)	3,000 (207)	3,000 (207)	3,000 (207)	2,500 (172)	2,500 (172)	2,500 (172)	2,000 (138)	2,000 (138)
Approx. Wt. lbs.(Kg.) - Single	-	70 (32)	72 (33)	75 (34)	77 (35)	80 (36)	82 (37)	85 (39)	87 (40)	90 (41)	92 (42)
Approx. Wt. lbs.(Kg.) - Tandem ^B	-	57 (26)	59 (27)	62 (28)	64 (29)	67 (31)	69 (32)	72 (33)	74 (34)	77 (35)	79 (36)
MOTOR DATA: Motor Torque and HP values shown below are based on 1,000 RPM per 1,000 PSI, no efficiency values are in the calculations for GPMT. Maximum pressure ratings are the same as the pumps shown above.											
Motor input GPMT @ 1,000 RPM	-	13.3	17.7	22.2	26.6	31.1	35.5	40	44.4	48.8	53.2
Motor/Output Torq. in.lbs. @ 1,000 RPM	-	489.0	650.8	816.3	978.1	1143.5	1305.3	1470.8	1632.6	1794.4	1956.2
Motor/Output HP - Minimum	-	7.8	10.3	13.0	15.5	18.1	20.7	23.3	25.9	28.5	31.0
Motor Min. RPM	-	900	900	900	900	900	900	900	900	900	900
Motor Max. RPM	-	2,400	2,400	2,400	2,400	2,400	2,400	2,400	2,400	2,400	2,400

SHAFT OPTIONS:

- SAE "C" 14T Spline, 1.3" Dia.
- SAE "C" Keyed 1.3" Dia. ⅜" Key

MOUNTING FLANGES:

- SAE "C" 2-, 4-, 2/4-Bolt, Pilot Dia. 5.00"
- SAE "B" 4-Bolt, Pilot Dia. 4.00"
- SAE "D" 4-Bolt, Pilot Dia. 6.00"

PORTING:

- SAE/ODT, Split Flange

DIMENSIONS IN.(MM) - SINGLE

- Dim A: 7.88 (200)
- Dim B: 6.75 + GW (171.5 + GW)
- Dim C: 7.75 (196.9)
- Dim G: 2.56 (65.0)

DIMENSIONS IN.(MM) - TANDEM

- Dim A: 7.88 (200)
- Dim B: 10.75 + TGW (273.1 + TGW)
- Dim C: 7.75 (196.9)
- Dim BC: 3.0 (76.2)

BOLT DIAMETER

- ⅜"-11 UNC

THRUST PLATE THICKNESS

- Each plate: 0.5 in. (2 Req.)

Notes:

A = Doweled

B = Add specified weight per each additional single section.

GW = Gear Width

TGW = Total Gear Width

BUSHING DESIGN

Z Series (Ref. P/M Series): Z*32 (*315)^A

Specifications (Gear Width)	0.375	0.5	0.625	0.75	0.875	1	1.125	1.25	1.375	1.5	1.625	1.75	1.875	2
Housing Width (in.)	.875	1	1.125	1.25	1.375	1.5	1.625	1.75	1.875	2	2.125	2.25	2.375	2.5
Displacement cu.in. (cc.)	0.47 (7.6)	0.62 (10.2)	0.78 (12.7)	0.93 (15.2)	1.09 (17.8)	1.24 (20.3)	1.40 (22.9)	1.55 (25.4)	1.71 (27.9)	1.86 (30.5)	2.02 (33.0)	2.17 (35.6)	2.33 (38.1)	2.48 (40.6)
GPMT (LPM) @ 1,000 RPM	2.0 (7.6)	2.7 (10.2)	3.4 (12.7)	4.0 (15.2)	4.7 (17.8)	5.4 (20.3)	6.1 (22.9)	6.7 (25.4)	7.4 (27.9)	8.1 (30.5)	8.7 (33.0)	9.4 (35.6)	10.1 (38.1)	10.7 (40.6)
Min. RPM	900	900	900	900	900	900	900	900	900	900	900	900	900	900
Max. RPM	3,000	3,000	3,000	3,000	3,000	3,000	3,000	3,000	3,000	3,000	3,000	3,000	3,000	3,000
Max. Pressure PSI (BAR)	3,500 (241)	3,500 (241)	3,500 (241)	3,500 (241)	3,500 (241)	3,500 (241)	3,500 (241)	3,500 (241)	3,500 (241)	3,500 (241)	3,500 (241)	3,500 (241)	3,500 (241)	3,500 (241)
Approx. Wt. lbs.(Kg.) - Single	15.5 (7.0)	16 (7.3)	16.5 (7.5)	17 (7.7)	17.5 (7.9)	18 (8.2)	18.5 (8.4)	19 (8.6)	19.5 (8.8)	20 (9.1)	20.5 (9.3)	21 (9.5)	21.5 (9.8)	22 (10)
Approx. Wt. lbs.(Kg.) - Tandem ^B	15.5 (7.0)	16 (7.3)	16.5 (7.5)	17 (7.7)	17.5 (7.9)	18 (8.2)	18.5 (8.4)	19 (8.6)	19.5 (8.8)	20 (9.1)	20.5 (9.3)	21 (9.5)	21.5 (9.8)	22 (10)
MOTOR DATA: Motor Torque and HP values shown below are based on 1,000 RPM per 1,000 PSI, no efficiency values are in the calculations for GPMT. Maximum pressure ratings are the same as the pumps shown above.														
Motor Input GPMT @ 1,000 RPM	2	2.7	3.4	4	4.7	5.4	6.1	6.7	7.4	8.1	8.7	9.4	10.1	10.7
Motor/Output Torq. in.lbs. @ 1,000 RPM	73.5	99.3	125.0	147.1	172.8	198.6	224.3	246.4	272.1	297.8	319.9	345.6	371.4	393.4
Motor/Output HP - Minimum	1.2	1.6	2.0	2.3	2.7	3.2	3.6	3.9	4.3	4.7	5.1	5.5	5.9	6.2
Motor Min. RPM	900	900	900	900	900	900	900	900	900	900	900	900	900	900
Motor Max. RPM	3,000	3,000	3,000	3,000	3,000	3,000	3,000	3,000	3,000	3,000	3,000	3,000	3,000	3,000

SHAFT OPTIONS:

- SAE "A" Keyed 0.63" Dia., 5/32" Key
- SAE "A" 9T Spline, 0.63" Dia.
- SAE "B" Keyed 0.88" Dia., 1/4" Key, Short
- SAE "B" 13T Spline, 0.88" Dia., Short
- Clutch Pump Tapered, 5/16" - 24 thd.
- #6 Woodruff Key

MOUNTING FLANGES:

- SAE "A" 2-Bolt
- Pad Mount For Clutch
- SAE "B" 2-Bolt

PORTING:

- SAE/ODT, Split Flange

DIMENSIONS IN.(MM) - SINGLE

- Dim A: 4.75 (120.7)
- Dim B: 4.27 + GW (108.5 + GW)
- Dim C: 4.0 (101.6)
- Dim D: 4.25 (108.0)
- Dim E: 4.25 (108.0)

BOLT DIAMETER

- 1/2"-13 UNC

DIMENSIONS IN.(MM) - TANDEM

- Dim A: 4.75 (120.7)
- Dim B: 7.05 + TGW (179.1 + TGW)
- Dim C: 4.0 (101.6)
- Dim D: 5.00 (127.0)
- Dim BC: 2.62 (66.5)

THRUST PLATE THICKNESS

- Each plate: 0.25 in. (2 Req.)

Z Series (Ref. P/M Series): Z*34 (*330)^A

SPECIFICATION (GEAR WIDTH)	0.5	0.75	1	1.25	1.5	1.75	2	2.25	2.5	2.75	3
Housing Width (in.)	1	1.25	1.5	1.75	2	2.25	2.5	-	-	-	-
Displacement cu.in. (cc.)	0.99 (16.1)	1.48 (24.2)	1.97 (32.3)	2.46 (40.4)	2.96 (48.4)	3.45 (56.5)	3.94 (64.6)	-	-	-	-
GPMT (LPM) @ 1,000 RPM	4.3 (16.1)	6.4 (24.2)	8.5 (32.3)	10.6 (40.4)	12.8 (48.4)	14.9 (56.5)	17.1 (64.6)	-	-	-	-
Min. RPM	900	900	900	900	900	900	900	-	-	-	-
Max. RPM	3,000	3,000	3,000	3,000	3,000	3,000	3,000	-	-	-	-
Max. Pressure PSI (BAR)	3,500 (241)	3,500 (241)	3,500 (241)	3,500 (241)	3,500 (241)	3,250 (224)	3,000 (207)	-	-	-	-
Approx. Wt. lbs.(Kg.) - Single	33.5 (15.2)	34.75 (15.8)	36 (16.3)	37.25 (16.9)	38.5 (17.5)	39.75 (18.0)	41 (18.6)	-	-	-	-
Approx. Wt. lbs.(Kg.) - Tandem ^B	33.5 (15.2)	34.75 (15.8)	36 (16.3)	37.25 (16.9)	38.5 (17.5)	39.75 (18.0)	41 (18.6)	-	-	-	-
MOTOR DATA: Motor Torque and HP values shown below are based on 1,000 RPM per 1,000 PSI, no efficiency values are in the calculations for GPMT. Maximum pressure ratings are the same as the pumps shown above.											
Motor Input GPMT @ 1,000 RPM	4.3	6.4	8.5	10.6	12.8	14.9	17.1	-	-	-	-
Motor/Output Torq. in.lbs. @ 1,000 RPM	158.1	235.3	312.5	389.8	470.7	547.9	628.8	-	-	-	-
Motor/Output HP - Minimum	2.5	3.7	5.0	6.2	7.5	8.7	10.0	-	-	-	-
Motor Min. RPM	900	900	900	900	900	900	900	-	-	-	-
Motor Max. RPM	3,000	3,000	3,000	3,000	3,000	3,000	3,000	-	-	-	-

SHAFT OPTIONS:

- SAE "B" Keyed 0.88" Dia., 1/4" Key
- SAE "BB" 13T Spline, 0.88" Dia.
- SAE "BB" 15T Spline, 1.00" Dia.
- SAE "BB" Keyed 1.00" Dia., 1/4" Key

MOUNTING FLANGES:

- SAE 2-Bolt "B"
- SAE 4-Bolt "B"

PORTING:

- SAE/ODT, Split Flange

DIMENSIONS IN.(MM) - SINGLE

- Dim A: 5.88 (149.4)
- Dim B: 6.19 + GW (157.2 + GW)
- Dim C: 4.81 (122.2)
- Dim D: 6.88 (174.8)
- Dim E: 6.88 (174.8)

BOLT DIAMETER

- 5/16"-11 UNC

DIMENSIONS IN.(MM) - TANDEM

- Dim A: 5.88 (149.4)
- Dim B: 9.88 + TGW (250.9 + TGW)
- Dim C: 4.81 (122.2)
- Dim D: 6.78 (172.2)
- Dim BC: 3.50 (88.9)

THRUST PLATE THICKNESS

- Each plate: 0.25 in. (2 Req.)

Z Series (Ref. P/M Series): Z*38 (*350)^A

SPECIFICATIONS (GEAR WIDTH)	0.5	0.75	1	1.25	1.5	1.75	2	2.25	2.5	-	-
Housing Width (in.)	1	1.25	1.5	1.75	2	2.25	2.5	2.75	3	-	-
Displacement cu.in. (cc.)	1.28 (20.9)	1.91 (31.3)	2.55 (41.8)	3.19 (52.2)	3.83 (62.7)	4.46 (73.1)	5.10 (83.6)	5.74 (94.0)	6.38 (104.5)	-	-
GPMT (LPM) @ 1,000 RPM	5.5 (20.9)	8.3 (31.3)	11.0 (41.8)	13.8 (52.2)	16.6 (62.7)	19.3 (73.1)	22.1 (83.6)	24.8 (94.0)	27.6 (104.5)	-	-
Min. RPM	900	900	900	900	900	900	900	900	900	-	-
Max. RPM	3,000	3,000	3,000	3,000	3,000	3,000	3,000	3,000	3,000	-	-
Max. Pressure PSI (BAR)	3,500 (241)	3,500 (241)	3,500 (241)	3,500 (241)	3,500 (241)	3,250 (224)	3,000 (207)	2,750 (190)	2,500 (172)	-	-
Approx. Wt. lbs.(Kg.) - Single	48 (21.7)	49.5 (22.5)	51 (23.1)	52.5 (23.8)	54 (24.5)	55.5 (25.2)	57 (25.9)	58.5 (26.5)	60 (27.2)	-	-
Approx. Wt. lbs.(Kg.) - Tandem ^B	48 (21.7)	49.5 (22.5)	51 (23.1)	52.5 (23.8)	54 (24.5)	55.5 (25.2)	57 (25.9)	58.5 (26.5)	60 (27.2)	-	-
MOTOR DATA: Motor Torque and HP values shown below are based on 1000 RPM per 1000 PSI, no efficiency values are in the calculations for GPMT. Maximum pressure ratings are the same as the pumps shown above.											
Motor Input GPMT @ 1,000 RPM	5.5	8.3	11	13.8	16.6	19.3	22.1	24.8	27.6	-	-
Motor/Output Torq. in.lbs. @ 1,000 RPM	202.2	305.2	404.5	507.4	610.4	709.7	812.6	911.9	1014.9	-	-
Motor/Output HP - Minimum	3.2	4.8	6.4	8.1	9.7	11.3	12.9	14.5	16.1	-	-
Motor Min. RPM	900	900	900	900	900	900	900	900	900	-	-
Motor Max. RPM	3,000	3,000	3,000	3,000	3,000	3,000	3,000	3,000	3,000	-	-

SHAFT OPTIONS:

- SAE "B" 13T Spline, 0.88" Dia.
- SAE "BB" Keyed 1.00" Dia., 1/4" Key
- SAE "C" 14T Spline, 1.3" Dia.
- SAE "C" Keyed 1.3" Dia., 5/16" Key
- SAE "BB" 15T Spline 1.0" Dia.

MOUNTING FLANGES:

- SAE "B" 2-Bolt
- SAE "C" 2-Bolt
- SAE "B" 2/4-Bolt
- SAE "B" 4-Bolt
- SAE "C" 4-Bolt

PORTING:

- SAE/ODT, Split Flange

DIMENSIONS IN.(MM) - SINGLE

- Dim A: 6.00 (152.4)
- Dim B: 7.06 + GW (179.3 + GW)
- Dim C: 5.75 (146.1)
- Dim D: 7.12 (180.8)
- Dim E: 7.12 (180.8)

BOLT DIAMETER

- 5/16"-11 UNC

DIMENSIONS IN.(MM) - TANDEM

- Dim A: 6.00 (152.4)
- Dim B: 10.25 + TGW (260.4 + TGW)
- Dim C: 5.75 (146.1)
- Dim D: 7.69 (195.3)
- Dim BC: 3.50 (88.9)

THRUST PLATE THICKNESS

- Each plate: 0.25 in. (2 Req.)

Notes:

A = Doweled

B = Add specified weight per each additional single section.

GW = Gear Width

TGW = Total Gear Width

BUSHING DESIGN CONTINUED

Z Series (Ref. P/M Series): Z*40 (*365)^A

SPECIFICATIONS (GEAR WIDTH)	0.5	0.75	1	1.25	1.5	1.75	2	2.25	2.5	2.75	3
Housing Width (in.)	-	1.25	1.5	1.75	2	2.25	2.5	2.75	3	-	-
Displacement cu.in. (cc.)	-	2.7 (44.3)	3.6 (59.0)	4.5 (73.8)	5.4 (88.5)	6.30 (103.3)	7.20 (118.0)	8.10 (132.8)	9.00 (147.5)	-	-
GPMt (LPM) @ 1,000 RPM	-	11.7 (44.3)	15.6 (59.0)	19.5 (73.8)	23.4 (88.5)	27.3 (103.3)	31.2 (118.0)	35.1 (132.8)	39.0 (147.5)	-	-
Min. RPM	-	900	900	900	900	900	900	900	900	-	-
Max. RPM	-	3,000	3,000	3,000	3,000	3,000	3,000	3,000	3,000	-	-
Max. Pressure PSI (BAR)	-	3,500 (241)	3,500 (241)	3,500 (241)	3,500 (241)	3,500 (241)	3,500 (241)	3,250 (224)	3,000 (207)	-	-
Approx. Wt. lbs.(Kg.) - Single	-	53.5 (24.3)	56 (25.4)	58.5 (26.5)	61 (27.7)	63.5 (28.8)	66 (29.9)	68.5 (31.1)	71 (32.2)	-	-
Approx. Wt. lbs.(Kg.) - Tandem ^B	-	53.5 (24.3)	57 (25.4)	58.5 (26.5)	62 (27.7)	63.5 (28.8)	67 (29.9)	68.5 (31.1)	72 (32.2)	-	-
MOTOR DATA: Motor Torque and HP values shown below are based on 1,000 RPM per 1,000 PSI, no efficiency values are in the calculations for GPMt. Maximum pressure ratings are the same as the pumps shown above.											
Motor input GPMt @ 1,000 RPM	-	11.7	15.6	19.5	23.4	27.3	31.2	35.1	39	-	-
Motor/Output Torq. in.lbs. @ 1,000 RPM	-	430.2	573.6	717.0	860.4	1003.8	1147.2	1290.6	1434.0	-	-
Motor/Output HP - Minimum	-	6.8	9.1	11.4	13.7	15.9	18.2	20.5	22.8	-	-
Motor Min. RPM	-	900	900	900	900	900	900	900	900	-	-
Motor Max. RPM	-	3,000	3,000	3,000	3,000	3,000	3,000	3,000	3,000	-	-

SHAFT OPTIONS:

- SAE "B" 13T Spline, 0.88" Dia.
- SAE "C" Keyed 1.3" Dia., 3/16" Key
- SAE "C" 14T Spline, 1.3" Dia.

MOUNTING FLANGES:

- SAE "B" 2-Bolt
- SAE "C" 2-Bolt
- SAE "B" 4-Bolt
- SAE "C" 4-Bolt

PORTING:

- SAE/ODT, Split Flange

DIMENSIONS IN (MM) - SINGLE

- Dim A: 7.25 (184.2)
- Dim B: 7.31 + GW (185.7 + GW)
- Dim C: 6.25 (158.8)
- Dim D: 7.38 (187.5)
- Dim E: 7.38 (187.5)

BOLT DIAMETER

- 5/16-11 UNC

DIMENSIONS IN (MM) - TANDEM

- Dim A: 7.25 (184.2)
- Dim B: 11.38 + TGW (289.1 + TGW)
- Dim C: 6.25 (158.8)
- Dim D: 8.38 (212.9)
- Dim BC: 4.00 (101.6)

THRUST PLATE THICKNESS

- Each plate: 0.25 in. (2 Req.)

Notes:

A = Doweled

B = Add specified weight per each additional single section.

GW = Gear Width

TGW = Total Gear Width

BEARING PUMP/MOTOR DIMENSIONS

(Single & Tandem Shown. Call for additional sections)

Z*10,13,16,19,22,26,28

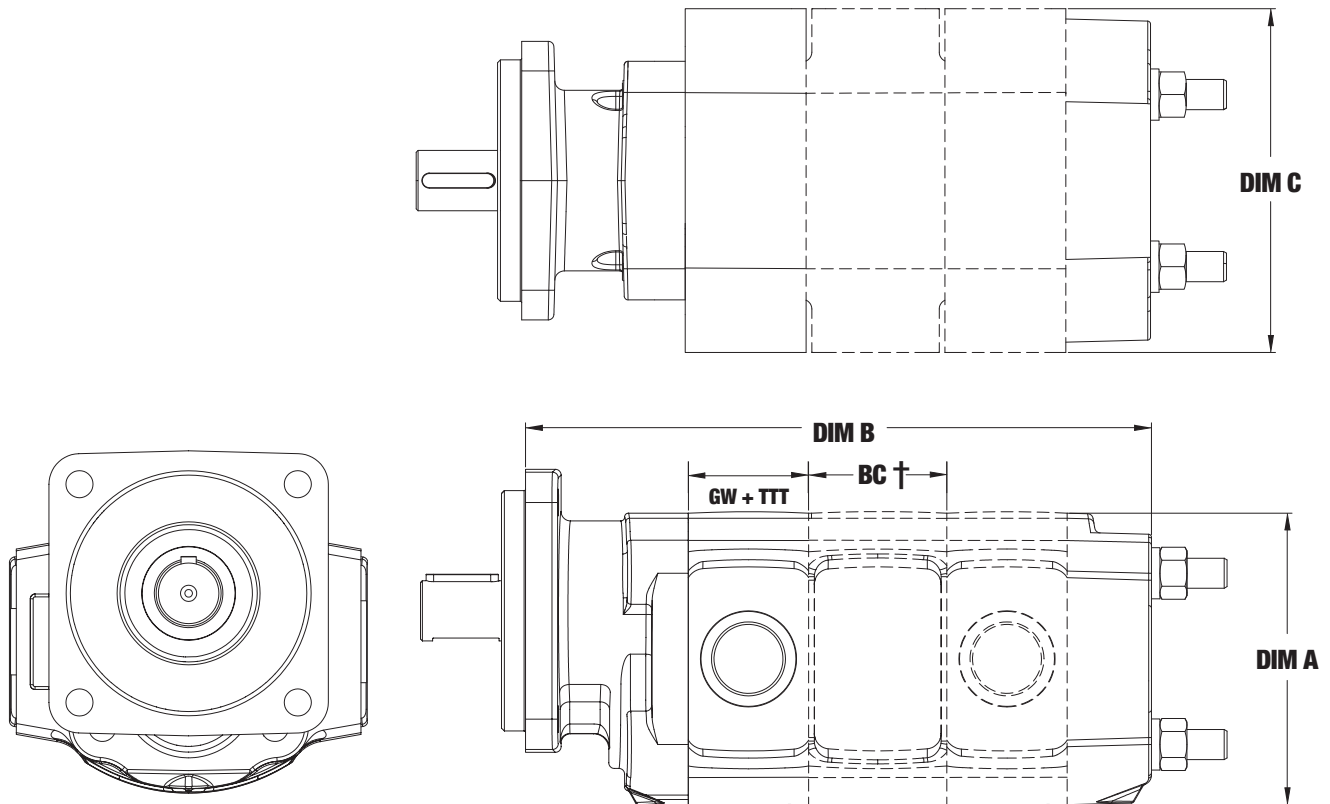

Notes:

† = Tandem Pump only (Dashed lines represent tandem additions)

BC = Bearing Carrier or Bushing Carrier

GW = Gear Width

TTT = Total Thrust Plate Thickness

BUSHING PUMP/MOTOR DIMENSIONS

(Single & Tandem Shown. Call for additional sections)

Z*32,34,38,40

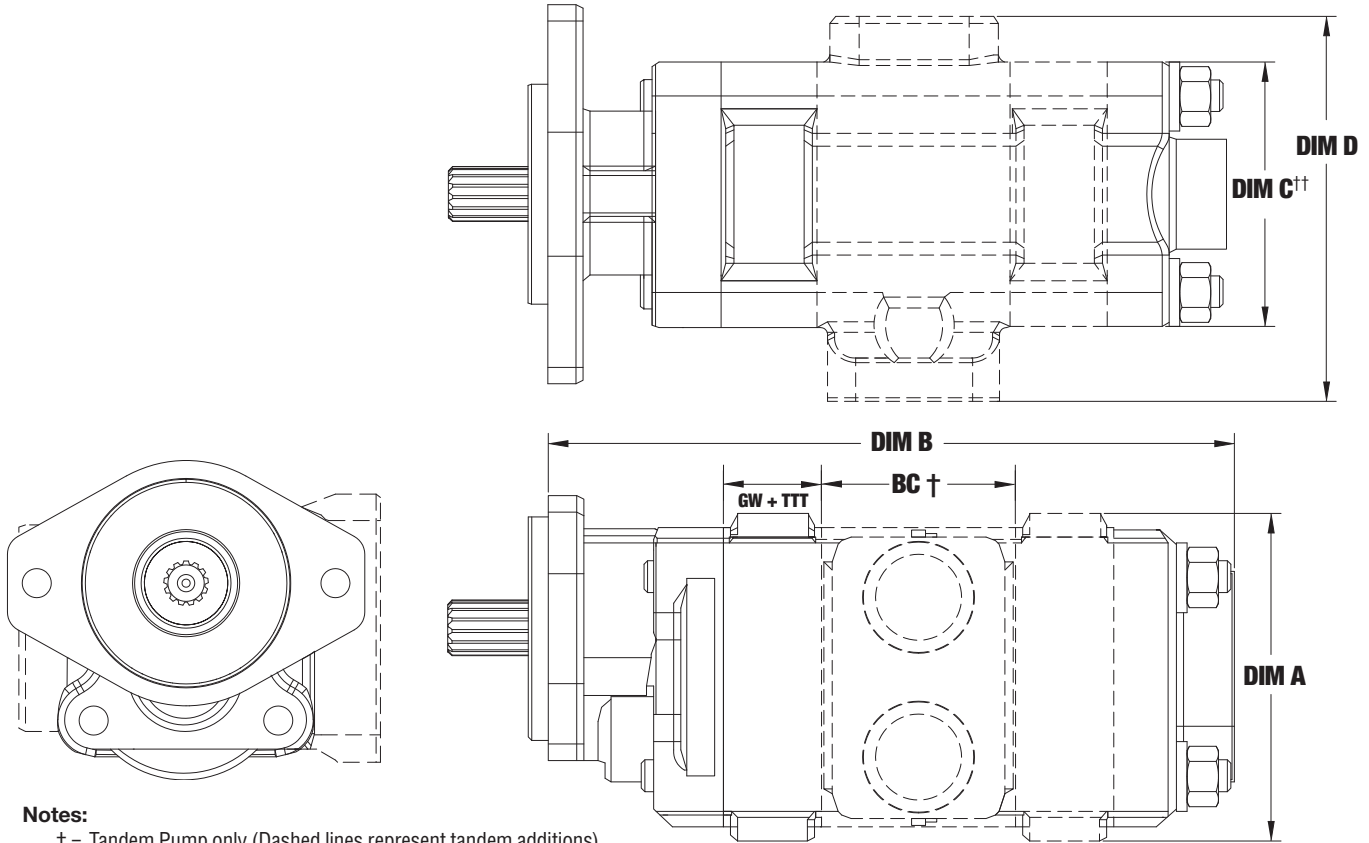

Notes:

- † = Tandem Pump only (Dashed lines represent tandem additions)
- †† = See page 7 (Dim E) for rear cover width with ports.
- BC = Bearing Carrier or Bushing Carrier
- GW = Gear Width
- TTT = Total Thrust Plate Thickness

PUMP/MOTOR ROTATION & PORTS

To determine which port is the inlet port on a bi-rotational pump, consider that as oil enters the pump, it must travel around the outside of the gears, rather than going through the center. As the gears “squeeze” together, the oil is forced out. Determine which way the shaft will turn, and plumb accordingly. For reference, the prime mover is classified as a PTO (i.e., power take-off.)

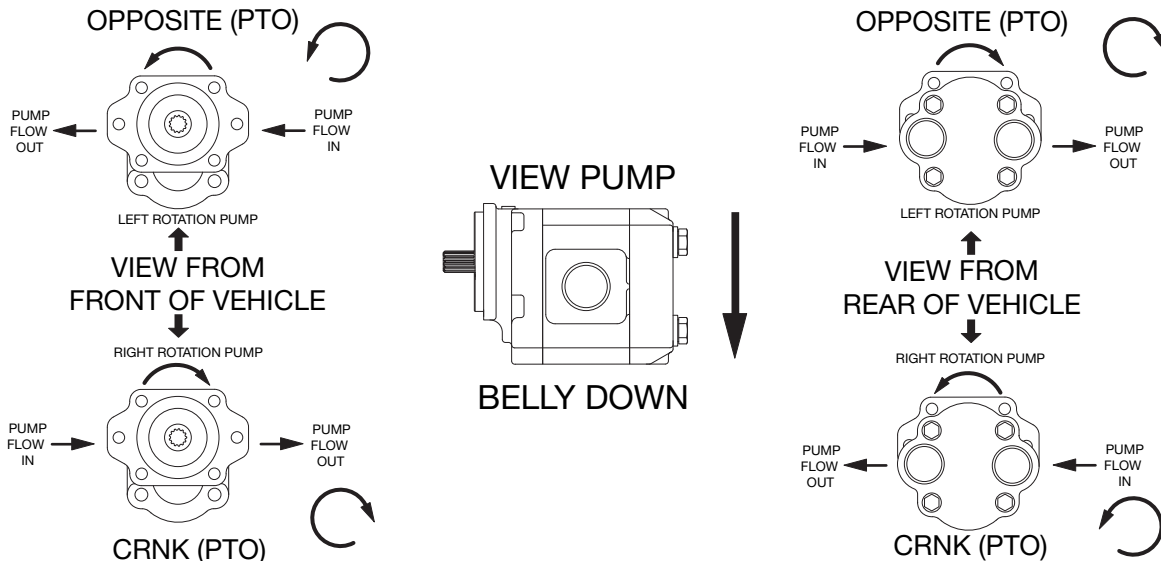

REAR PUMP DIMENSIONS (REF.)

(Single & Tandem Shown. Call for additional sections)

BUSHING STYLE

(REF. 4 BOLT)

Z Series: 32, 34, 38, 40

(See pages 4–5)

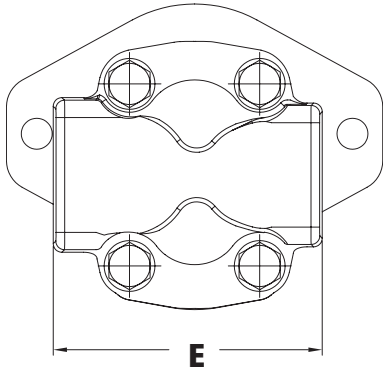

BEARING STYLE

(REF. 4 BOLT)

Z Series: 10, 13, 16, 19, 22

(See page 3)

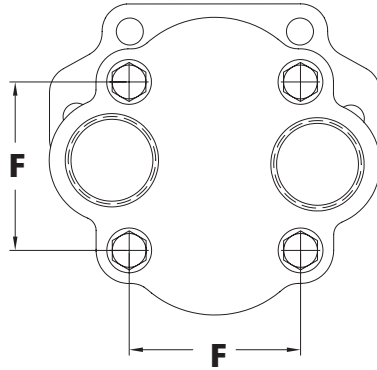

BEARING STYLE

(REF. 8 BOLT)

Z Series: 26, 28

(See page 3)

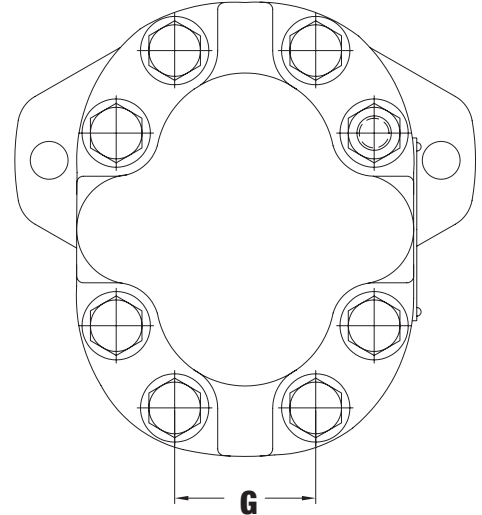

SHAFT TORQUE LIMITATION

The pump input shaft can withstand torques up to the designed shaft torque limitation (STL). This figure is based on multiplying the pump cubic inch displacement \times the pump pressure (ie: $D \times P \leq STL$). Tandem pumps are two pumps with individual calculated STLs added together not to exceed limitation figures.

Shaft Style	Integral Shaft & Gear	Two Piece Style
Z10/Z13/Z16 Series (Ref. 20,30,31)		
1" dia. 6T Spline	--	23529
0.75" dia. Keyed	--	8137
Clutch Pump Taper	--	9078
SAE "A" Spline, 5/8 9T	--	5098
SAE "B" Spline, 7/8 13T	15490	11471
SAE "B" Key, 7/8" dia.	9510	9510
SAE "BB" Spline, 1" 15T	23824	23824
SAE "BB" Key, 1.00" dia.	14216	11471
SAE "C" Spline, 1 1/4" 14T	--	11471
Connecting Shaft	--	11471
Z19/Z22 Series (Ref. 50,51)		
SAE "B" Spline, 7/8 13T	15641	15641
SAE "BB" Spline, 1" 15T	24103	24103
SAE "BB" Key, 1.00" dia.	14359	14359
SAE "C" Spline, 1 1/4" 14T	33077	21795
SAE "C" Key 1.25" dia.	27949	21795
Connecting Shaft	--	21795
Z26/Z28 Series (Ref. 75,76)		
SAE "C" Spline, 1 1/4" 14T	32922	32922
SAE "C" Key 1.25" dia.	30864	30864
Connecting Shaft	--	41152

Shaft Style	Integral Shaft & Gear	Two Piece Style
Z32 Series (Ref. 315)		
SAE "A" Spline, 5/8 9T	5528	--
SAE "A" Key, 5/8" dia.	4472	--
SAE "B" Spline, 7/8 13T	16646	--
SAE "B" Key, 7/8" dia.	12298	--
Connecting Shaft	--	6894
Z34 Series (Ref. 330)		
SAE "B" Spline, 7/8 13T	16569	12255
SAE "B" Key, 7/8" dia.	12255	12255
SAE "BB" Spline, 1" 15T	25490	12255
SAE "BB" Key, 1.00" dia.	18235	12255
SAE "C" Spline, 1 1/4" 14T	--	12255
Connecting Shaft	--	12255
Z38 Series (Ref. 350)		
SAE "B" Spline, 7/8 13T	16538	11538
SAE "BB" Spline, 1" 15T	25385	23077
SAE "BB" Key, 1.00" dia.	18205	18205
SAE "C" Spline, 1 1/4" 14T	48974	23077
SAE "C" Key 1.25" dia.	35641	23077
Connecting Shaft	--	23077
Z40 Series (Ref. 365)		
SAE "B" Spline, 7/8 13T	18036	14403
SAE "C" Spline, 1 1/4" 14T	53214	49177
SAE "C" Key 1.25" dia.	38571	44444
Connecting Shaft	--	49177

ONE-YEAR PUMP WARRANTY

The Muncie Cast Iron Pump “Z Product Group” is warranted against any defect in material and workmanship which existed at the time of sale by Muncie, according to the following provisions, subject to the requirements that the Pump must be used only in accordance with catalogue and package instructions.

The Pump is warranted for a period of one year from the date of installation. If during the warranty period the Pump fails to operate to Muncie’s specifications due to a defect in any part in material or workmanship that existed at the time of sale by Muncie, the defective part will be repaired or replaced, at Muncie’s election, at no charge, if the defective part is returned to Muncie with transportation prepaid.

WARNING: The above warranty shall terminate if any alterations or repairs are made to the Pump other than at Muncie Power Products, or if the Pump is used on any equipment other than the equipment upon which it is first installed.

THE FOREGOING WARRANTIES ARE IN LIEU OF ALL OTHER OBLIGATIONS AND LIABILITIES, INCLUDING NEGLIGENCE AND ALL WARRANTIES OF MERCHANTABILITY AND SUITABILITY, EXPRESSED OR IMPLIED, AND STATE MUNCIE’S ENTIRE AND EXCLUSIVE LIABILITY AND BUYER’S EXCLUSIVE REMEDY FOR ANY CLAIM OF DAMAGES IN CONNECTION WITH THE SALE, REPAIR OR REPLACEMENT OF THE ABOVE GOODS, THEIR DESIGN, INSTALLATION OR OPERATION. MUNCIE WILL IN NO EVENT BE LIABLE FOR ANY DIRECT, INDIRECT, SPECIAL, INCIDENTAL OR CONSEQUENTIAL DAMAGES WHATSOEVER, AND OUR LIABILITY UNDER NO CIRCUMSTANCES WILL EXCEED THE CONTRACT PRICE FOR THE GOODS FOR WHICH LIABILITY IS CLAIMED.



A Member of the Interpump Group

MP10-02 (Rev. 05-22)

201 East Jackson Street, Muncie, Indiana 47305
800-367-7867 • Fax: 765-284-6991 • info@munciepower.com

Specifications are subject to change without notice. Visit www.munciepower.com for warranties and literature. All rights reserved. © Muncie Power Products, Inc. (2010)