

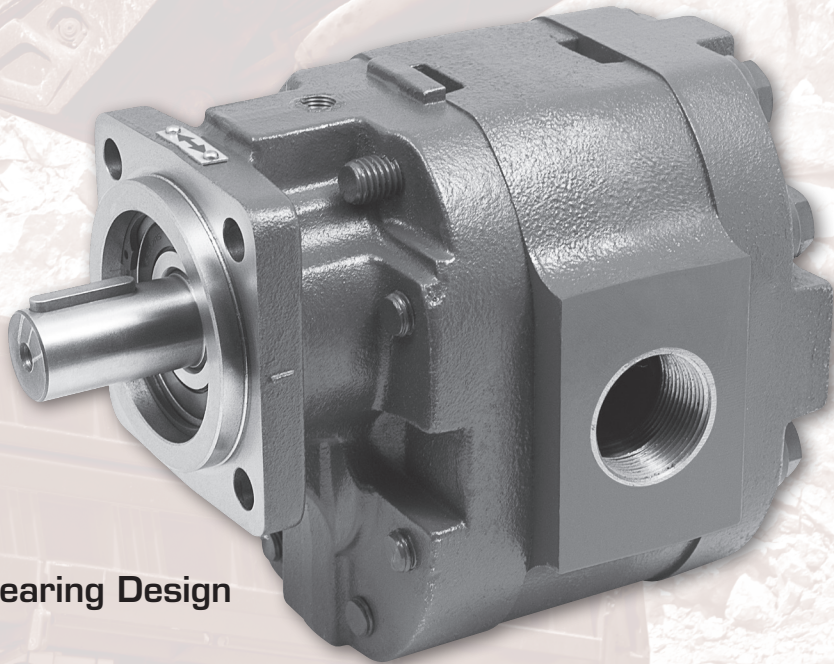

Z SERIES

Hydraulic Pump/Motor Product Group

Z28 Technical Specifications



Roller Bearing Design

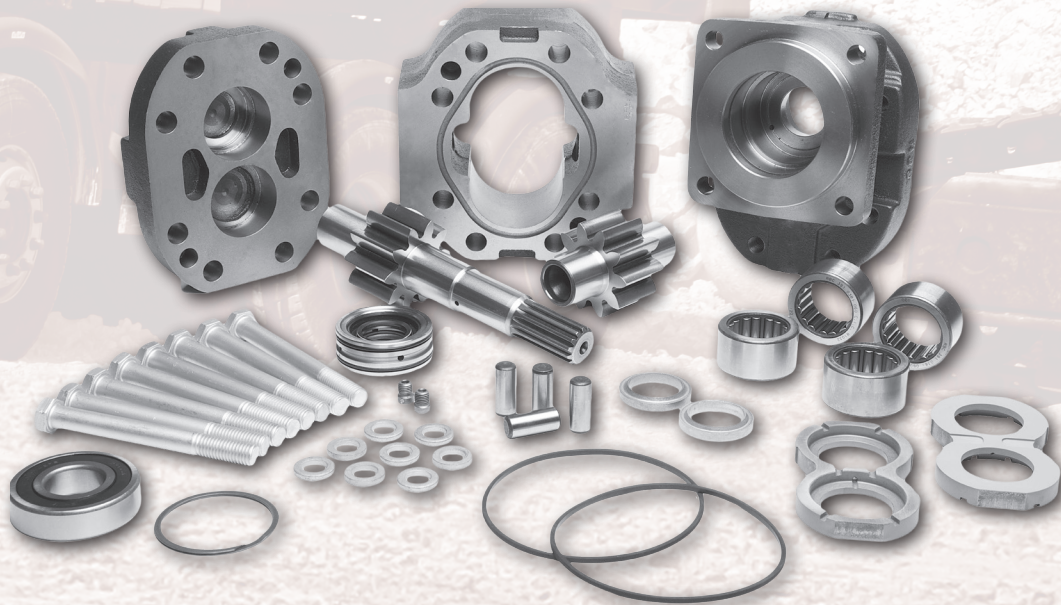

**Replacement parts for industry common pump/motor series.
Assemblies are built to your replacement or new installation requirements.**

Z28 TECHNICAL SPECIFICATIONS

Muncie Power Product's "Z" series gear pump/motor assemblies are custom built to your replacement or new installation requirements. The Z28 series offer numerous shaft, flange and port arrangement options to fit a wide variety of application needs. Rigid one-piece drive shafts and pressure balancing wear plates provide top efficiency, while high strength cast iron housings provide durability for the toughest environment.

Muncie Power Products has served the mobile application industry for over 75 years. We strive to provide the highest quality products and support. Call today and let us give you the power to your hydraulic system.

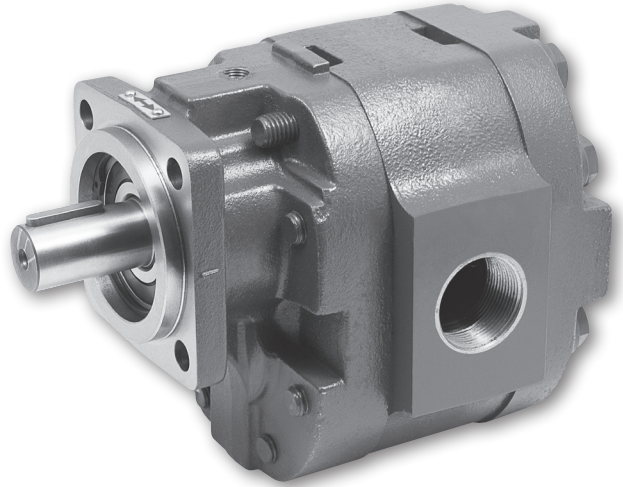

Flows up to 127 GPM, Pressures up to 3,000 PSI, Speeds to 2,400 RPM, Roller Bearing Design

APPLICATIONS

Construction • Mining • Forestry • Truck • Agriculture • Marine • Material Handling

SPECIFICATION	GEAR WIDTH									
	0.75	1.00	1.25	1.50	1.75	2.00	2.25	2.50	2.75	3.00
Housing Width, in	1.75	2.00	2.25	2.50	2.75	3.00	3.25	3.50	3.75	4.00
Displacement, in ³ (cc)	3.08 (50.4)	4.10 (67.2)	5.13 (84.0)	6.15 (100.8)	7.18 (117.6)	8.20 (134.4)	9.23 (151.2)	10.25 (168.0)	11.28 (184.8)	12.30 (201.6)
GPMt (LPM) @ 1,000 RPM	13.3 (50.4)	17.7 (67.2)	22.2 (84.0)	26.6 (100.8)	31.1 (117.6)	35.5 (134.4)	40.0 (151.2)	44.4 (168.0)	48.8 (184.8)	53.2 (201.6)
Min. RPM	900	900	900	900	900	900	900	900	900	900
Max. RPM	2400	2400	2400	2400	2400	2400	2400	2400	2400	2400
Max. Pres., PSI (BAR)	3,000 (207)	3,000 (207)	3,000 (207)	3,000 (207)	3,000 (207)	2,500 (172)	2,500 (172)	2,500 (172)	2,000 (138)	2,000 (138)
Approx. Wt., lbs. (Kg) - Single Unit	70 (32)	72 (33)	75 (34)	77 (35)	80 (36)	82 (37)	85 (39)	87 (40)	90 (41)	92 (42)
Approx. Wt., lbs. (Kg) - Multiple Unit*	57 (26)	59 (27)	62 (28)	64 (29)	67 (31)	69 (32)	72 (33)	74 (34)	77 (35)	79 (36)
Motor Data: Motor torque and HP values shown below are based on 1,000 RPM per 1,000 PSI, no efficiency values are in the calculations for GPMt. Maximum pressure ratings are the same as above.										
Motor Input, GPMt (LPM) @ 1,000 RPM	13.3 (50.4)	17.7 (67.2)	22.2 (84.0)	26.6 (100.8)	31.1 (117.60)	35.5 (134.4)	40.0 (151.2)	44.4 (168.0)	48.8 (184.8)	53.2 (201.6)
Motor Output Torq, in.lbs. @ 1,000	489.0	650.8	816.3	978.1	1143.5	1305.3	1470.8	1632.6	1794.4	1956.2
Motor Output HP @ 1,000 PSI	7.8	10.3	13.0	15.5	18.1	20.7	23.3	25.9	28.5	31.0
Motor Min. RPM	900	900	900	900	900	900	900	900	900	900
Motor Max. RPM	2,400	2,400	2,400	2,400	2,400	2,400	2,400	2,400	2,400	2,400

*Add specified weight per each additional single section

PRODUCT FEATURES

- 10 pump sizes available with flows between 13.3 - 53.2 GPM (50.4 - 201.6 LPM) @ 1,000 RPM.
- High grade cast iron construction for durability and high performance product requirements
- Up to 3,000 PSI (207 BAR) capability for severe requirements
- High speed, heavy-duty roller bearing design can withstand severe applications and provide long product life
- Standard or Metric porting is available in numerous configurations.
- Multiple shaft and flange options available to fit your application needs

Z28 SERIES DESCRIPTION

The largest of the "Z" series bearing pumps, the Z28 series offers high-volume flow rates to supply the most demanding of applications. The Z28's 8-bolt, doweled construction provides superior structural integrity to achieve higher pressure capabilities. The Z28's large size make it ideal for tough applications and is a top candidate for refuse equipment such as front, side and rear loaders. The Z28 series is similar to Parker's P76 and Permcos's P7600.



Z28 MODEL NUMBER CONSTRUCTION

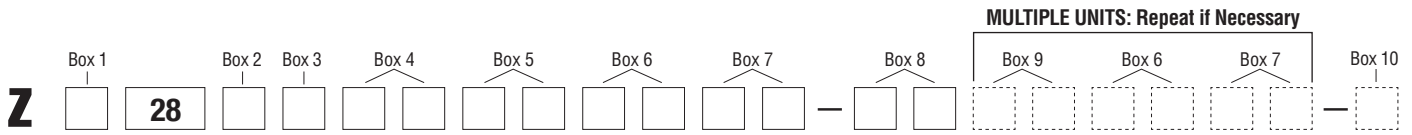

BOX 1 PUMP/MOTOR	
CODE	DESCRIPTION
P	Pump
M	Motor

BOX 2 UNIT CONFIGURATION	
CODE	DESCRIPTION
A	Single Unit
B	Tandem Unit
C	Single or Tandem w/ 2 piece shaft (OB bearing required)

BOX 3 UNIT TYPE & ROTATION	
CODE	DESCRIPTION
1	Pump, CW, w/o OB Bearing
2	Pump, CCW, w/o OB Bearing
4	Pump, CW, w/ OB Bearing
5	Pump, CCW, w/ OB Bearing
8	Motor, Bi-rotational, w/ OB Bearing, ¼" NPT drain
9	Motor, Bi-rotational, w/o OB Bearing, ¼" NPT drain

BOX 4 FRONT COVER FLANGE TYPE	
CODE	DESCRIPTION
42	SAE "B" 4 Bolt, 4" Pilot Diameter
78	SAE "C" 4 Bolt, 5" Pilot Diameter
80	SAE "D" 4 Bolt, 6" Pilot Diameter
98	SAE "C" 2 Bolt, 5" Pilot Diameter

BOX 5 REAR COVER (REAR PORTS)					
TYPE	PORTING		CODE		
	LEFT	RIGHT	SINGLE	TANDEM	EXT. STUDS
Blank	-	-	BE	BI	BY
SAE	1.0	1.0	JE	JI	JY

DETERMINING ROTATION

To determine rotation of a unit, position unit with shaft facing you, "belly" down (see image below). A clockwise unit will flow left (inlet) to right (outlet). A counter-clockwise unit will flow from right (inlet) to left (outlet).

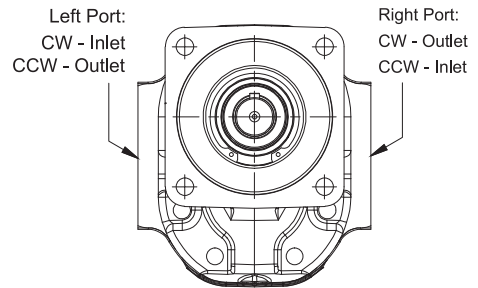

Z28 MODEL NUMBER CONSTRUCTION

BOX 6 GEAR HOUSING - PORTING													
HOUSING CODE (REF. BOX 7)				10	12	15	17	20	22	25	27	30	
GEAR WIDTH				1.00	1.25	1.50	1.75	2.00	2.25	2.50	2.75	3.00	
DISPLACEMENT (CIR)				4.10	5.13	6.15	7.18	8.20	9.23	10.25	11.28	12.30	
MAX PSI				3,000	3,000	3,000	3,000	2,500	2,500	2,500	2,000	2,000	
PORTING			CODE										
TYPE	IN	OUT	CW	CCW									
No Ports	-	-	AB	AB	X	X	X	X	X	X	X	X	X
SAE PORTS	1.0	0.75	EJ	EG	X ^{1,2}								
	1.25	0.75	EK	EH		X ¹							
	1.0	-	AC	AD		X ²	X						
	-	1.0	AD	AC		X ²	X						
	1.0	1.0	AF	AF		X ²	X						
	1.25	1.0	AJ	AG		X ^{1,2}	X ¹						
	1.50	1.0	AK	AH			X ¹						
SPLIT FLANGE PORTS	1.0	0.75	UL	UG	X								
	1.0	1.0	OF	OF	X	X	X	X	X				
	1.25	1.0	OJ	OG	X ¹	X ¹							X
	1.5	1.0	OK	OH		X ¹	X ¹	X ¹					
	1.25	1.25	OL	OL		X ²	X	X	X	X		X	X
	1.5	1.25	OP	OM		X ^{1,2}	X ¹	X ¹	X				
	1.5	-	OE	OU					X				
	-	1.5	OU	OE					X				
	1.5	1.5	OR	OR					X	X		X	X
	2.0	1.25	OQ	ON				X ¹	X ¹	X ¹		X	X
	2.0	1.5	OV	OS					X ¹	X ¹		X	X
	2.0	2.0	OX	OX								X	X
2.0	1.5	OW	OT						X ¹		X ¹	X ¹	

BOX 7 GEAR WIDTH (HOUSING CODE)				
CODE	GEAR WIDTH	IN ³ /REV	CM ³ /REV	MAX PRESSURE
07	0.75	3.08	50.4	3,000 PSI (207 Bar)
10	1.00	4.10	67.2	3,000 PSI (207 Bar)
12	1.25	5.13	84.0	3,000 PSI (207 Bar)
15	1.50	6.15	100.8	3,000 PSI (207 Bar)
17	1.75	7.18	117.6	3,000 PSI (207 Bar)
20	2.00	8.20	134.4	2,500 PSI (172 Bar)
22	2.25	9.23	151.2	2,500 PSI (172 Bar)
25	2.50	10.25	168.0	2,500 PSI (172 Bar)
27	2.75	11.28	184.8	2,000 PSI (138 Bar)
30	3.00	12.30	201.6	2,000 PSI (138 Bar)

- Notes:**
- 1 INLET port is low pressure only
 - 2 PRESSURE port MAX = 2,500 PSI
 - Shaded cells represent Bi-rotational (motor) capabilities
 - "X" represents port availability per housing code (gear width)



Z28 MODEL NUMBER CONSTRUCTION

BOX 8 SHAFT TYPE	
CODE	DESCRIPTION
07	SAE "C" 1.25" 14T Spline
11	SAE "C" Keyed, 1.25" Dia., 0.313" Key

BOX 10 CONNECTING SHAFT (MULTIPLE UNITS ONLY)	
CODE	DESCRIPTION
1	Connecting Shaft

Notes: 1 Used when only one adjacent gear housing has an inlet port.

***Bearing Carrier View Orientation**

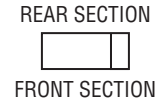

BOX 9 BEARING CARRIER		PUMP ONLY (IF NECESSARY)				
PORTING	CW CONFIG*	CCW CONFIG*	IN	OUT	CW CODE	CCW CODE
COMMON INLET PASSAGE			-	-	C	D
			-	-	A ¹	U ¹

BOX 9 BEARING CARRIER		MOTOR ONLY (IF NECESSARY)		
PORTING	BI-ROT. CONFIG.*	IN	OUT	BI-ROT. CODE
NO PORTS		-	-	B
SAE PORTS		1.00	1.00	CC
		1.25	1.25	BB
SPLIT FLANGE PORTS		1.00	1.00	LL
		1.25	1.25	MM
		1.5	1.5	NN



Z28 PUMP/MOTOR DIMENSIONS (REF. ONLY)

Rear View

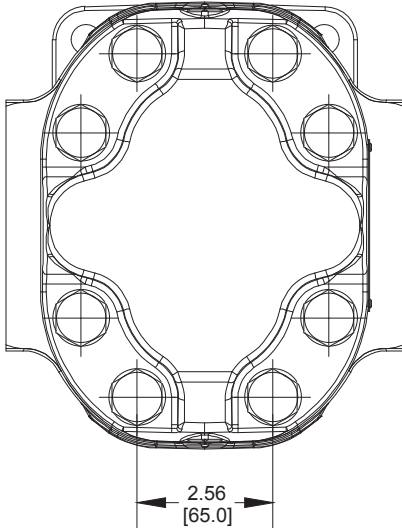

Front View

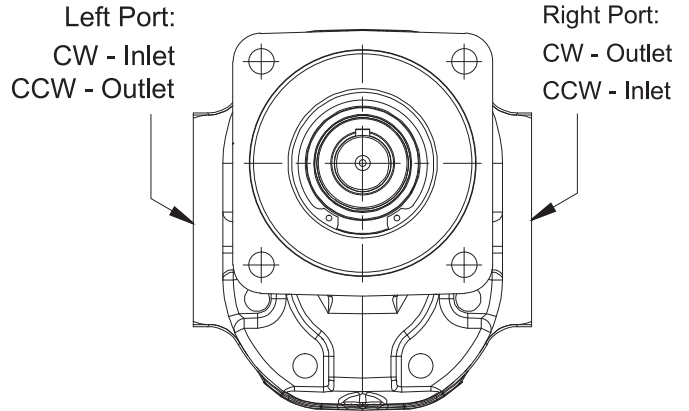

CW ROTATION



CCW ROTATION



To determine rotation of a unit, position unit with shaft facing you, "belly" down (ref. front view). A clockwise unit will flow left (inlet) to right (outlet). A counter-clockwise unit will flow from right (inlet) to left (outlet).

Side View

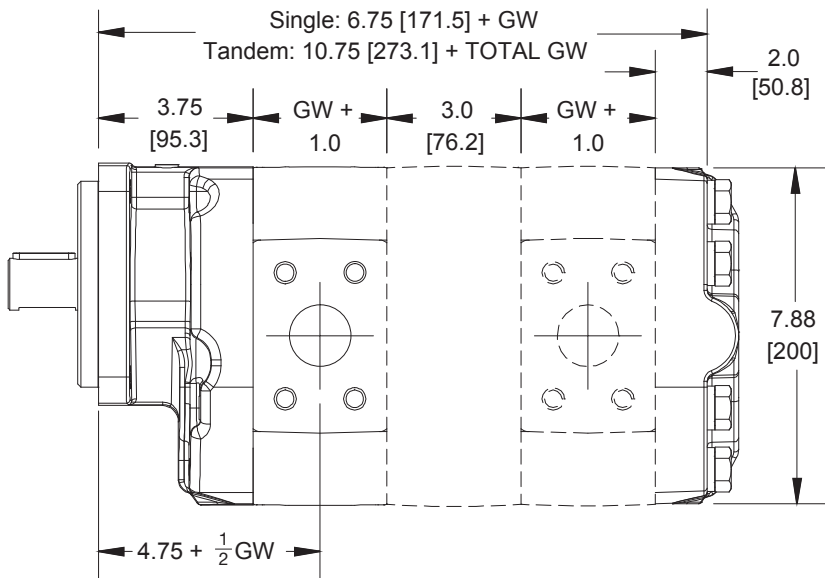

Dimensional Notes

- GW = Gear Width
- Bearing carrier width will vary depending on port type (multiple units only)
- Dashed lines represent tandem addition, delete for single unit.
- Z28 Bolt Diameter: $\frac{5}{8}$ -11UNC
- Thrust Plate Thickness: 0.50" each (2 required per gear housing)
- Doweled construction is standard

Top View

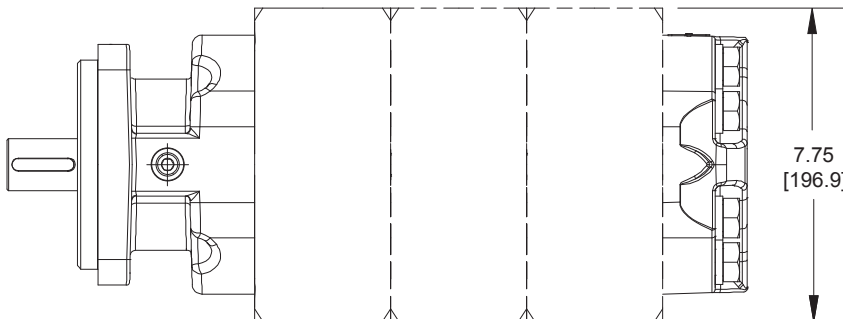

“Z” Product General Information *(Applies to all series unless noted)*

OIL RECOMMENDATIONS

Muncie Power Products does not promote specific manufacturer's brands of oil, but does recommend the use of quality petroleum based hydraulic fluids. Different climate temperatures require that the oil viscosity be appropriate for the operating conditions. Consult the oil manufacturer for your exact application needs. (Note: NEVER dilute the hydraulic fluid for cold weather operation with, including but not limited to, diesel fuel, kerosene, etc.)

- Oil Viscosity: 60-1,000 SSU (10.5-216 cST) for continuous operation. Viscosity should not exceed 7,500 SSU (1600 cST) MAX at startup.
- Special Fluids: Biodegradable and water-glycol type fluids are ok for use with bushing design ONLY, NOT roller bearing type products.

INLET / OUTLET CONDITION

- Maximum inlet vacuum should not exceed 5 in.Hg. across all operating RPM's and temperature conditions.
- An undersized inlet port size could have maximum RPM limitations.
- An oversized outlet port size could have maximum pressure limitations.

OPERATING TEMPERATURES

Proper control of the system operating temperature is critical for long product life and the protection of all other hydraulic components as well.

- Optimum operating temperatures: 100-140°F (37.8-60°C)
- MAX Continuous temperature: 180°F (82°C)
- MAX Intermittent temperature: 200°F (93°C)

HOSE SIZING

Hydraulic hose must be properly sized based on the oil velocity in feet per second (FPS) and of the appropriate type (SAE rating) for the specified rate of flow and pressure. The following are hose recommendations for common applications; hose requirements may differ for non-standard applications.

- Inlet hose: 2-4 FPS, SAE 100R4 type
- Pressure hose: 7-15 FPS, SAE 100R2 type
- Return hose: 4-8 FPS, SAE 100R1 type

FILTRATION

Proper filtration is vital to the life of any hydraulic system, as it helps protect hydraulic components from foreign objects which may have entered the system.

- Return Line Filters: Return filters are always recommended with a minimum 10 micron rating. Some applications require better filtration with an absolute rating and possibly 3 or 6 micron media.
- Pressure Filters: Pressure filter are not typically required for gear pump applications, but they are available if desired.
- Suction Strainers: Suction strainers are very useful in catching large objects. Strainers should never be sized smaller than 100 mesh (149 micron), and should always include a 3 PSI (0.2 BAR) bypass.

STARTUP OF A NEW OR RE-BUILT PUMP

Before startup of a new or re-built pump, the installer should always do the following:

- Properly install the pump and all other necessary components
- Fill the pump ports with clean oil
- Back off the main relief valve, or have complete confidence that it is set correctly
- Connect all lines for proper operation
- Engage the pump and allow to run under a no load condition at engine idle for 2 minutes
- If ok, increase engine to normal operating RPM and allow to run for another 2 minutes
- If no problems are detected, reset (if needed) the main relief valve to its proper setting with engine at operating RPM.
- Bushing pumps require a "Power & Flush" startup procedure
- Bushing motors must be broken in before installation

SHAFT TORQUE LIMITATION

The pump output shaft can withstand torques up to the designed shaft torque limitation (STL). This figure is based on multiplying the pump cubic inch displacement x the pump pressure (ie: $D \times P \leq STL$). Tandem pumps are two pumps with individual calculated STL's added together not to exceed limitation figures.

Z28 SERIES (REF. 76)

SHAFT STYLE	INTEGRAL SHAFT & GEAR	TWO PIECE STYLE
SAE "C" 1¼" 14T Spline	32922	32922
SAE "C" Key, 1.25" dia.	30864	30864
Connecting Shaft	-	41152



ONE-YEAR PUMP/MOTOR WARRANTY

The Muncie Cast Iron Pump/Motor “Z Product Group” is warranted against any defect in material and workmanship which existed at the time of sale by Muncie Power Products, according to the following provisions, subject to the requirements that the pump/motor must be used only in accordance with catalog and package instructions.

The pump/motor is warranted for a period of one year from the date of installation. If during the warranty period the pump/motor fails to operate to Muncie’s specifications due to a defect in any part in material or workmanship that existed at the time of sale by Muncie Power Products, the defective part will be repaired or replaced, at Muncie’s election, at no charge, if the defective part is returned to Muncie with the transportation prepaid.

WARNING: The above warranty shall terminate if any alterations or repairs are made to the pump/motor other than at Muncie Power Products, or if the pump is used on any equipment other than the equipment upon which it is first installed.

THE FOREGOING WARRANTIES ARE IN LIEU OF ALL OTHER OBLIGATIONS AND LIABILITIES, INCLUDING NEGLIGENCE AND ALL WARRANTIES OF MERCHANTABILITY AND SUITABILITY, EXPRESSED OR IMPLIED, AND STATE MUNCIE’S ENTIRE AND EXCLUSIVE LIABILITY AND BUYER’S EXCLUSIVE REMEDY FOR ANY CLAIM OF DAMAGES IN CONNECTION WITH THE SALE, REPAIR OR REPLACEMENT OF THE ABOVE GOODS, THEIR DESIGN, INSTALLATION OR OPERATION. MUNCIE WILL IN NO EVENT BE LIABLE FOR ANY DIRECT, INDIRECT, SPECIAL, INCIDENTAL OR CONSEQUENTIAL DAMAGES WHATSOEVER, AND OUR LIABILITY UNDER NO CIRCUMSTANCES WILL EXCEED THE CONTRACT PRICE FOR THE GOODS FOR WHICH LIABILITY IS CLAIMED.

Distributed by:

