



HS24 SERIES PTO

The 10-Bolt clutch shift PTO solution for limited clearance applications.



US Pat. 5,542,306

The HS24 Series PTO is specifically designed for the HINO 338 Series, but will fit other chassis with the Allison 3000 or 4000 Series transmission.

The sculptured housing clears mounting obstructions and provides a drop-in shift solenoid for a clean & simple installation.

- PROVEN CLUTCH SHIFT DESIGN
- DESIGNED TO FIT HINO 338 CHASSIS AND OTHER CHASSIS WITH ALLISON WORLD TRANSMISSIONS SERIES 3000 OR 4000
- DUCTILE IRON HOUSING WITH INTEGRAL SOLENOID
- 4-SPEED RATIOS
- TORQUE RATINGS FROM 325 FT.LB.
- INTEGRAL SHAFT BRAKE
- WIDE ARRAY OF DRIVELINE OUTPUTS AND HYDRAULIC PUMP MOUNTS

HS24 SERIES PTO

MODEL NUMBER CONSTRUCTION

HS 24 - A10 07 - H 3 K X

PTO Type

Clutch Shift — HS

Mounting

10-Bolt Mount, Sculptured Housing — 24

Transmission

Allison

Gear Data

10.10P RH — A10

Speed Ratio

06 — 0.56:1

07 — 0.70:1

09 — 0.87:1

12 — 1.15:1

Shifter Type

Electric/Hydraulic (12 Volt) — H

Electric/Hydraulic (24 Volt) — J

Less Activation Kit — P

Assembly Arrangement

3

Special Features

X — None

B — Hose Kit (HD Trans. R.S.)

D — Pulse Generator & SPD1001A

U — Pulse Generator

2 — Hose Kit Special 36"

3 — Hose Kit Special 17"

Output Types*

B — 1-1/4" Rd; 5/16" KW

K — SAE "B" 2 & 4 Bolt 7/8" - 13T

P — SAE "BB" 2 & 4 Bolt 1" - 15T

Q — SAE "A" 2-Bolt 7/8" - 13T

S — SAE "B" 2-Bolt 7/8" - 13T

T — SAE "A" 2-Bolt 3/4" - 11T

6 — SAE "B" 2-Bolt 7/8" - 13T

* Larger shaft options. I, D, or Z are not available.

HS24 DIMENSIONS

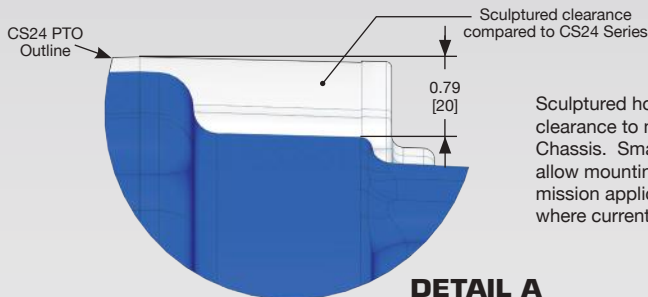
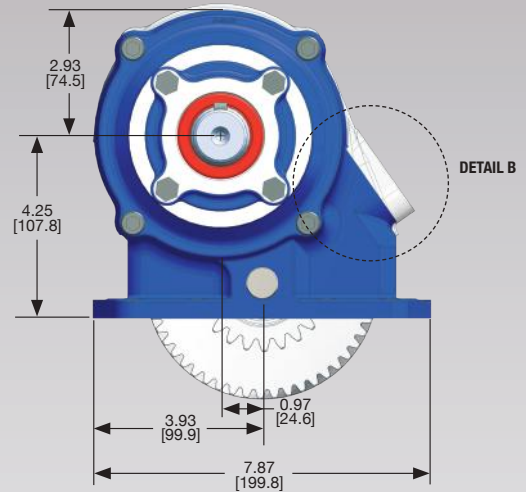
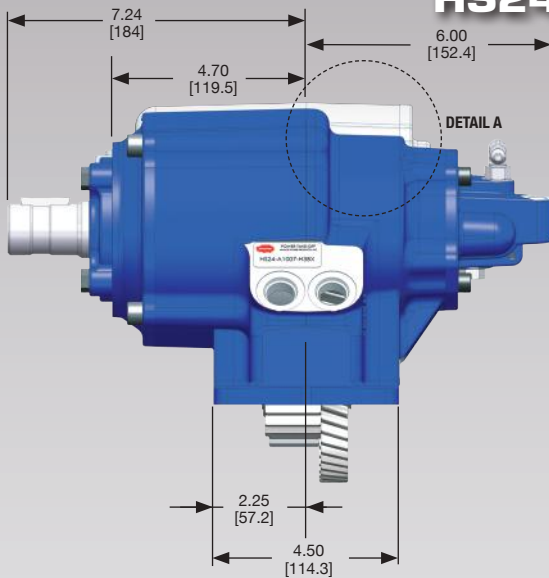

Sculptured housing design allows for clearance to motor mounts on Hino Chassis. Smaller overall housing can allow mounting on other 10-Bolt transmission applications. Can be used where current CS24 PTOs mount.

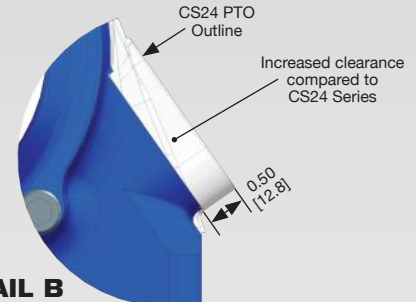

**Muncie®
Power
Products**