

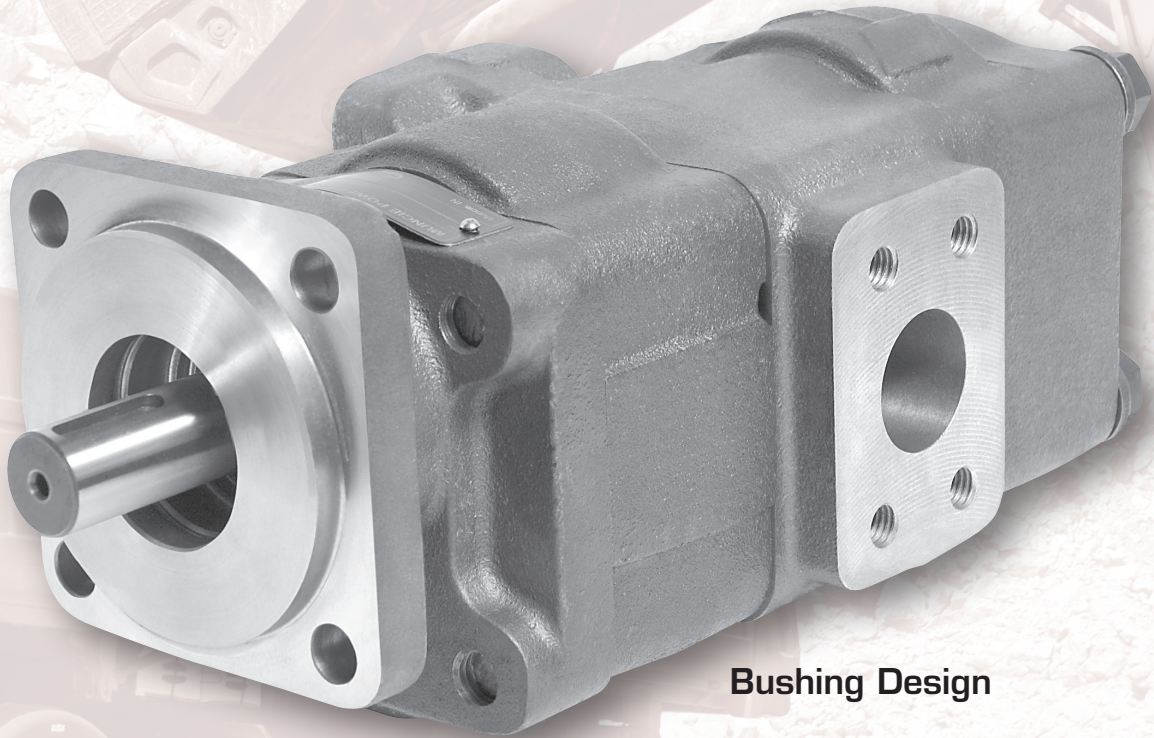

Z SERIES

Hydraulic Pump/Motor Product Group

Z32 Technical Specifications



Bushing Design

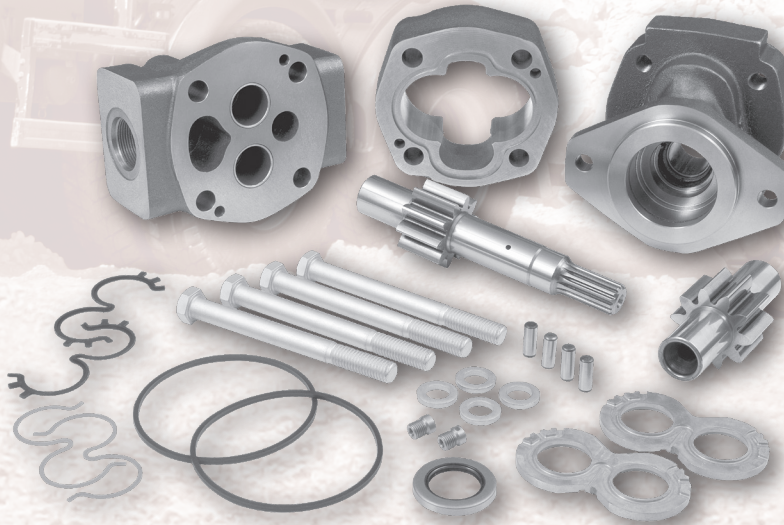

Replacement parts for industry common pump/motor series. Assemblies are built to match your replacement or to meet new installation requirements.

Z32 TECHNICAL SPECIFICATIONS

Muncie Power Product's "Z" series gear pump/motor assemblies are custom built to your replacement or new installation requirements. The Z32 series offers numerous shaft, flange and port arrangement options to fit a wide variety of application needs. Rigid one-piece drive shafts and pressure balancing wear plates provide top efficiency, while high strength cast iron housings provide durability for the toughest environment.

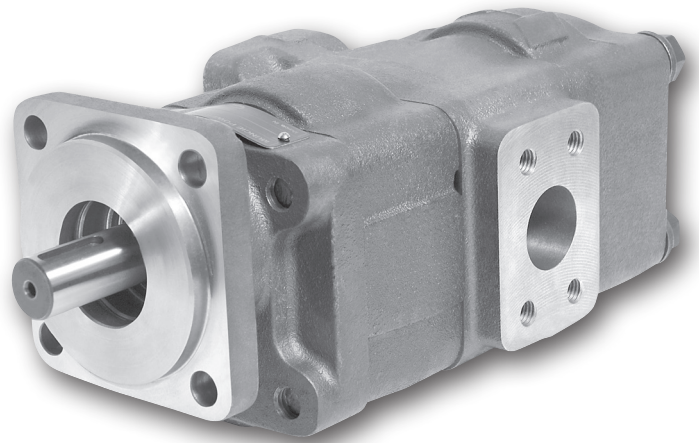

Flows up to 32 GPM, Pressures up to 3500 PSI, Speeds to 3000 RPM, Bushing Design

Muncie Power Products has served the mobile application industry for more than 75 years. We strive to provide the highest quality products and support. Call today and let us give you the power to your hydraulic system.

APPLICATIONS

Construction • Mining • Forestry • Truck • Agriculture • Marine • Material Handling

SPECIFICATION	GEAR WIDTH													
	0.375	0.50	0.625	0.75	0.875	1.00	1.125	1.25	1.375	1.50	1.625	1.75	1.875	2.00
Housing Width, in	0.875	1.00	1.125	1.25	1.375	1.5	1.625	1.75	1.875	2.00	2.125	2.25	2.375	2.5
Displacement, in ³ (cc)	0.47(7.6)	0.62(10.2)	0.78(12.7)	0.93(15.2)	1.09(17.8)	1.24(20.3)	1.40(22.9)	1.55(25.4)	1.71(27.9)	1.86(30.5)	2.02(33.0)	2.17(35.6)	2.33(38.1)	2.48(40.6)
GPMt (LPM) @ 1000 RPM	2.0(7.6)	2.7(10.2)	3.4(12.7)	4.0(15.2)	4.7(17.8)	5.4(20.3)	6.1(22.9)	6.7(25.4)	7.4(27.9)	8.1(30.5)	8.7(33.0)	9.4(35.6)	10.1(38.1)	10.7(40.6)
Min. RPM	900	900	900	900	900	900	900	900	900	900	900	900	900	900
Max. RPM	3000	3000	3000	3000	3000	3000	3000	3000	3000	3000	3000	3000	3000	3000
Max. Pres., PSI (BAR)	3500(241)	3500(241)	3500(241)	3500(241)	3500(241)	3500(241)	3500(241)	3500(241)	3500(241)	3300(228)	3100(214)	2900(200)	2700(186)	2500(172)
Approx. Wt., lbs. (Kg) - Single Unit	15.5(7.0)	16(7.3)	16.5(7.5)	17(7.7)	17.5(7.9)	18(8.2)	18.5(8.4)	19(8.6)	19.5(8.8)	20(9.1)	20.5(9.3)	21(9.5)	21.5(9.8)	22(10)
Approx. Wt., lbs. (Kg) - Multiple Unit*	15.5(7.0)	16(7.3)	16.5(7.5)	17(7.7)	17.5(7.9)	18(8.2)	18.5(8.4)	19(8.6)	19.5(8.8)	20(9.1)	20.5(9.3)	21(9.5)	21.5(9.8)	22(10)
Motor Data: Motor torque and HP values shown below are based on 1000 RPM per 1000 PSI, no efficiency values are in the calculations for GPMt. Maximum pressure ratings are the same as above.														
Motor Input, GPMt (LPM) @ 1000 RPM	2.0(7.6)	2.7(10.2)	3.4(12.7)	4.0(15.2)	4.7(17.8)	5.4(20.3)	6.1(22.9)	6.7(25.4)	7.4(27.9)	8.1(30.5)	8.7(33.0)	9.4(35.6)	10.1(38.1)	10.7(40.6)
Motor Output Torq, in-lbs @ 1000 RPM	73.5	99.3	125.0	147.1	172.8	198.6	224.3	246.4	272.1	297.8	319.9	345.6	371.4	393.4
Motor Output HP @ 1000 PSI	1.2	1.6	2.0	2.3	2.7	3.2	3.6	3.9	4.3	4.7	5.1	5.5	5.9	6.2
Motor Min. RPM	900	900	900	900	900	900	900	900	900	900	900	900	900	900
Motor Max. RPM	3000	3000	3000	3000	3000	3000	3000	3000	3000	3000	3000	3000	3000	3000

*Add specified weight per each additional single section

PRODUCT FEATURES

- 14 pump sizes available with flows between 2.0-10.7 GPM (7.6-40.6 LPM) @ 1000 RPM
- High grade cast iron construction for durability and high performance product requirements
- Up to 3500 PSI (241 BAR) capability to hold up in the toughest environments.
- Heavy duty, low friction bushing design can withstand severe applications and provide long product life
- SAE, NPT or Split Flange porting is available
- Multiple shaft and flange options available to fit your application needs

SERIES DESCRIPTION

The Z32 series is the smallest of the "Z" series bushing pumps. With 14 sizes available, the Z32 series offers a versatile lineup with many options to fit several different applications across many industries. Heavy duty bushing design makes for superior performance and reliability in the most extreme hydraulic applications. Strength, high efficiency and high endurance give the Z32 series long life capabilities in the toughest operating conditions. The Z32 is similar to Parker's 315 series and Permco's 124 series.



Z32 MODEL NUMBER CONSTRUCTION

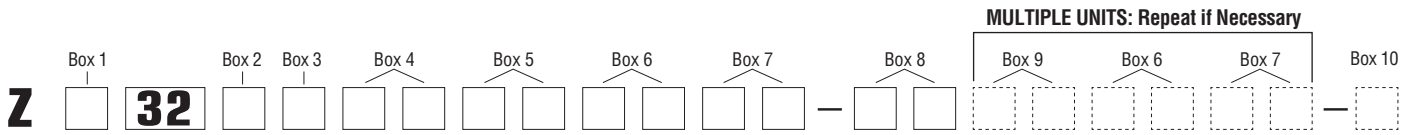

BOX 1 PUMP/MOTOR	
CODE	DESCRIPTION
P	Pump
M	Motor (Tandem motors not available)

BOX 2 UNIT CONFIGURATION	
CODE	DESCRIPTION
A	Single Unit
B	Tandem Unit (Extended Studs N/A)
L	Unit with extended studs

BOX 3 UNIT TYPE & ROTATION	
CODE	DESCRIPTION
1	Pump, CW, w/o OB Bearing
2	Pump, CCW, w/o OB Bearing
9	Motor, Bi-rotational, w/o OB Bearing, 1/4" SAE drain

BOX 4 FRONT COVER FLANGE TYPE	
CODE	DESCRIPTION
42	SAE "B" 4 Bolt, 4" Pilot Diameter
93	SAE "A" 2 Bolt, 3.25" Pilot Diameter
95	Pad Mount
96	SAE "B" 2 Bolt, 4" Pilot Diameter

BOX 5 REAR COVER - SIDE PORTS (PUMPS ONLY)				
PORTING			CODE	
TYPE	IN	OUT	CW	CCW
Blank	-	-	BI	IB
NPT Ports	1.25	1.00	AJ	JA
	1.25	0.75	AK	KA
	1.00	1.00	AL	LA
	1.00	0.75	AM	MA
	0.75	0.75	AR	RA
Split Flange Ports	1.00	0.75	EJ	JE
	1.00	0.50	EK	KE
	0.75	0.75	EL	LE
	0.75	0.50	EM	ME
	1.00	-	OE	EO
	0.75	-	OF	FO
	-	0.75	OJ	JO
	-	0.50	OL	LO

BOX 5 REAR COVER - SIDE PORTS (PUMPS ONLY)				
PORTING			CODE	
TYPE	IN	OUT	CW	CCW
SAE PORTS	1.25	1.00	FB	BF
	1.25	0.875	FC	CF
	1.25	0.75	FG	GF
	1.25	0.625	FJ	JF
	1.00	1.00	FL	LF
	1.00	0.875	FV	VF
	1.00	0.75	FW	WF
	1.00	0.625	FX	XF
	0.875	0.875	FY	YF
	0.875	0.75	FZ	ZF
	0.875	0.625	BC	CB
	0.875	0.50	BG	GB
	0.75	0.75	BJ	JB
	0.75	0.625	BL	LB
	0.75	0.50	BN	NB
	1.25	-	BV	VB
	1.00	-	BW	WB
	0.875	-	BX	XB
	0.75	-	BY	YB
	-	1.00	BZ	ZB
-	0.875	PD	DP	
-	0.75	PE	EP	
-	0.625	PM	MP	
-	0.50	PN	NP	

BOX 5 REAR COVER - SIDE PORTS (MOTORS ONLY)			
PORTING			CODE
TYPE	IN	OUT	BI-ROTATION
NPT Ports	1.00	1.00	DM
	0.75	0.75	DN
	0.50	0.50	DQ
Split Flange Ports	1.00	1.00	DR
	0.75	0.75	DS
SAE PORTS	1.00	1.00	VN
	0.75	0.75	VR
	0.50	0.50	VQ



Z32 MODEL NUMBER CONSTRUCTION

BOX 5 REAR COVER - REAR PORTS (PUMPS ONLY)				
PORTING			CODE	
TYPE	IN	OUT	CW	CCW
SAE Ports	1.25	1.00	UC	CU
	1.25	0.875	UF	FU
	1.25	0.75	UN	NU
	1.00	1.00	UD	DU
	1.00	0.875	UP	PU
	1.00	0.75	UQ	QU
	1.00	0.625	UR	RU
	0.875	0.875	LN	NL
	0.875	0.75	LP	PL
	0.875	0.625	LQ	QL
	0.75	0.75	LR	RL
	0.75	0.625	LS	SL
	0.75	0.50	LT	TL

BOX 5 REAR COVER - REAR PORTS (MOTORS ONLY)			
PORTING			CODE
TYPE	IN	OUT	BI-ROTATION
NPT Ports	1.00	1.00	RX
	0.75	0.75	RY
	0.50	0.50	RZ
SAE PORTS	1.00	1.00	RN
	0.75	0.75	RQ
	0.50	0.50	RS

BOX 6 GEAR HOUSING	
CODE	STYLE
AB	Pump
EB	Motor

BOX 7 GEAR WIDTH				
CODE	GEAR WIDTH	IN ³ /REV	CM ³ /REV	MAX PRESSURE
03	0.375	0.47	7.6	3500PSI (241BAR)
05	0.50	0.62	10.2	3500PSI (241BAR)
06	0.625	0.78	12.7	3500PSI (241BAR)
07	0.75	0.93	15.2	3500PSI (241BAR)
08	0.875	1.09	17.8	3500PSI (241BAR)
10	1.00	1.24	20.3	3500PSI (241BAR)
11	1.125	1.40	22.9	3500PSI (241BAR)
12	1.25	1.55	25.4	3500PSI (241BAR)
13	1.375	1.71	27.9	3500PSI (241BAR)
15	1.50	1.86	30.5	3300PSI (228BAR)
16	1.625	2.02	33.0	3100PSI (214BAR)
17	1.75	2.17	35.6	2900PSI (200BAR)
18	1.875	2.33	38.1	2700PSI (186BAR)
20	2.00	2.48	40.6	2500PSI (172BAR)

BOX 8 SHAFT TYPE	
CODE	DESCRIPTION
97	SAE "A" Key, 5/8 Dia Round Shaft
96	SAE "A" 5/8 - 9T Spline
66	SAE "B" Key, 7/8 Dia Round Shaft
65	SAE "B" 7/8 - 13T Spline

BOX 9 BEARING CARRIERS, PUMP ONLY 1 INLET, 1 OUTLET (OUTLET FOR FRONT HOUSING)				
PORTING			CODE	
TYPE	INLET	OUTLET	CW	CCW
Split Flange Ports	1.25	1.25	CJ	JC
	1.25	1.00	CL	LC
	1.25	0.75	CM	MC
	1.25	0.50	HB	BH
	1.00	1.00	HC	CH
	1.00	0.75	HF	FH
	1.00	0.50	HL	LH
	0.75	0.75	HM	MH
	0.75	0.50	HN	NH
	SAE Ports	1.50	1.50	KB
1.50		1.25	KC	CK
1.50		1.00	KF	FK
1.50		0.875	KL	LK
1.50		0.75	KM	MK
1.25		1.25	KN	NK
1.25		1.00	KO	OK
1.25		0.875	KP	PK
1.25		0.75	KQ	QK
1.25		0.625	MB	BM
1.25		0.50	ML	LM
1.00		1.00	MN	NM
1.00		0.875	MQ	QM
1.00		0.75	MR	RM
1.00		0.625	MS	SM
1.00		0.50	MT	TM
0.75		0.75	MU	UM
0.75		0.625	MV	VM
0.75	0.50	MW	WM	



Z32 MODEL NUMBER CONSTRUCTION

BOX 9		BEARING CARRIERS, PUMP ONLY 1 INLET, 2 OUTLETS			
PORTING				CODE	
TYPE	INLET PORT	OUTLET PORTS		CW	CCW
		Top = CW Bot. =CCW	Top = CCW Bot. =CW		
Split Flange Ports	1.25	0.75	0.75	CA	AC
	1.25	0.75	0.50	DA	AD
	1.25	0.50	0.50	EA	AE
	1.00	0.75	0.75	FA	AF
	1.00	0.75	0.50	GA	AG
	1.00	0.50	0.50	HA	AH
SAE Ports	1.50	1.00	1.00	JG	GJ
	1.50	1.00	0.875	KG	GK
	1.50	0.875	0.875	LG	GL
	1.50	1.00	0.75	MG	GM
	1.50	0.75	0.75	NG	GN
	1.25	1.00	1.00	PG	GP
	1.25	1.00	0.875	QG	GQ
	1.25	0.875	0.875	RG	GR
	1.25	1.00	0.75	SG	GS
	1.25	0.75	0.75	TG	GT
	1.25	0.75	0.625	UG	GU
	1.25	0.75	0.50	VG	GV
	1.25	0.625	0.625	WG	GW
	1.25	0.50	0.50	XG	GX
	1.00	1.00	1.00	YG	GY
	1.00	1.00	0.875	ZG	GZ
	1.00	0.875	0.875	RC	CR
	1.00	1.00	0.75	SC	CS
	1.00	0.75	0.75	TC	CT
	1.00	0.75	0.625	VC	CV
1.00	0.75	0.50	WC	CW	
1.00	0.625	0.625	XC	CX	
1.00	0.50	0.50	YC	CY	

Z32 FLOW DIAGRAM

Single Unit Flow Diagram (CW Rotation)

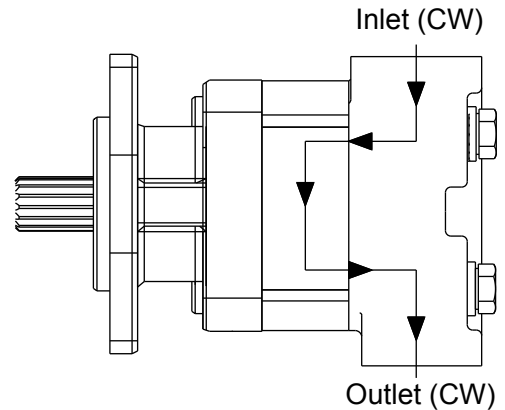

Tandem Unit Flow Diagram (CW Rotation)
1 Inlet, 2 Outlet Style Bearing carrier shown

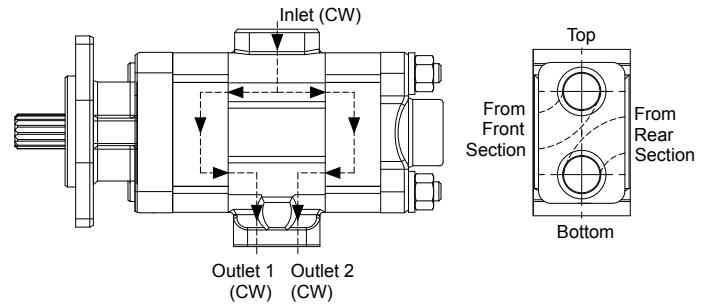

UNIT ROTATION

To determine rotation of a unit, position unit with shaft facing you, "belly" down (ref. image below). A clockwise unit will flow left (inlet) to right (outlet). A counter-clockwise unit will flow from right (inlet) to left (outlet).

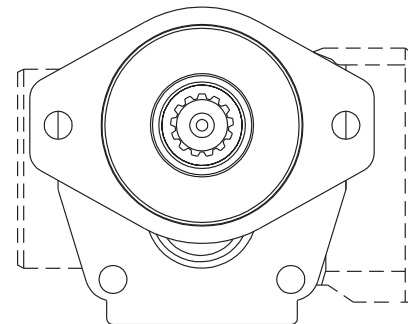
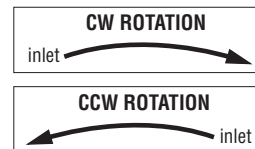

BOX 9		BEARING CARRIERS (COMMON INLET PASSAGE) NO PORTS		
PORTING			CODE	
TYPE	INLET	OUTLET	CW	CCW
NO Ports	-	-	C	D

BOX 10		CONNECTING SHAFT (MULTIPLE UNITS ONLY)
CODE	DESCRIPTION	
1	Connecting Shaft	



Z32 PUMP/MOTOR DIMENSIONS (REF. ONLY)

SINGLE UNIT

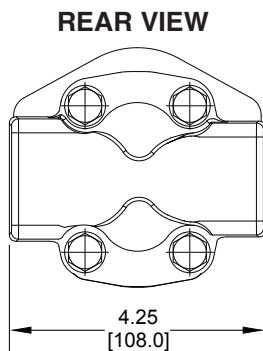
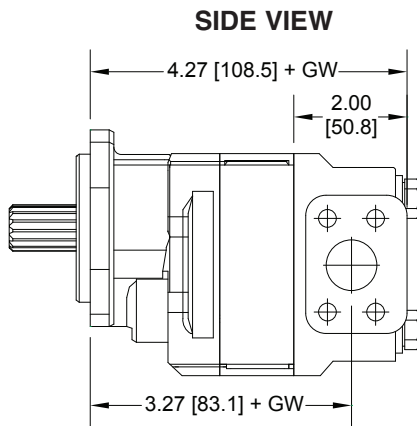
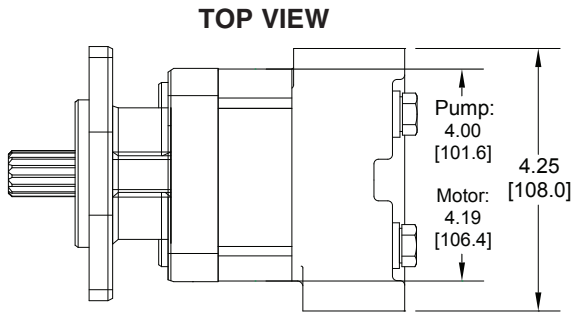

TANDEM UNIT

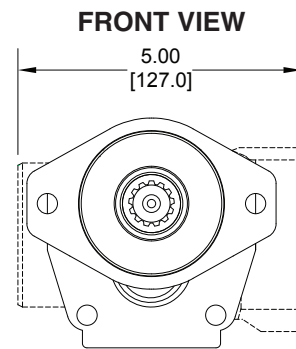
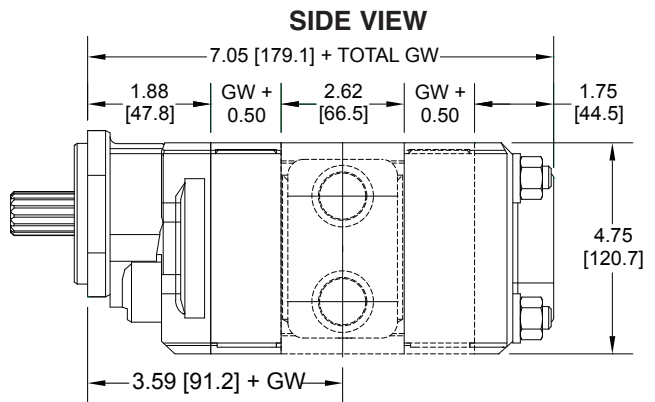
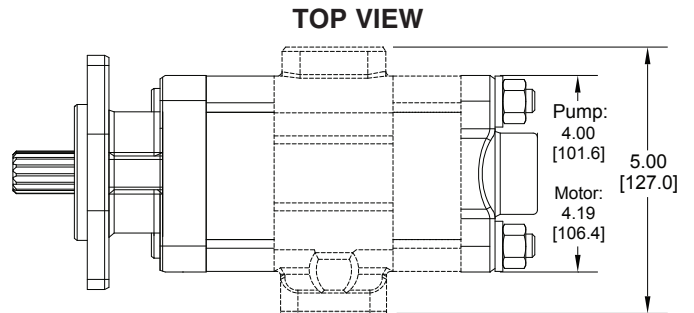

Dimensional Notes

- GW = Gear Width
- Dashed lines represent tandem addition, delete for single unit.
- Z32 Bolt Diameter: 1/2" - 13 UNC
- Thrust Plate Thickness: 0.250" each (2 required per gear housing)
- Doweled construction is standard

GENERAL INFORMATION

“Z” Product General Information (Applies to all series unless noted)

OIL RECOMMENDATIONS

Muncie Power Products does not promote specific manufacturer's brands of oil, but does recommend the use of quality petroleum based hydraulic fluids. Different climate temperatures require that the oil viscosity be appropriate for the operating conditions. Consult the oil manufacturer for your exact application needs. (Note: NEVER dilute the hydraulic fluid for cold weather operation with, including but not limited to, diesel fuel, kerosene, etc.)

- Oil Viscosity: 60-1000 SSU (10.5-216 cST) for continuous operation. Viscosity should not exceed 7500 SSU (1600 cST) MAX at startup.
- Special Fluids: Biodegradable and water-glycol type fluids are ok for use with bushing design ONLY, NOT roller bearing type products.

INLET / OUTLET CONDITION

- Maximum inlet vacuum should not exceed 5 in.Hg. across all operating RPM's and temperature conditions.
- An undersized inlet port size could have maximum RPM limitations.
- An oversized outlet port size could have maximum pressure limitations.

OPERATING TEMPERATURES

Proper control of the system operating temperature is critical for long product life and the protection of all other hydraulic components as well.

- Optimum operating temperatures: 100-140°F (37.8-60°C)
- MAX Continuous temperature: 180°F (82°C)
- MAX Intermittent temperature: 200°F (93°C)

HOSE SIZING

Hydraulic hose must be properly sized based on the oil velocity in feet per second (FPS) and of the appropriate type (SAE rating) for the specified rate of flow and pressure. The following are hose recommendations for common applications; hose requirements may differ for non-standard applications.

- Inlet hose: 2-4 FPS, SAE 100R4 type
- Pressure hose: 7-15 FPS, SAE 100R2 type
- Return hose: 4-8 FPS, SAE 100R1 type

FILTRATION

Proper filtration is vital to the life of any hydraulic system, as it helps protect hydraulic components from foreign objects which may have entered the system.

- **Return Line Filters:** Return filters are always recommended with a minimum 10 micron rating. Some applications require better filtration with an absolute rating and possibly 3 or 6 micron media.
- **Pressure Filters:** Pressure filter are not typically required for gear pump applications, but they are available if desired.
- **Suction Strainers:** Suction strainers are very useful in catching large objects. Strainers should never be sized smaller than 100 mesh (149 micron), and should always include a 3 PSI (0.2 BAR) bypass.

STARTUP OF A NEW OR RE-BUILT PUMP

Before startup of a new or re-built pump, the installer should always do the following:

- Properly install the pump and all other necessary components
- Fill the pump ports with clean oil
- Back off the main relief valve, or have complete confidence that it is set correctly
- Connect all lines for proper operation
- Engage the pump and allow to run under a no load condition at engine idle for 2 minutes
- If ok, increase engine to normal operating RPM and allow to run for another 2 minutes
- If no problems are detected, reset (if needed) the main relief valve to its proper setting with engine at operating RPM.
- Bushing pumps require a “Power & Flush” startup procedure *
- Bushing motors must be broken in before installation*

* Reference document no. R3007 for details.

SHAFT TORQUE LIMITATION

The pump input shaft can withstand torques up to the designed shaft torque limitation (STL). This figure is based on multiplying the pump cubic inch displacement x the pump pressure (i.e.: $D \times P \leq STL$). Tandem pumps are two pumps with individual calculated STLs added together not do exceed limitation figures.

Z32 SERIES (REF. 315)

SHAFT STYLE	INTEGRAL SHAFT & GEAR	TWO-PIECE STYLE
SAE “A” Spline, 5/8 9T	5528	--
SAE “A” Key, 5/8” dia.	4472	--
SAE “B” Spline, 7/8 13T	16646	--
SAE “B” Key, 7/8” dia.	12298	--
Connecting Shaft	--	6894



ONE-YEAR PUMP/MOTOR WARRANTY

The Muncie Cast Iron Pump/Motor “Z Product Group” is warranted against any defect in material and workmanship which existed at the time of sale by Muncie Power Products, according to the following provisions, subject to the requirements that the pump/motor must be used only in accordance with catalog and package instructions.

The pump/motor is warranted for a period of one year from the date of installation. If during the warranty period the pump/motor fails to operate to Muncie’s specifications due to a defect in any part in material or workmanship that existed at the time of sale by Muncie Power Products, the defective part will be repaired or replaced, at Muncie’s election, at no charge, if the defective part is returned to Muncie with the transportation prepaid.

WARNING: The above warranty shall terminate if any alterations or repairs are made to the pump/motor other than at Muncie Power Products, or if the pump is used on any equipment other than the equipment upon which it is first installed.

THE FOREGOING WARRANTIES ARE IN LIEU OF ALL OTHER OBLIGATIONS AND LIABILITIES, INCLUDING NEGLIGENCE AND ALL WARRANTIES OF MERCHANTABILITY AND SUITABILITY, EXPRESSED OR IMPLIED, AND STATE MUNCIE’S ENTIRE AND EXCLUSIVE LIABILITY AND BUYER’S EXCLUSIVE REMEDY FOR ANY CLAIM OF DAMAGES IN CONNECTION WITH THE SALE, REPAIR OF REPLACEMENT OF THE ABOVE GOODS, THEIR DESIGN, INSTALLATION OR OPERATION. MUNCIE WILL IN NO EVENT BE LIABLE FOR ANY DIRECT, INDIRECT, SPECIAL, INCIDENTAL OR CONSEQUENTIAL DAMAGES WHATSOEVER, AND OUR LIABILITY UNDER NO CIRCUMSTANCES WILL EXCEED THE CONTRACT PRICE FOR THE GOODS FOR WHICH LIABILITY IS CLAIMED.

Distributed by:

