

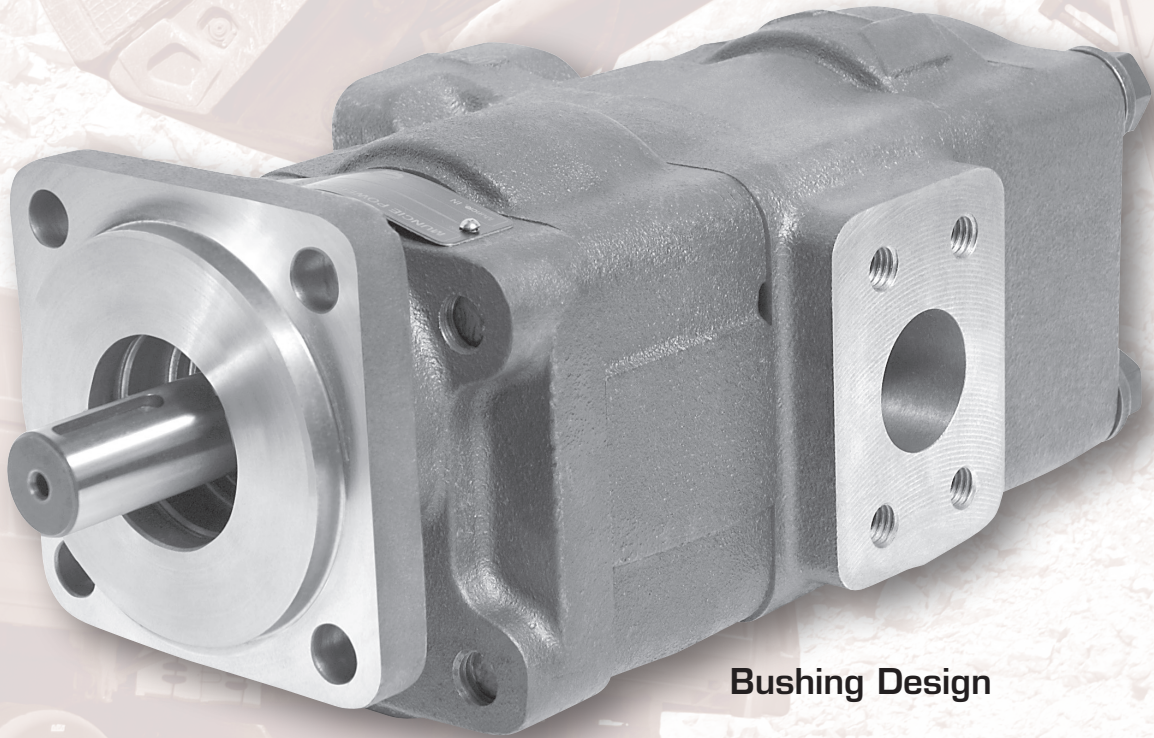

Z SERIES

Hydraulic Pump/Motor Product Group

Z34 Technical Specifications



Bushing Design

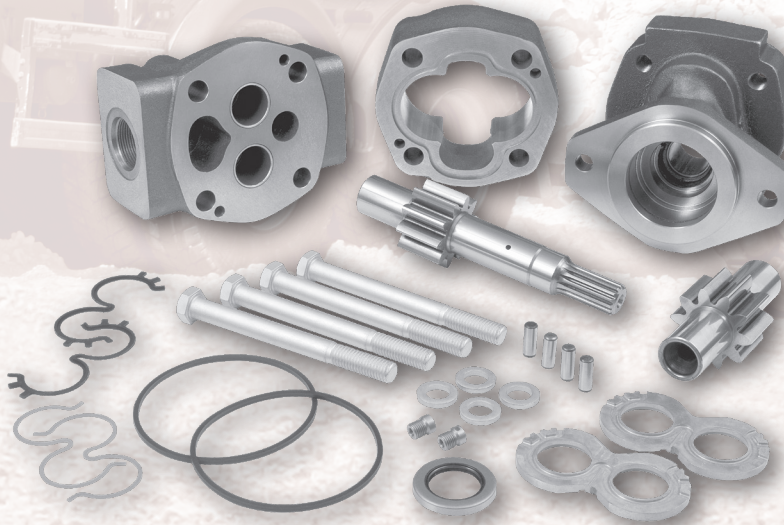

Replacement parts for industry common pump/motor series. Assemblies are built to match your replacement or to meet new installation requirements.

Z34 TECHNICAL SPECIFICATIONS

Muncie Power Product's "Z" series gear pump/motor assemblies are custom built to your replacement or new installation requirements. The Z34 series offers numerous shaft, flange and port arrangement options to fit a wide variety of application needs. Rigid one-piece drive shafts and pressure balancing wear plates provide top efficiency, while high strength cast iron housings provide durability for the toughest environment.

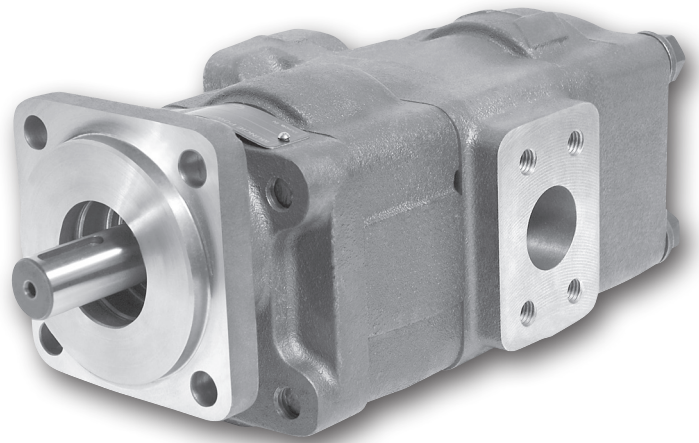

Flows up to 51 GPM, Pressures up to 3500 PSI, Speeds to 3000 RPM, Bushing Design

Muncie Power Products has served the mobile application industry for more than 75 years. We strive to provide the highest quality products and support. Call today and let us give you the power to your hydraulic system.

APPLICATIONS

Construction • Mining • Forestry • Truck • Agriculture • Marine • Material Handling

SPECIFICATION	GEAR WIDTH						
	0.50	0.75	1.00	1.25	1.50	1.75	2.00
Housing Width, in	1.00	1.25	1.5	1.75	2.00	2.25	2.50
Displacement, in ³ (cc)	0.99 (16.1)	1.48 (24.2)	1.97 (32.3)	2.46 (40.4)	2.96 (48.4)	3.45 (56.5)	3.94 (64.6)
GPMt (LPM) @ 1000 RPM	4.3 (16.1)	6.4 (24.2)	8.5 (32.3)	10.6 (40.4)	12.8 (48.4)	14.9 (56.5)	17.1 (64.6)
Min. RPM	900	900	900	900	900	900	900
Max. RPM	3000	3000	3000	3000	3000	3000	3000
Max. Pres., PSI (BAR)	3500 (241)	3500 (241)	3500 (241)	3500 (241)	3500 (241)	3250 (224)	3000 (207)
Approx. Wt., lbs. (Kg) - Single Unit	33.5 (15.2)	34.75 (15.8)	36.0 (16.3)	37.25 (16.9)	38.5 (17.5)	39.75 (18.0)	41.0 (18.6)
Approx. Wt., lbs. (Kg) - Multiple Unit*	33.5 (15.2)	34.75 (15.8)	36.0 (16.3)	37.25 (16.9)	38.5 (17.5)	39.75 (18.0)	41.0 (18.6)
Motor Data: Motor torque and HP values shown below are based on 1000 RPM per 1000 PSI, no efficiency values are in the calculations for GPMt. Maximum pressure ratings are the same as above.							
Motor Input, GPMt (LPM) @ 1000 RPM	4.3 (16.1)	6.4 (24.2)	8.5 (32.3)	10.6(40.4)	12.8 (48.4)	14.9 (56.5)	17.1 (64.6)
Motor Output Torq, in-lbs @ 1000 RPM	158.1	235.3	312.5	389.8	470.7	547.9	628.8
Motor Output HP @ 1000 PSI	2.5	3.7	5.0	6.2	7.5	8.7	10.0
Motor Min. RPM	900	900	900	900	900	900	900
Motor Max. RPM	3000	3000	3000	3000	3000	3000	3000

*Add specified weight per each additional single section

PRODUCT FEATURES

- 7 pump sizes available with flows between 4.3-17.1 GPM (16.1-64.6 LPM) @ 1000 RPM
- High grade cast iron construction for durability and high performance product requirements
- Up to 3500 PSI (241 BAR) capability to hold up in the toughest environments.
- Heavy duty, low friction bushing design can withstand severe applications and provide long product life
- SAE & Split Flange porting is available
- Multiple shaft and flange options available to fit your application needs

SERIES DESCRIPTION

Muncie's Z34 series offers larger pump sizes and greater flows when compared to the Z32 series. The Z34 is great for harsh, intermediate applications and offers a variety of pump configurations to fit several different applications across many industries. Heavy duty bushing design makes for superior performance and reliability in the most extreme hydraulic applications. Strength, high efficiency and high endurance give the Z34 series long life capabilities for the toughest operating conditions. Muncie's Z34 series is similar to Parker's 330 series and Permco's 197 series.



Z34 MODEL NUMBER CONSTRUCTION

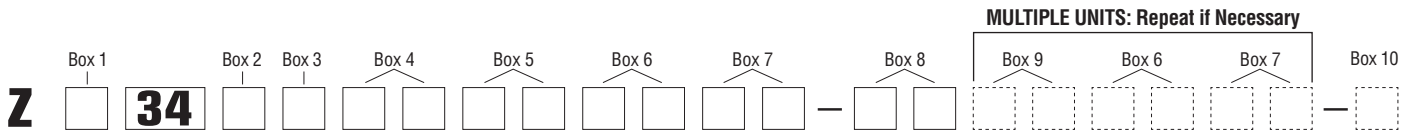

BOX 1 PUMP/MOTOR	
CODE	DESCRIPTION
P	Pump
M	Motor

BOX 2 UNIT CONFIGURATION	
CODE	DESCRIPTION
A	Single Unit
B	Tandem Unit (Extended Studs N/A)
C	Single or Tandem w/ 2 Piece Shaft (OB bearing required)
L	Unit with extended studs

BOX 3 UNIT TYPE & ROTATION	
CODE	DESCRIPTION
1	Pump, CW, w/o OB Bearing
2	Pump, CCW, w/o OB Bearing
4	Pump, CW, w/ OB Bearing
5	Pump, CCW, w/ OB Bearing
8	Motor, Bi-rotational, w/ OB Bearing, 1/4" SAE drain
9	Motor, Bi-rotational, w/o OB Bearing, 1/4" SAE drain

BOX 4 FRONT COVER FLANGE TYPE	
CODE	DESCRIPTION
42	SAE "B" 4 Bolt, 4" Pilot Diameter
78	SAE "C" 4 Bolt, 5" Pilot Diameter
97	SAE "B" 2 Bolt, 4" Pilot Diameter

BOX 5 REAR COVER - SIDE PORTS (PUMPS ONLY)				
PORTING			CODE	
TYPE	IN	OUT	CW	CCW
Blank	-	-	BI	IB
Split Flange Ports	1.5	1.25	EJ	JE
	1.5	1.0	EK	KE
	1.25	1.25	EL	LE
	1.25	1.0	EM	ME
	1.0	1.0	EN	NE
	1.5	-	OF	FO
	1.25	-	OG	GO
	1.0	-	OJ	JO
SAE Ports	-	1.25	OM	MO
	-	1.0	ON	NO
	1.25	1.0	FJ	JF
	1.0	1.0	FL	LF
	1.25	-	BG	GB
	1.0	-	BJ	JB
-	1.0	BN	NB	

BOX 5 REAR COVER - SIDE PORTS (MOTORS ONLY)			
PORTING			CODE
TYPE	IN	OUT	BI-ROTATION
Blank	-	-	BA
Split Flange Ports	1.25	1.25	CS
	1.0	1.0	CT
	0.75	0.75	CV
SAE PORTS	1.25	1.25	VC
	1.0	1.0	VN
	0.75	0.75	VR

BOX 6 GEAR HOUSING	
CODE	STYLE
AB	Pump
EB	Motor



Z34 MODEL NUMBER CONSTRUCTION

BOX 7		GEAR WIDTH		
CODE	GEAR WIDTH	IN ³ /REV	CM ³ /REV	MAX PRESSURE
05	0.50	0.99	16.1	3500PSI (241BAR)
07	0.75	1.48	24.2	3500PSI (241BAR)
10	1.00	1.97	32.3	3500PSI (241BAR)
12	1.25	2.46	40.4	3500PSI (241BAR)
15	1.50	2.96	48.4	3500PSI (241BAR)
17	1.75	3.45	56.5	3250PSI (224BAR)
20	2.00	3.94	64.6	3000PSI (207BAR)

BOX 8		SHAFT TYPE
CODE	DESCRIPTION	
07	SAE "C" 1.25" 14T Spline*	
25	SAE "B" 0.875" 13T Spline	
30	SAE "B" Keyed, 0.875" Dia., 0.25" Key	
43	SAE "BB" Keyed, 1.0" Dia., 0.25" Key	
98	SAE "BB" 1.0" 15T Spline	

* Available as two piece shaft style only

BOX 9		BEARING CARRIERS, PUMP ONLY 1 INLET, 2 OUTLETS			
PORTING			CODE		
TYPE	INLET PORT	OUTLET PORTS		CW	CCW
		Top = CW Bot. = CCW	Top = CCW Bot. = CW		
Split Flange Ports	2.0	1.25	1.25	AM	MA
	2.0	1.25	1.0	AN	NA
	2.0	1.0	1.0	AP	PA
	1.5	1.25	1.25	AT	TA
	1.5	1.25	1.0	AU	UA
	1.5	1.0	1.0	AV	VA
	1.25	1.25	1.25	AW	WA
	1.25	1.25	1.0	AX	XA
	1.25	1.0	1.0	AY	YA
	1.0	1.0	1.0	AZ	ZA
SAE Ports	1.5	1.0	1.0	GV	VG
	1.25	1.0	1.0	GY	YG
	1.0	1.0	1.0	GZ	ZG

BOX 9		BEARING CARRIERS, PUMP ONLY 1 INLET, 1 OUTLET (OUTLET FOR FRONT HOUSING)		
PORTING			CODE	
TYPE	INLET	OUTLET	CW	CCW
Split Flange Ports	2.0	1.5	HB	BH
	2.0	1.25	HC	CH
	2.0	1.0	HF	FH
	1.5	1.5	HL	LH
	1.5	1.25	HM	MH
	1.5	1.0	HN	NH
	1.25	1.25	HO	OH
	1.25	1.0	HP	PH
	1.0	1.0	HQ	QH
SAE Ports	1.25	1.0	RS ¹	SR ¹
	1.5	1.25	KM	MK
	1.5	1.0	KN	NK
	1.25	1.25	KO	OK
	1.25	1.0	KP	PK
	1.0	1.0	KQ	QK

1 - Outlet port for rear section

BOX 9		BEARING CARRIERS, PUMP ONLY 1 INLET, 1 OUTLET (COMBINED OUTLET)		
PORTING			CODE	
TYPE	INLET	OUTLET	CW	CCW
Split Flange Ports	2.0	1.5	UN	NU
	2.0	1.25	UO	OU
	1.5	1.5	UP	PU
	1.5	1.25	UQ	QU
	1.25	1.25	UR	RU
	SAE Ports	1.5	1.25	PQ
1.25		1.25	PR	RP



Z34 MODEL NUMBER CONSTRUCTION

BOX 9 BEARING CARRIERS, MOTORS ONLY			
1 INLET, 1 OUTLET (COMBINED OUTLET)			
PORTING			CODE
TYPE	INLET	OUTLET	BI-ROTATION
Split Flange Ports	1.5	1.5	BB
	1.25	1.25	CC
	1.0	1.0	EE
	0.75	0.75	FF
SAE Ports	1.25	1.25	NN
	1.0	1.0	QQ
	0.75	0.75	RR

BOX 9 BEARING CARRIERS (COMMON INLET PASSAGE)				
NO PORTS				
PORTING			CODE	
TYPE	INLET	OUTLET	CW	CCW
NO Ports	-	-	C	D

BOX 10 CONNECTING SHAFT (MULTIPLE UNITS ONLY)	
CODE	DESCRIPTION
1	Connecting Shaft

TYPICAL FLOW DIAGRAMS

Will vary depending on port location

Single Unit Flow Diagram (CW Rotation)

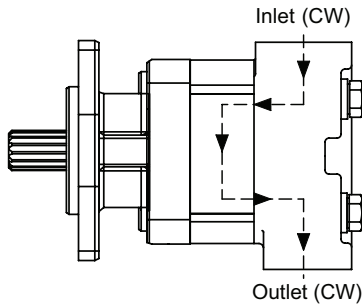

Tandem Unit Flow Diagram (CW Rotation)

1 Inlet, 2 Outlet Style (Bearing carrier shown)

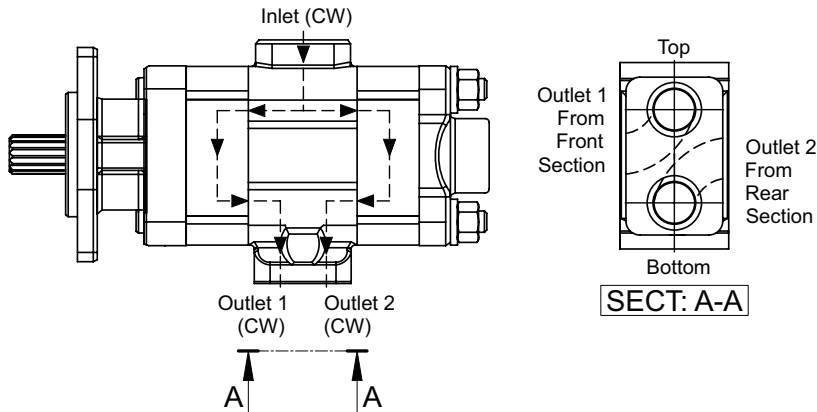

UNIT ROTATION

To determine rotation of a unit, position unit with shaft facing you, "belly" down (ref. image below). A clockwise unit will flow left (inlet) to right (outlet). A counter-clockwise unit will flow from right (inlet) to left (outlet).

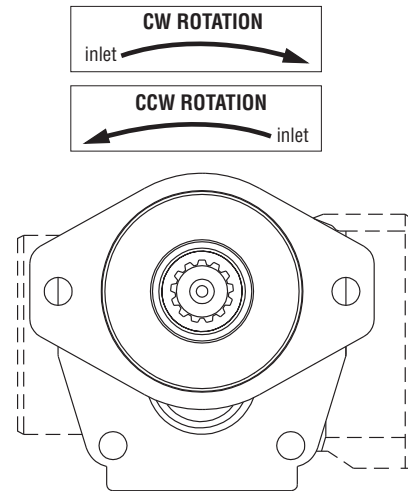

Z34 PUMP/MOTOR DIMENSIONS (REF. ONLY)

SINGLE UNIT

SIDE VIEW

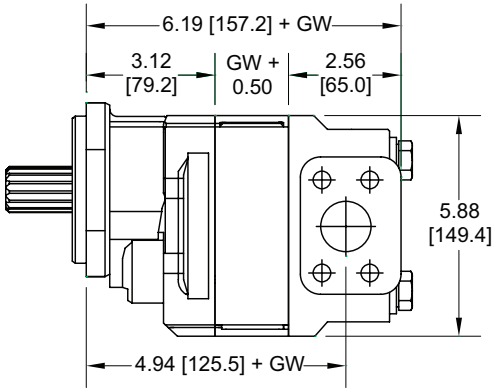

TOP VIEW

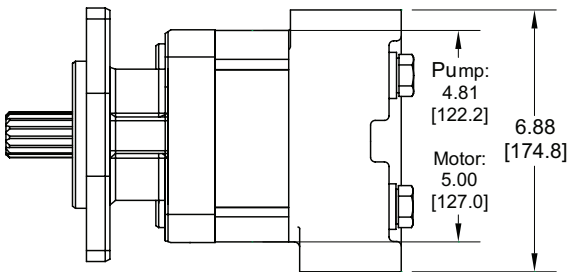

REAR VIEW

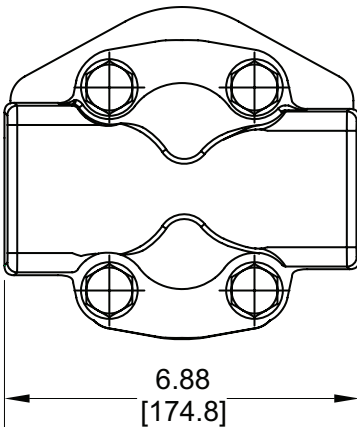

TANDEM UNIT

SIDE VIEW

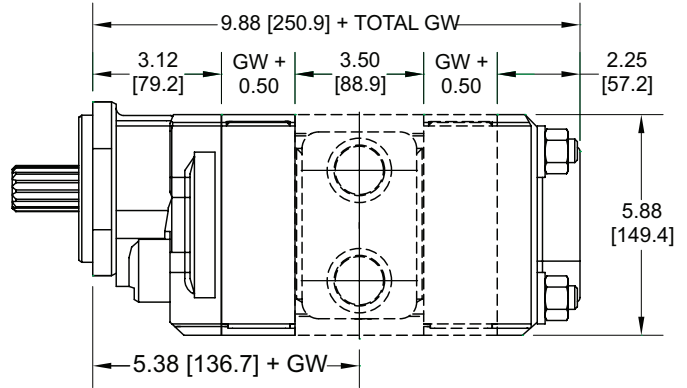

TOP VIEW

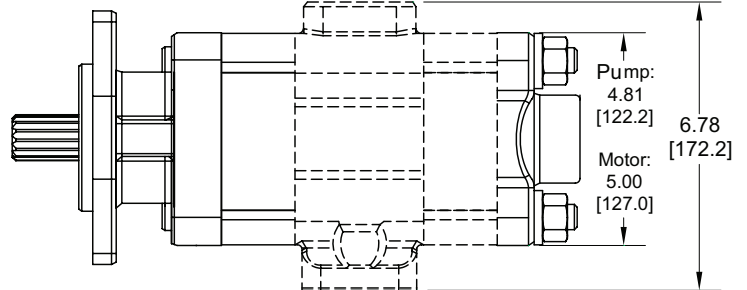

FRONT VIEW

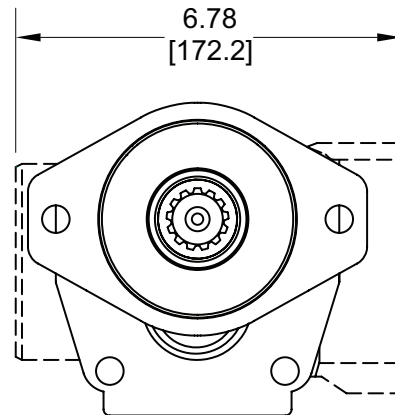

Dimensional Notes

- GW = Gear Width
- Dashed lines represent tandem addition, delete for single unit.
- Rear cover and bearing carrier widths will vary with port type.
- Z34 Bolt Diameter: 5/8" - 11 UNC
- Thrust Plate Thickness: 0.250" each (2 required per gear housing).
- Doweled construction is standard.



GENERAL INFORMATION

“Z” Product General Information (Applies to all series unless noted)

OIL RECOMMENDATIONS

Muncie Power Products does not promote specific manufacturer's brands of oil, but does recommend the use of quality petroleum based hydraulic fluids. Different climate temperatures require that the oil viscosity be appropriate for the operating conditions. Consult the oil manufacturer for your exact application needs. (Note: NEVER dilute the hydraulic fluid for cold weather operation with, including but not limited to, diesel fuel, kerosene, etc.)

- Oil Viscosity: 60-1000 SSU (10.5-216 cST) for continuous operation. Viscosity should not exceed 7500 SSU (1600 cST) MAX at startup.
- Special Fluids: Biodegradable and water-glycol type fluids are ok for use with bushing design ONLY, NOT roller bearing type products.

INLET / OUTLET CONDITION

- Maximum inlet vacuum should not exceed 5 in.Hg. across all operating RPM's and temperature conditions.
- An undersized inlet port size could have maximum RPM limitations.
- An oversized outlet port size could have maximum pressure limitations.

OPERATING TEMPERATURES

Proper control of the system operating temperature is critical for long product life and the protection of all other hydraulic components as well.

- Optimum operating temperatures: 100-140°F (37.8-60°C)
- MAX Continuous temperature: 180°F (82°C)
- MAX Intermittent temperature: 200°F (93°C)

HOSE SIZING

Hydraulic hose must be properly sized based on the oil velocity in feet per second (FPS) and of the appropriate type (SAE rating) for the specified rate of flow and pressure. The following are hose recommendations for common applications; hose requirements may differ for non-standard applications.

- Inlet hose: 2-4 FPS, SAE 100R4 type
- Pressure hose: 7-15 FPS, SAE 100R2 type
- Return hose: 4-8 FPS, SAE 100R1 type

FILTRATION

Proper filtration is vital to the life of any hydraulic system, as it helps protect hydraulic components from foreign objects which may have entered the system.

- **Return Line Filters:** Return filters are always recommended with a minimum 10 micron rating. Some applications require better filtration with an absolute rating and possibly 3 or 6 micron media.
- **Pressure Filters:** Pressure filter are not typically required for gear pump applications, but they are available if desired.
- **Suction Strainers:** Suction strainers are very useful in catching large objects. Strainers should never be sized smaller than 100 mesh (149 micron), and should always include a 3 PSI (0.2 BAR) bypass.

STARTUP OF A NEW OR RE-BUILT PUMP

Before startup of a new or re-built pump, the installer should always do the following:

- Properly install the pump and all other necessary components
- Fill the pump ports with clean oil
- Back off the main relief valve, or have complete confidence that it is set correctly
- Connect all lines for proper operation
- Engage the pump and allow to run under a no load condition at engine idle for 2 minutes
- If ok, increase engine to normal operating RPM and allow to run for another 2 minutes
- If no problems are detected, reset (if needed) the main relief valve to its proper setting with engine at operating RPM.
- Bushing pumps require a “Power & Flush” startup procedure *
- Bushing motors must be broken in before installation*

* Reference document no. R3007 for details.

SHAFT TORQUE LIMITATION

The pump input shaft can withstand torques up to the designed shaft torque limitation (STL). This figure is based on multiplying the pump cubic inch displacement x the pump pressure (i.e.: $D \times P \leq STL$). Tandem pumps are two pumps with individual calculated STLs added together not do exceed limitation figures.

Z34 SERIES (REF. 330)

SHAFT STYLE	INTEGRAL SHAFT & GEAR	TWO-PIECE STYLE
SAE “B” Spline, 7/8” 13T	16569	12255
SAE “B” Key, 7/8” dia.	12255	12255
SAE “BB” Spline, 1” 15T	25490	12255
SAE “B” Key, 1” dia	18235	12255
SAE “C” Spline, 1.25” 14T	--	12255
Connecting Shaft	--	12255



ONE-YEAR PUMP/MOTOR WARRANTY

The Muncie Cast Iron Pump/Motor “Z Product Group” is warranted against any defect in material and workmanship which existed at the time of sale by Muncie Power Products, according to the following provisions, subject to the requirements that the pump/motor must be used only in accordance with catalog and package instructions.

The pump/motor is warranted for a period of one year from the date of installation. If during the warranty period the pump/motor fails to operate to Muncie’s specifications due to a defect in any part in material or workmanship that existed at the time of sale by Muncie Power Products, the defective part will be repaired or replaced, at Muncie’s election, at no charge, if the defective part is returned to Muncie with the transportation prepaid.

WARNING: The above warranty shall terminate if any alterations or repairs are made to the pump/motor other than at Muncie Power Products, or if the pump is used on any equipment other than the equipment upon which it is first installed.

THE FOREGOING WARRANTIES ARE IN LIEU OF ALL OTHER OBLIGATIONS AND LIABILITIES, INCLUDING NEGLIGENCE AND ALL WARRANTIES OF MERCHANTABILITY AND SUITABILITY, EXPRESSED OR IMPLIED, AND STATE MUNCIE’S ENTIRE AND EXCLUSIVE LIABILITY AND BUYER’S EXCLUSIVE REMEDY FOR ANY CLAIM OF DAMAGES IN CONNECTION WITH THE SALE, REPAIR OF REPLACEMENT OF THE ABOVE GOODS, THEIR DESIGN, INSTALLATION OR OPERATION. MUNCIE WILL IN NO EVENT BE LIABLE FOR ANY DIRECT, INDIRECT, SPECIAL, INCIDENTAL OR CONSEQUENTIAL DAMAGES WHATSOEVER, AND OUR LIABILITY UNDER NO CIRCUMSTANCES WILL EXCEED THE CONTRACT PRICE FOR THE GOODS FOR WHICH LIABILITY IS CLAIMED.

Distributed by:

