



TRUNNION CYLINDERS

# TRUNNION CYLINDERS

SINGLE-ACTING TELESCOPIC



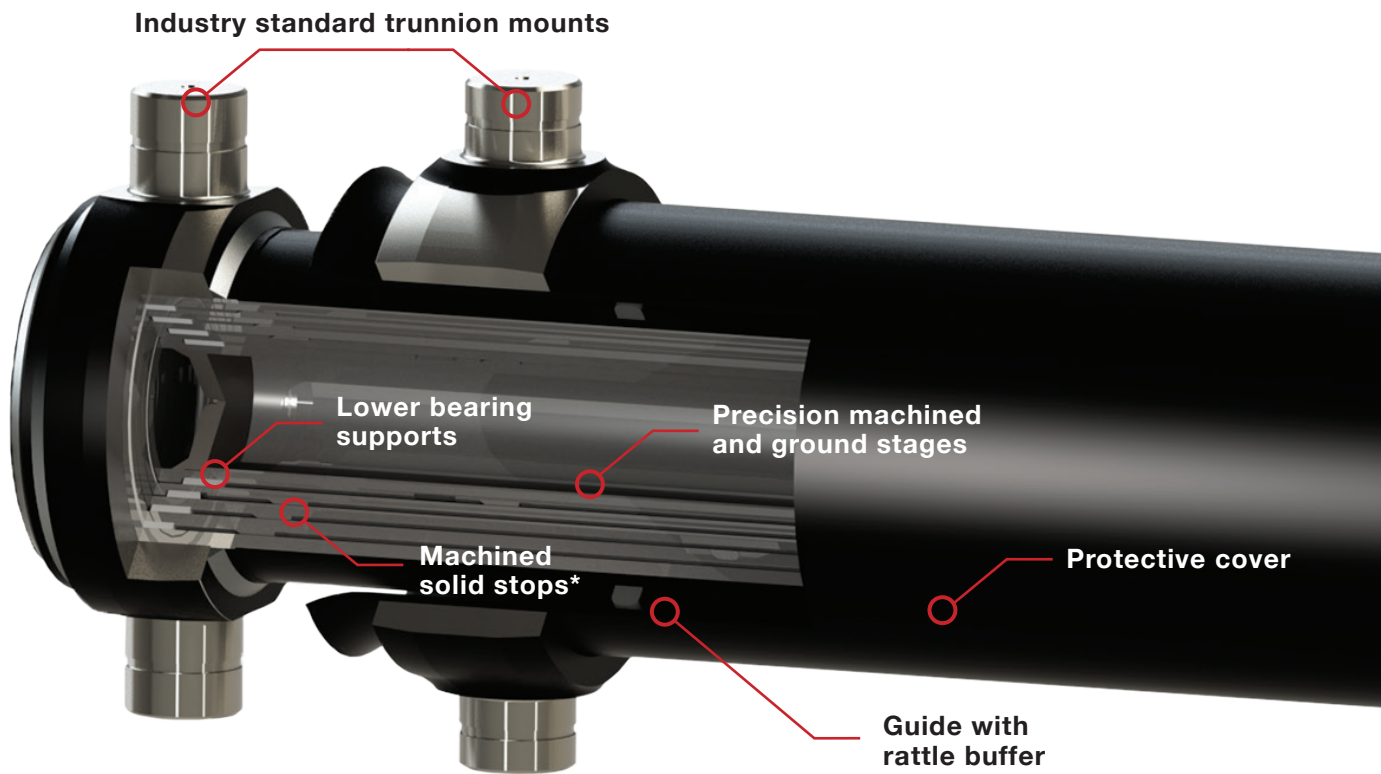

## CONSTRUCTION ELEMENTS

---

- Seamless one piece, high tensile tubes
- Solid machined end stops for each stage\*
- High column strength and stiffness
- Large bearing surface area due to increased overlap
- Robust / high durability design
- Self-bleeding design
- Tight tolerances and machining
- Small tube clearance for smaller bending moment
- Precision ground finish for optimum performance and seal life
- Easily removed outer cover for ease of service

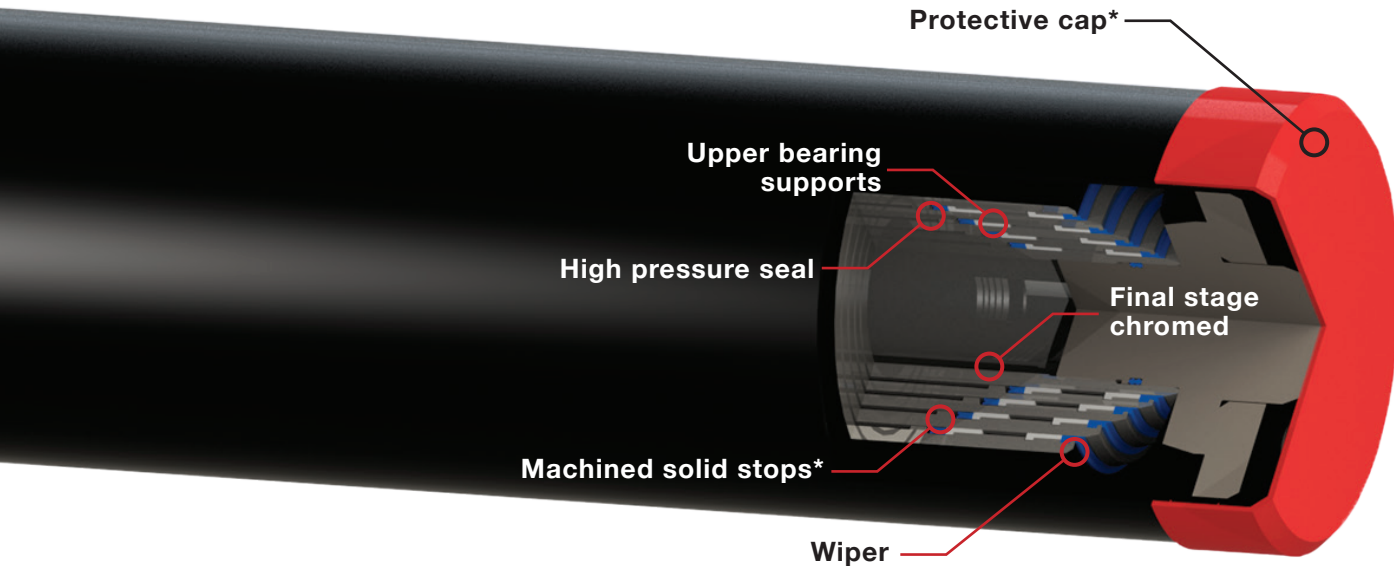

\* Feature not available on 3.5 and 4.5 series cylinders

## MODEL NUMBER CONSTRUCTION

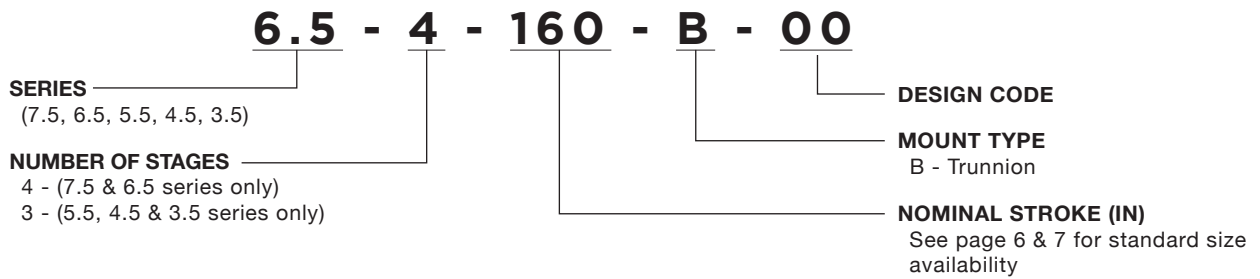

Muncie Trunnion Mount cylinders not only offer the mounting style that allows for increased capacity in the dump body by allowing for significant reduction or elimination of the dog house but also many other features. With the strict machining tolerances, solid stop contact faces\* and larger overlap between stages the Muncie cylinders are one of the strongest and most stable cylinders on the market.

## FEATURES & BENEFITS

<b>Material</b>	<ul style="list-style-type: none"> <li>• All Muncie cylinders are made of hot-rolled solid seamless tubes</li> <li>• Allow for higher pressures due to higher strength material, no weak points and Muncie's focus on quality</li> <li>• Increased resistance to mechanical stress and longer life</li> </ul>
<b>High-Precision Machining Process</b>	<ul style="list-style-type: none"> <li>• Solid stop faces are machined into each stage. This creates a single, solid component with no need for stop rings, bushings or gland nuts.*</li> </ul>
<b>Seals / Wipers</b>	<ul style="list-style-type: none"> <li>• Made of polyurethane, with a double-lip design, the seals and wipers assure optimum performance in all climate conditions (-40°F to 212°F / -40°C to 100°C)</li> <li>• Muncie cylinders do not require packing due to the top quality material which is paired with the precision machining of the stages</li> </ul>
<b>Sliders</b>	<ul style="list-style-type: none"> <li>• Made of DELRIN®, they are compatible with all types of hydraulic oils approved by pump makers and are capable of withstanding high and low pressures</li> <li>• Each cylinder is equipped with sliders at both the top and bottom of each stage</li> </ul>
<b>Overlap &amp; Column Stability</b>	<ul style="list-style-type: none"> <li>• Longer stages have greater overlap to improve column stability</li> </ul>
<b>Weight Savings</b>	<ul style="list-style-type: none"> <li>• Muncie's cylinder design offers one of the lightest solutions available on the market. This results in greater payloads, less oil consumption and faster dumping.</li> </ul>
<b>Low Maintenance</b>	<ul style="list-style-type: none"> <li>• Muncie cylinders have low maintenance requirements and offer many years of top performance without additional expenses</li> <li>• Self-bleeding design without stage packing nuts reduces time spent maintaining cylinder</li> <li>• Chrome-plated final stage extends the life of the cylinder</li> <li>• Easy assembly and disassembly process</li> <li>• Muncie cylinders are able to be reconditioned at low cost due to the solid machining, high-grade steel and dimensional stability of the cylinder during its work cycle</li> </ul>
<b>Two-Year Warranty</b>	<ul style="list-style-type: none"> <li>• Standard for Muncie cylinders.</li> </ul>

\* Feature not available on 3.5 and 4.5 series cylinders

# DUMP BODY CYLINDER CALCULATIONS

These calculations provide approximate values. Final calculations and product selection should be determined by a qualified engineer and engineering drawing.

When selecting a hydraulic cylinder for replacement. It is the responsibility of the purchaser and installer / user to verify that all dimensions, mounting, and performance features of the replacement cylinder are appropriate for the application.

- A = Dump hinge pin to center of load in inches**
- B = Dump hinge pin to cylinder base pin in inches**
- D = Dump body to frame angle**
- S = Stroke of cylinder**

\*Normal Minimum dump angle is 45°.  
Normal Maximum dump angle is 57°.

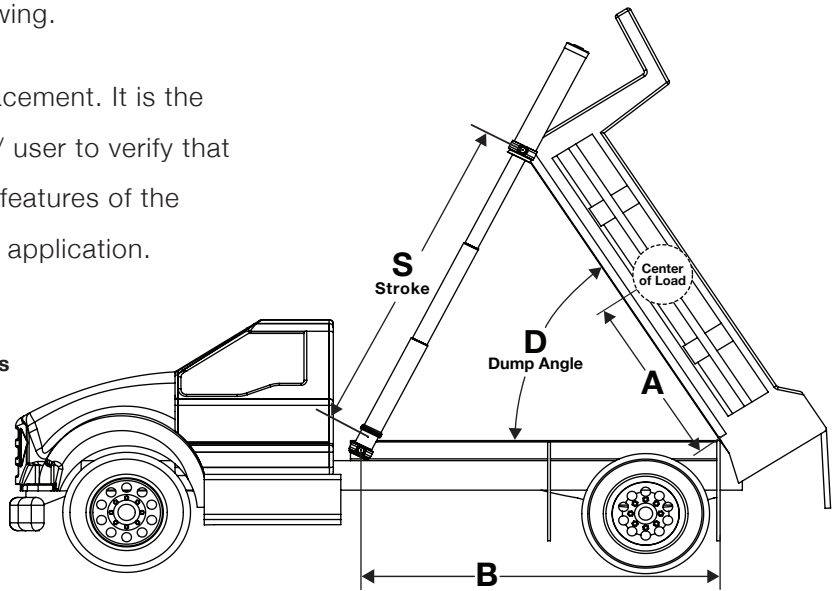

Dump Angle*	42°	43°	44°	45°	46°	47°	48°	49°	50°	51°	52°	53°	54°	55°	56°	57°
"D"	.670	.683	.696	.708	.720	.732	.744	.756	.767	.778	.789	.800	.810	.821	.830	.840

**To calculate the appropriate cylinder stroke to achieve a determined dump angle:**

**Approximate Stroke (inches) = "B" x "D"**

- Example: B = 180" and Desired Dump Angle = 50°
- Approximate Cylinder Stroke = 180" x .767
- Approximate Cylinder Stroke = 138"

**To calculate the initial required cylinder force to lift a load:**

**Force required to lift a load = [Load (lbs) x "A"]/"B"**

- Example: Load = 40,000 lbs, A = 90", and B = 180"
- Force required = [40,000 lbs x 90"]/180"
- Force Required = 20,988 lbs

## LIFTING CAPACITY AT GIVEN PRESSURES FOR EACH STAGE DIAMETER

Series*	Stage Dia. (in)	Eff. Area (in <sup>2</sup> )	800 PSI	1,000 PSI	1,500 PSI	2,000 PSI	2,500 PSI
7.5	6.65	34.73	27,786	34,732	52,098	69,465	86,831
6.5	5.87	27.06	21,650	27,062	40,594	54,125	67,656
5.5	5.08	20.27	16,215	20,268	30,402	40,537	50,671
-	4.37	15.00	11,999	14,999	22,498	29,997	37,497
-	3.74	10.99	8,789	10,986	16,479	21,972	27,465
4.5	3.54	9.84	7,874	9,842	14,763	19,685	24,606
3.5	2.95	6.83	5,468	6,835	10,252	13,670	17,087
-	2.36	4.37	3,499	4,374	6,562	8,749	10,936
-	1.77	2.46	1,968	2,461	3,691	4,921	6,151

\*For a given series, the largest (first) stage is given in the column to the right of the "Series" column. The second stage of that cylinder series is listed directly below the first stage. Therefore the first stage of the "6.5" Series is 5.87 in. diameter, while the second stage is the 5.08 in. diameter, and finally the last is the 3.74 in. diameter.

Note: A properly designed system should operate at approximately 800 psi or less during the start of the lift. The load imposed on a cylinder by a dump body is dynamic, and as such, your system pressure will be changing to accommodate the difference in force required to lift the

changing load. You will see system pressure increase as your cylinder extends from stage to stage. You will also see a decrease in cycle time due to the effective volume change from stage to stage as the cylinder extends (your cylinder will move faster).

# 3.5 & 4.5 SERIES CYLINDERS

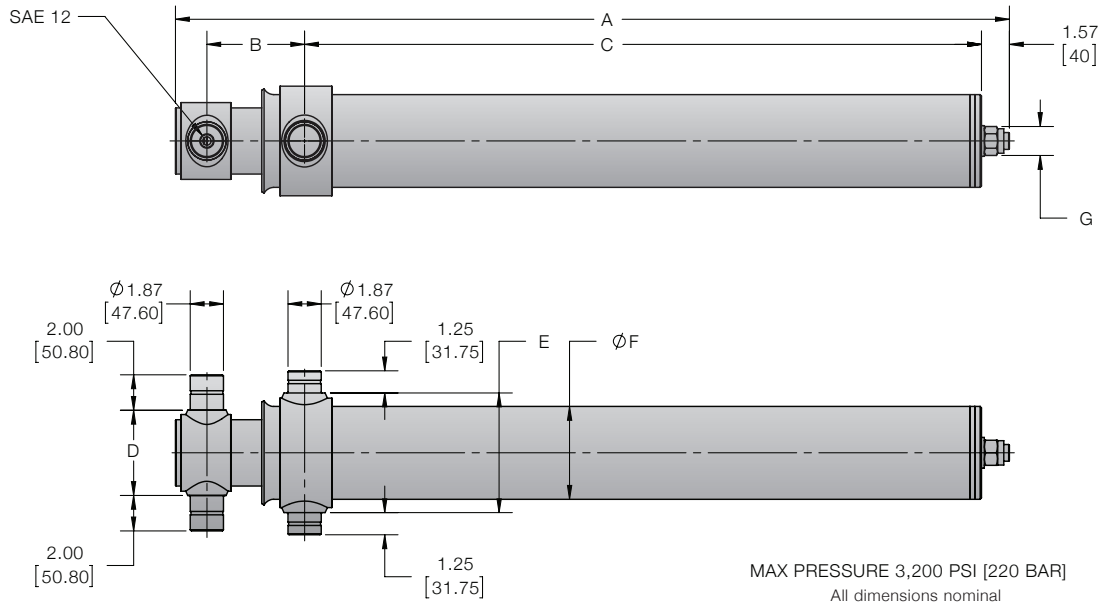

## ENGLISH MEASUREMENTS

Model No.	Stroke Length (in)	A	B	C	D	E	F	G	Stage Diameter (in) 1 / 2 / 3	Fill / Extend (Gal)	Cylinder Weight (lbs)
3.5-3-110-B00*	111	47.05	5.51	38.19	4.8	6.75	5.24	M24x3	2.95 / 2.36 / 1.17	0.36 / 2.2	161
4.5-3-090-B00*	90	40.16	5.24	31.59	5.75	8.03	6.26	M39x3	3.54 / 2.95 / 2.36	0.36 / 2.7	198

## METRIC MEASUREMENTS

Model No.	Stroke Length (cm)	A	B	C	D	E	F	G	Stage Diameter (cm) 1 / 2 / 3	Fill / Extend (L)	Cylinder Weight (Kg)
3.5-3-110-B00*	281.9	119.5	14.0	97.0	12.2	17.1	13.3	M24x3	7.5 / 6.0 / 4.5	1.4 / 8.3	73.0
4.5-3-090-B00*	228.6	102.0	13.3	80.2	14.6	20.4	15.9	M39x3	9.0 / 7.5 / 6.0	1.4 / 10.2	89.8

## CYLINDER REBUILD & SEAL KITS

Cylinders Used With	Seal Kit Number	Rebuild Kit Number
3.5-3-110-B00	GSK-3.53-00	RBK-3.53-00
4.5-3-090-B00	GSK-3.53-00	RBK-4.53-00

Note: Rebuild kits include upper and lower guides, seals and wipers for each stage. Seal kits only include seals and wipers for each stage.

# 5.5, 6.5 & 7.5 SERIES CYLINDERS

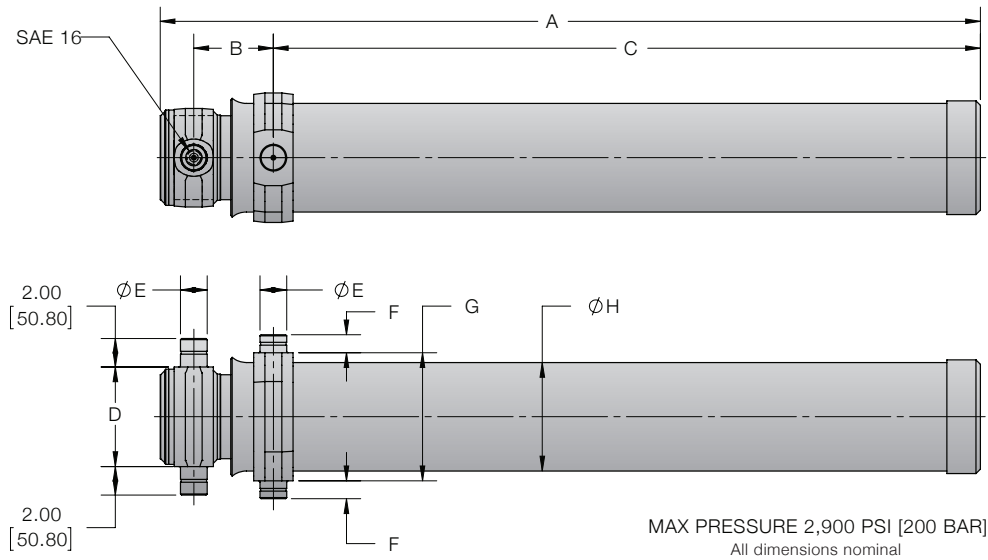

## ENGLISH MEASUREMENTS

Model No.	Stroke Length (in)	A	B	C	D	E	F	G	H	Stage Diameter (in) 1 / 2 / 3 / 4	Fill / Extend (Gal)	Cylinder Weight (lbs)
5.5-3-138-B00	138	57.6	5.59	49.7	6.99	1.87	1.26	9.0	7.6	5.08 / 4.37 / 3.74	0.90 / 9.1	356
6.5-4-146-B00	146	48.5	6.85	39.3	7.99	2.24	1.50	10.2	8.6	5.87 / 5.08 / 4.37 / 3.74	1.1 / 11.4	397
6.5-4-160-B00	160	53.2	6.85	44.0	7.99	2.24	1.50	10.2	8.6	5.87 / 5.08 / 4.37 / 3.74	1.2 / 12.7	431
6.5-4-170-B00	169	55.0	6.85	45.8	7.99	2.24	1.50	10.2	8.6	5.87 / 5.08 / 4.37 / 3.74	1.2 / 13.5	444
6.5-4-180-B00	180	55.0	6.85	45.8	7.99	2.24	1.50	10.2	8.6	5.87 / 5.08 / 4.37 / 3.74	1.3 / 14.4	444
7.5-4-182-B00	182	61.1	8.78	49.7	9.02	2.24	1.50	12.8	9.63	6.65 / 5.87 / 5.08 / 4.37	1.6 / 19.4	667
7.5-4-194-B00	194	61.1	8.78	49.7	9.02	2.24	1.50	12.8	9.63	6.65 / 5.87 / 5.08 / 4.37	1.7 / 20.2	667

## METRIC MEASUREMENTS

Model No.	Stroke Length (cm)	A	B	C	D	E	F	G	H	Stage Diameter (cm) 1 / 2 / 3 / 4	Fill / Extend (L)	Cylinder Weight (Kg)
5.5-3-138-B00	350.52	146.3	14.2	126.2	17.75	4.75	3.2	22.86	19.3	12.9 / 11.1 / 9.5	3.4 / 34.4	161.5
6.5-4-146-B00	370.84	123.2	17.4	99.82	20.29	5.69	3.81	25.91	21.84	14.9 / 12.9 / 11.1 / 9.5	4.0 / 43.1	180.1
6.5-4-160-B00	406.0	135.1	17.4	111.8	20.29	5.69	3.81	25.91	21.84	14.9 / 12.9 / 11.1 / 9.5	4.4 / 48.1	195.5
6.5-4-170-B00	429.26	139.7	17.4	116.3	20.29	5.69	3.81	25.91	21.84	14.9 / 12.9 / 11.1 / 9.5	4.6 / 51.1	201.4
6.5-4-180-B00	457.2	139.7	17.4	116.3	20.29	5.69	3.81	25.91	21.84	14.9 / 12.9 / 11.1 / 9.5	4.8 / 54.5	201.4
7.5-4-182-B00	462.28	155.2	22.3	126.2	22.91	5.69	3.81	32.51	24.46	16.9 / 14.9 / 12.9 / 11.1	6.1 / 73.4	302.6
7.5-4-194-B00	492.76	155.2	22.3	126.2	22.91	5.69	3.81	32.51	24.46	16.9 / 14.9 / 12.9 / 11.1	6.3 / 76.5	302.6

## CYLINDER REBUILD & SEAL KITS

Cylinders Used With	Seal Kit Number	Rebuild Kit Number
5.5-3-138-B00	GSK-5.53-00	RBK-5.53-00
6.5-4-XXX-B00	GSK-6.54-00	RBK-6.54-00
7.5-4-XXX-B00	GSK-7.54-00	RBK-7.54-00

Note: Rebuild kits include upper and lower guides, seals and wipers for each stage. Seal kits only include seals and wipers for each stage.

# TWO-YEAR CYLINDER WARRANTY

---

Muncie's trunnion mount cylinder is warranted against any defect in material and workmanship which existed at the time of sale by Muncie Power Products, Inc., according to the following provisions, subject to the requirements that the cylinder must be used only in accordance with catalog and package instructions.

The cylinder is warranted for a period of two years from the date of installation. If during the warranty period the cylinder fails to operate to Muncie's specifications due to a defect in any part, material or workmanship that existed at the time of sale by Muncie, the defective part will be repaired or replaced, at Muncie's election, at no charge, if the defective part is returned to Muncie with transportation prepaid.

**WARNING:** The warranty shall terminate if any alterations or repairs are made to the cylinder other than at a Muncie Power Products facility, or if the cylinder is used on any equipment other than the equipment upon which first installed.

The foregoing warranties are in lieu of all other obligations and liabilities, including negligence and all warranties of merchantability and suitability, expressed or implied and state Muncie Power Products' entire and exclusive liability and buyer's exclusive remedy for any claim of damages in connection with the sale, repair or replacement of above goods, their design, installation or operation. Muncie Power Products will in no event be liable for any direct, indirect, special, incidental or consequential damages whatsoever, and our liability under no circumstances will exceed the contract price for the goods for which liability is claimed.



W W W . M U N C I E P O W E R . C O M

MP14-01 (1-14) • © Muncie Power Products, Inc. 2014 • 201 E. Jackson St. Muncie, IN 47305 • 1-800-367-7867  
All rights reserved. Specifications are subject to change without notice. Drive Products, exclusive agents for Canada.

