

PIN-PIN CYLINDERS

SINGLE-ACTING TELESCOPIC



HIGH PERFORMANCE IN A LIGHTER CYLINDER

The combination of strict machining tolerances, solid stop contact faces and larger overlap between the stages has resulted in one of the strongest and most stable cylinder columns currently available on the market. These improvements help to increase safety for dumping applications, helping to prevent accidents due to vehicle roll-over.

KEY FEATURES

- Self-bleeding design for easier installation process
- No packing or head nuts on each stage. Only one head nut that doesn't need adjustments
- Chrome-plated final stage extends the life of the cylinder
- Solid stops machined into top and bottom of each stage, eliminating stop rings and threaded stops
- Stages are machined and precision ground inside and out to allow for optimal seal / wiper performance
- Each cylinder is equipped with bearing supports at both the top and bottom. Longer stages have increased overlap for improved column stability.
- Tight machining tolerances cause smaller tube clearances that result in increased rigidity
- One of the lightest cylinders on the market which translates to greater payloads, less oil consumption and faster dumping
- Low maintenance requirements offer many years of top performance without additional expenses



QUALITY MATERIALS

- All steel tubing are made from seamless hot rolled steel, this results in higher tensile tubes for increased column strength and stiffness
- Stages have no welded seems allowing for higher pressure capabilities
- The quality steel used increases resistance to mechanical stress and increases cylinder life
- Seals and wipers are made of polyurethane and feature a double lip design assuring optimum performance in all climate conditions (-40°F to 212°F / -40°C to 100°C)
- Bearing supports are made of DELRIN®, they are compatible with all types of hydraulic oils approved by pump makers and are capable of withstanding high and low pressures

DUMP BODY CYLINDER CALCULATIONS

These calculations provide approximate values. Final calculations and product selection should be determined by a qualified engineer and engineering drawing.

When selecting a hydraulic cylinder for replacement. It is the responsibility of the purchaser and installer / user to verify that all dimensions, mounting, and performance features of the replacement cylinder are appropriate for the application.

- A = Dump hinge pin to center of load in inches**
- B = Dump hinge pin to cylinder base pin in inches**
- D = Dump body to frame angle**
- S = Stroke of cylinder**

*Normal minimum dump angle is 45° and normal maximum dump angle is 57°.

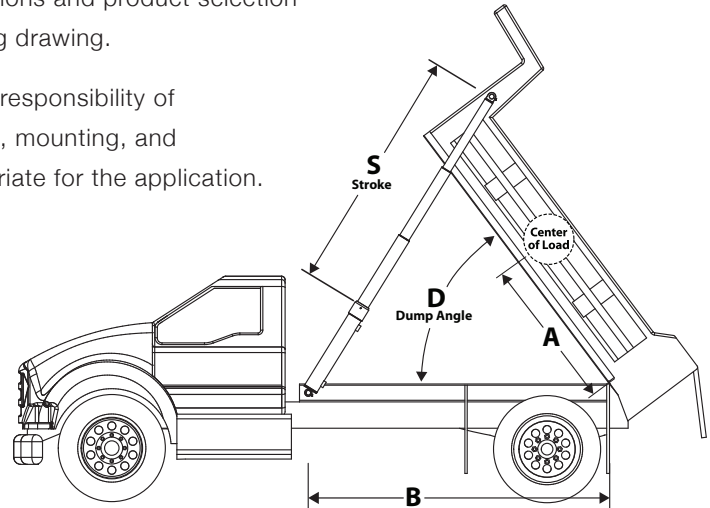

Dump Angle*	42°	43°	44°	45°	46°	47°	48°	49°	50°	51°	52°	53°	54°	55°	56°	57°
"D"	.715	.733	.750	.765	.780	.797	.813	.830	.845	.861	.877	.892	.903	.923	.939	.954

CYLINDER STROKE

Approximate Stroke (inches) = "B" x "D"

- Example: B = 162" and Desired Dump Angle = 49°
- Approximate Cylinder Stroke = 162" x .830
- Approximate Cylinder Stroke = 135"

REQUIRED FORCE

Force required to lift a load = [Load (lbs) x "A"] / "B"

- Example: Load = 40,000 lbs, A = 85 in, and B = 162 in
- Force required = [40,000 lbs x 85 in] / 162 in
- Force Required = 20,988 lbs

LIFTING CAPACITY AT GIVEN PRESSURES FOR EACH STAGE DIAMETER

Stage Dia. (in)	Eff. Area (in ²)	800 PSI	1,000 PSI	1,500 PSI	2,000 PSI	2,500 PSI
6.85	36.85	29,482	36,853	55,279	73,706	92,132
6.06	28.84	23,074	28,843	43,264	57,685	72,107
5.31	22.15	17,716	22,145	33,218	44,290	55,363
4.57	16.40	13,122	16,403	24,604	32,806	41,007
3.86	11.70	9,362	11,702	17,553	23,404	29,255
3.11	7.60	6,077	7,596	11,395	15,193	18,991

Notes:

A properly designed system should operate at approximately 800 psi or less during the start of the lift. The load imposed on a cylinder by a dump body is dynamic, and as such, your system pressure will be changing to accommodate the difference in force required to lift the changing load. You will see system pressure increase as your cylinder extends from stage to stage. You will also see a decrease in cycle time due to the effective volume change from stage to stage as the cylinder extends (your cylinder will move faster).

MODEL NUMBER CONSTRUCTION

8 - 5 - 265 - A00

- SERIES**
(8, 7, 6, 5)
- NUMBER OF STAGES**
5 - (8 Series only)
4 - (7 Series only)
3 - (5 & 6 Series only)

- DESIGN CODE**
STYLE: A - PIN TO PIN
- NOMINAL STROKE (IN)**
See next page for standard size availability

DIMENSIONS

ENGLISH MEASUREMENTS

Model No.	Stroke Length (in)	A= Closed / Open Length (in)	B= Port to Port (in)	C= Base Pin Width (in)	D= Tube OD (in)	Stage Diameter (in) 1 / 2 / 3 / 4 / 5	Fill / Extend (Gal)	Cylinder Weight (lbs)
5-3-084-A00	85.91	39.57 / 125.48	20.3	7.00	5.39	4.57 / 3.86 / 3.11	0.52 / 4.40	179
5-3-104-A00	103.23	47.32 / 150.55	28.3	7.00	5.39	4.57 / 3.86 / 3.11	0.62 / 5.26	220
6-3-084-A00	84.02	39.57 / 123.59	20.31	7.00	6.18	5.31 / 4.57 / 3.86	0.60 / 6.12	189
6-3-104-A00	102.28	47.32 / 149.6	28.3	7.00	6.18	5.31 / 4.57 / 3.86	0.72 / 7.35	255
6-3-110-A00	109.61	49.76 / 159.37	30.79	7.00	6.18	5.31 / 4.57 / 3.86	0.76 / 7.93	278
6-3-120-A00	118.35	52.48 / 170.83	33.5	7.00	6.18	5.31 / 4.57 / 3.86	0.82 / 8.55	280
6-3-126-A00 ²	126.02	54.96 / 180.98	36.0	7.00	6.18	5.31 / 4.57 / 3.86	0.88 / 9.18	300
6-3-130-A00	128.46	55.75 / 184.21	36.0	7.00	6.18	5.31 / 4.57 / 3.86	0.88 / 9.24	300
6-3-140-A00 ³	140.00	59.80 / 199.80	40.6	7.00	6.18	5.31 / 4.57 / 3.86	0.92 / 10.19	329
7-3-110-A00	109.69	49.92 / 159.61	30.79	8.23	6.93	6.06 / 5.31 / 4.57	0.88 / 10.62	303
7-4-135-A00	135.67	47.76 / 183.43	27.6	8.23	6.93	6.06 / 5.31 / 4.57 / 3.86	1.04 / 11.49	330
7-4-156-A00	157.68	52.91 / 210.59	33.5	8.23	6.93	6.06 / 5.31 / 4.57 / 3.86	1.19 / 13.43	365
7-4-161-A00	162.99	55.39 / 218.38	36.5	8.23	6.93	6.06 / 5.31 / 4.57 / 3.86	1.24 / 14.14	374
7-4-167-A00 ⁴	167.01	55.39 / 222.40	36.5	8.23	6.93	6.06 / 5.31 / 4.57 / 3.86	1.29 / 14.44	374
8-4-170-A00	168.98	56.65 / 225.63	36.65	9.49	7.87	6.85 / 6.06 / 5.31 / 4.57	1.42 / 19.15	467
8-5-169-A00	168.94	47.95 / 216.89	28.35	9.49	7.87	6.85 / 6.06 / 5.31 / 4.57 / 3.86	1.37 / 16.87	425
8-5-190-A00	188.98	53.98 / 242.96	32.1	9.49	7.87	6.85 / 6.06 / 5.31 / 4.57 / 3.86	1.53 / 18.70	464
8-5-220-A00	219.92	59.88 / 279.8	39.1	9.49	7.87	6.85 / 6.06 / 5.31 / 4.57 / 3.86	1.75 / 21.74	531
8-5-235-A00	235.00	64.53 / 299.53	44.9	9.49	7.87	6.85 / 6.06 / 5.31 / 4.57 / 3.86	1.89 / 23.34	584
8-5-250-A00	246.89	68.35 / 315.24	44.9	9.49	7.87	6.85 / 6.06 / 5.31 / 4.57 / 3.86	1.95 / 24.53	588
8-5-265-A00	265.83	69.72 / 335.55	48.7	9.49	7.87	6.85 / 6.06 / 5.31 / 4.57 / 3.86	2.09 / 26.35	620
8-5-285-A00	285.98	75.87 / 361.85	56.8	9.49	7.87	6.85 / 6.06 / 5.31 / 4.57 / 3.86	2.28 / 29.55	690

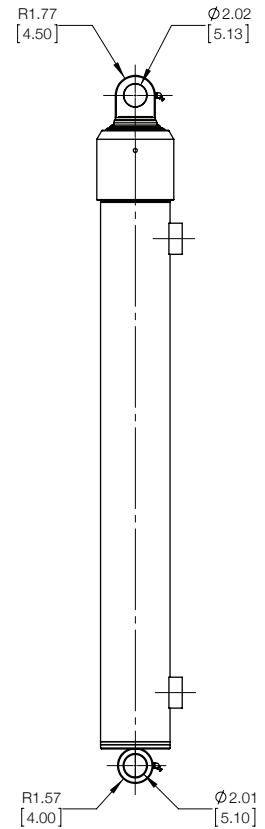

METRIC MEASUREMENTS

Model No.	Stroke Length (cm)	A= Closed / Open Length (cm)	B= Port to Port (cm)	C= Base Pin Width (cm)	D= Tube OD (cm)	Stage Diameter (cm) 1 / 2 / 3 / 4 / 5	Fill / Extend (L)	Cylinder Weight (kg)
5-3-084-A00	218.2	100.5 / 318.7	51.6	17.78	13.69	11.60 / 9.80 / 7.90	1.97 / 16.65	81
5-3-104-A00	262.2	120.2 / 382.4	71.9	17.78	13.69	11.60 / 9.80 / 7.90	2.35 / 19.91	100
6-3-084-A00	213.4	100.5 / 313.9	51.6	17.78	15.70	13.49 / 11.60 / 9.80	2.27 / 23.16	86
6-3-104-A00	259.8	120.2 / 380.1	71.9	17.78	15.70	13.49 / 11.60 / 9.80	2.73 / 27.82	116
6-3-110-A00	278.4	126.4 / 404.8	78.2	17.78	15.70	13.49 / 11.60 / 9.80	2.88 / 30.02	126
6-3-120-A00	300.6	133.3 / 433.9	85.1	17.78	15.70	13.49 / 11.60 / 9.80	3.10 / 32.36	127
6-3-126-A00 ²	320.1	139.6 / 459.7	91.4	17.78	15.70	13.49 / 11.60 / 9.80	3.33 / 34.74	136
6-3-130-A00	326.3	141.6 / 467.9	91.4	17.78	15.70	13.49 / 11.60 / 9.80	3.33 / 34.97	136
6-3-140-A00 ³	355.6	151.9 / 507.5	103.1	17.78	15.70	13.49 / 11.60 / 9.80	3.48 / 38.57	149
7-3-110-A00	278.6	126.8 / 405.4	78.2	20.90	17.60	15.39 / 13.49 / 11.60	3.33 / 40.20	137
7-4-135-A00	344.6	121.3 / 465.9	70.0	20.90	17.60	15.39 / 13.49 / 11.60 / 9.80	3.94 / 43.49	150
7-4-156-A00	400.5	134.4 / 534.9	85.0	20.90	17.60	15.39 / 13.49 / 11.60 / 9.80	4.50 / 50.83	166
7-4-161-A00	414.0	140.7 / 544.7	92.6	20.90	17.60	15.39 / 13.49 / 11.60 / 9.80	4.69 / 53.52	170
7-4-167-A00 ⁴	424.2	140.7 / 564.9	92.6	20.90	17.60	15.39 / 13.49 / 11.60 / 9.80	4.88 / 54.65	170
8-4-170-A00	429.2	143.9 / 573.1	93.1	24.10	19.99	17.40 / 15.39 / 13.49 / 11.60	5.40 / 72.5	211.8
8-5-169-A00	429.1	121.8 / 550.9	72.0	24.10	19.99	17.40 / 15.39 / 13.49 / 11.60 / 9.80	5.19 / 63.85	193
8-5-190-A00	480.0	137.1 / 617.1	81.6	24.10	19.99	17.40 / 15.39 / 13.49 / 11.60 / 9.80	5.79 / 70.78	210
8-5-220-A00	558.6	152.1 / 710.7	99.3	24.10	19.99	17.40 / 15.39 / 13.49 / 11.60 / 9.80	6.62 / 82.28	241
8-5-235-A00	596.9	163.9 / 760.8	114.1	24.10	19.99	17.40 / 15.39 / 13.49 / 11.60 / 9.80	7.15 / 88.34	265
8-5-250-A00	627.1	173.6 / 800.7	114.1	24.10	19.99	17.40 / 15.39 / 13.49 / 11.60 / 9.80	7.38 / 92.85	267
8-5-265-A00	675.2	177.1 / 852.3	123.8	24.10	19.99	17.40 / 15.39 / 13.49 / 11.60 / 9.80	7.91 / 99.73	281
8-5-285-A00	726.4	192.7 / 919.1	144.3	24.10	19.99	17.40 / 15.39 / 13.49 / 11.60 / 9.80	8.63 / 111.85	313

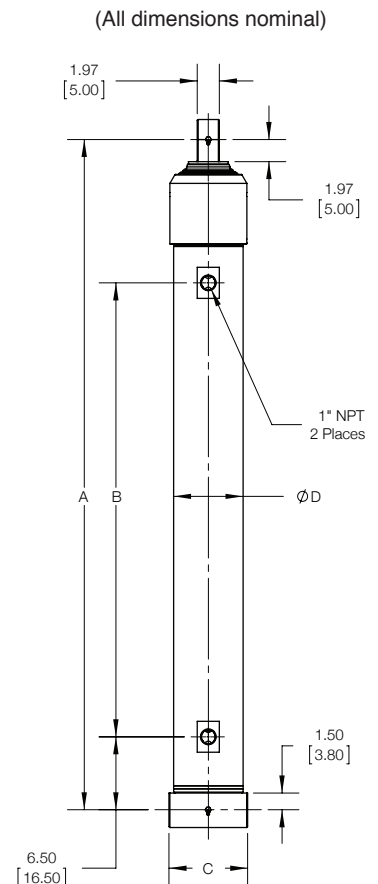

Notes:

1. All cylinders MAX pressure: 2,750 PSI (189.7 BAR) due to NPT ports (rated for 2,900 PSI (200 BAR))
2. 6-3-126-A00 cylinders with serial numbers starting with "12 or 13" will have a stroke of 128.46 in (320.1 cm)
3. 6-3-140-A00 cylinders with serial numbers starting with "12 or 13" will have a stroke of 135.47 in (355.6 cm) and closed "A" length of 59.65 in (151.9 cm)
4. 7-4-167-A00 cylinders with serial numbers starting with "12 or 13" will have a stroke of 171.42 in (424.2 cm)

PIN-EYE BUSHINGS FOR TOP PIN

Description	Part Number
2.00 OD X 1.31 ID X 2.00 W	18T42905-131200
2.00 OD X 1.50 ID X 1.50 W	18T42905-150150
2.00 OD X 1.50 ID X 2.00 W	18T42905-150200
2.00 OD X 1.68 ID X 2.00 W	18T42905-168200
2.00 OD X 1.75 ID X 1.50 W	18T42905-175150
2.00 OD X 1.75 ID X 2.00 W	18T42905-175200

PIN-EYE MOUNT SPACERS

Description	Part Number
3.00 OD X 1.81 ID X 0.25 W	18T42906-181025
3.00 OD X 1.81 ID X 0.50 W	18T42906-181050
3.00 OD X 1.81 ID X 0.75 W	18T42906-181075
3.00 OD X 1.81 ID X 1.00 W	18T42906-181100
3.00 OD X 2.12 ID X 0.25 W	18T42906-212025
3.00 OD X 2.12 ID X 0.50 W	18T42906-212050
3.00 OD X 2.12 ID X 0.75 W	18T42906-212075
3.00 OD X 2.12 ID X 1.00 W	18T42906-212100

CYLINDER SEAL AND REBUILD KITS

Seal kits contain all seals and wipers needed for each stage. Rebuild kits contain all seals, wipers and bearing supports needed for each stage.

Cylinder Model	Seal Kit No.	Rebuild Kit No.
5-3-XXX-A00	GSK-53-00	RBK-53-00
6-3-XXX-A00	GSK-63-00	RBK-63-00
7-3-110-A00	GSK-73-00	RBK-73-00
7-4-XXX-A00	GSK-74-00	RBK-74-00
8-4-XXX-A00	GSK-84-00	RBK-84-00
8-5-XXX-A00	GSK-85-00	RBK-85-00

