



# EOS-110

## ELECTRONIC OVERSPEED SWITCH



### ***AUTOMATICALLY PROTECTS POWER EQUIPMENT FROM ENGINE OVERSPEED DAMAGE***

**SAVES** on parts replacements and downtime by automatically switching off power equipment when an excessive operating speed is reached. Automatically re-engages when engine is reduced to a safe speed.

Allows full operator control within set limits.

Adjustable broad speed range from 300 RPM minimum to 3000 RPM.

Tamper-resistant. No mechanical connections required.

A full One-Year Warranty.



---

## **EOS-110 APPLICATIONS**

Ideal for Packers and other power equipment applications:

- REAR LOADER • FRONT LOADER • SIDE LOADER • SNOW PLOW •
  - DIGGER/DERRICK • AERIAL BASKET •
-

# EOS-110 ELECTRONIC OVERSPEED SWITCH

**NO MOVING PARTS • ADAPTABLE TO ANY GASOLINE OR DIESEL ENGINE**

The EOS-110 protects power take-offs and hydraulic truck equipment from operator abuse by switching off the equipment when an excessive engine speed is reached. The equipment is automatically reengaged when the engine is slowed to a safe operating speed.

The EOS-110 can control Clutch Shift power take-offs, clutch pumps, or dry valve pumps. It protects pumps, drivelines, power take-offs and cylinders. Actually, the EOS-110 is made to protect any device or any system which could be damaged from overspeeding or engagement at overspeed.

The EOS-110 allows full operator control within predetermined limits. Speeds can be adjusted from 300 RPM minimum to 3000 RPM.

Dependability is engineered into the EOS-110 and Muncie provides a full One-Year Warranty. The compact unit is a solid state sensor...there are no moving parts to wear out. The EOS-110 is adaptable to any gasoline or diesel engine using an alternator or an optional PTO pulse generator. Installation is easy, with no mechanical connections required. The EOS-110 comes with all parts and easy-to-follow installation instructions.

## GOOD NEWS FOR PACKER FLEET OPERATORS!

If your packer fleet uses Allison Automatic Transmissions without Clutch Shift PTOs, then you're probably spending a considerable amount on transmission repairs as well as replacing many PTOs. By adding a Muncie Clutch Shift PTO in combination with the EOS-110 you'll realize tremendous savings on parts replacements and downtime costs. Contact Muncie's sales department at (765) 284-7721 for full information on the Clutch Shift PTO/EOS-110 combination.

## STATE-OF-THE-ART COMPONENTRY

*ALLOWS FOR EASY ADJUSTMENTS AND INSURES LONG-LIFE OPERATION*

- Adjustment procedures are clearly explained.
- Test jacks (on underside of EOS-110) easily accept voltmeter probe.
- The EOS-110 is contained in a glass-filled nylon case that is impact resistant. The compact size of the case makes it easier to handle and install.
- A positive, tight connector seals the EOS-110 from moisture and grime.
- Updated components used in the EOS-110 offer state-of-the-art electronics for greater reliability.
- The EOS-110 is gasket mounted to seal out moisture and contaminants.
- The EOS-110 accepts various sensors, alternators, and optional PTO pulse generators.

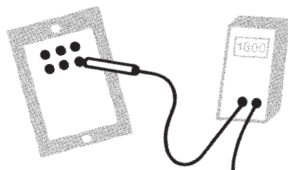

## EOS-110 DIMENSIONS

*IN INCHES*

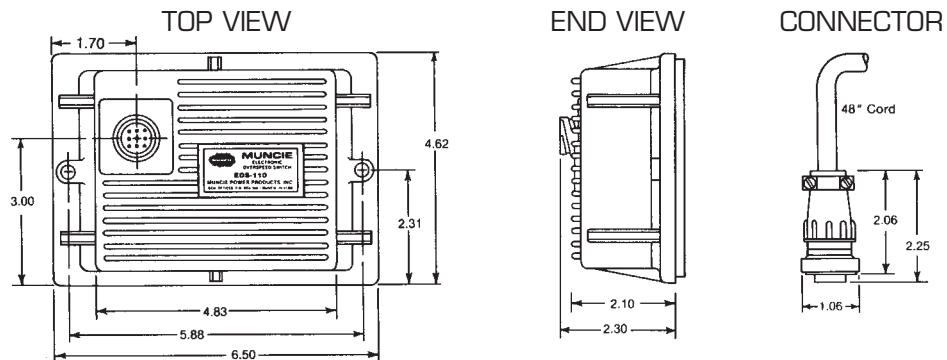

**Muncie Power Products, Inc.** General Offices and Distribution Center • P.O. Box 548 • Muncie, IN 47308-0548  
(765) 284-7721 • FAX (765) 284-6991 • E-mail [info@munciepower.com](mailto:info@munciepower.com) • Web site <http://www.munciepower.com>  
Drive Products, Inc., Toronto, Exclusive Agents for Canada