

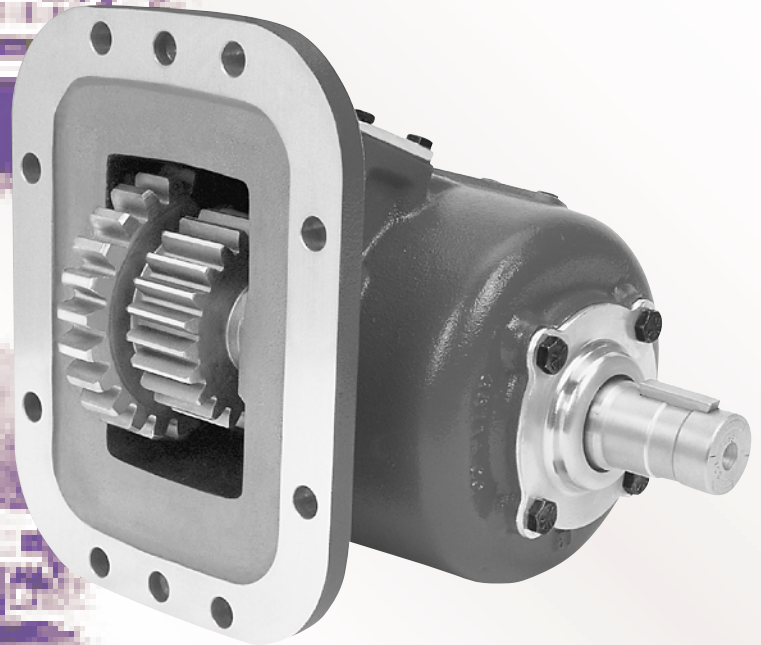

CS6 & CS8 SERIES

CLUTCH SHIFT PTO

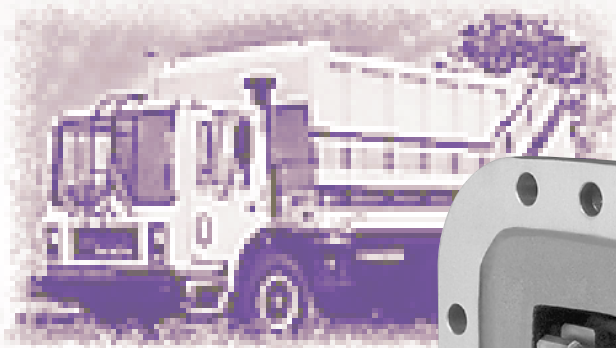

CS6 & CS8 Series PTO
U.S. Pat. 5,542,306

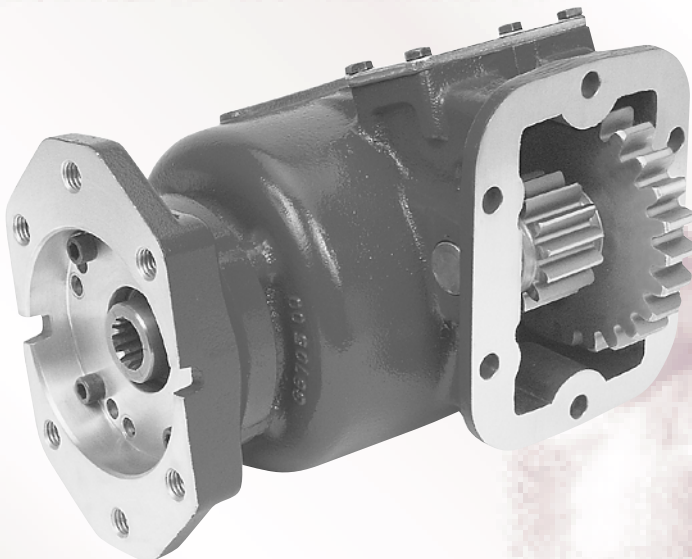



CS6 & CS8 SERIES CLUTCH SHIFT PTO

NOW YOU CAN PROVIDE POWERSHIFTED PTO POWER FOR AUTOMATIC AND STANDARD TRANSMISSIONS WITH MUNCIE'S NEW CS6 & CS8 PTO.

The internal wet clutch permits easy engagement and disengagement without the need to stop the PTO drive gear. This prevents gear clash and reduces new operator training time. The enhanced capacity design of the CS6 & CS8 includes many features of the popular Muncie CS10 & CS20 PTOs made for the Allison World Transmissions.

The CS6 & CS8 PTO is specifically designed to fit the older model Allison AT, MT, & HT Series transmissions as well as the Fuller CEEMAT. Using eleven input gear designs and seven internal speed ratios, these new CS Series PTO models also meet requirements for many popular Clark, Fuller, JATCO, Mack and Spicer transmissions often selected for similar chassis. Additionally, the CS8 provides convenient mounting on 8-bolt openings without special adapters.

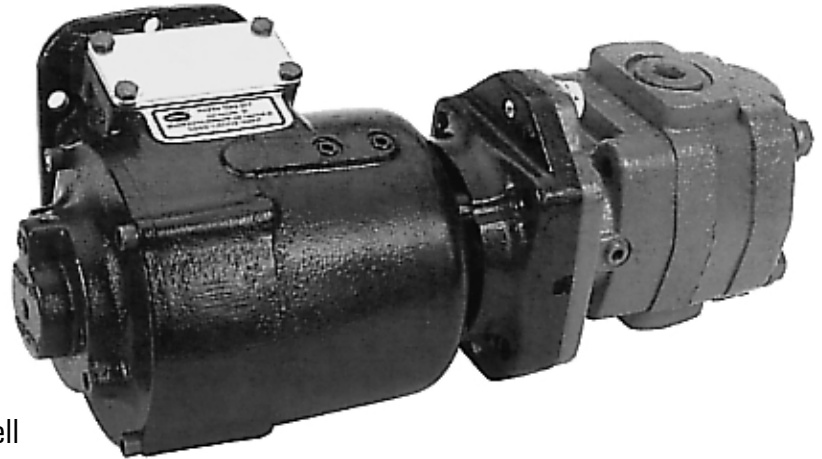

The CS Series is available with standard 1¼" round output shaft, or with several direct mount hydraulic flange and shaft options, all with the convenience of rotatable flanges that can be easily repositioned to gain pump mounting clearance or to access hydraulic ports. These flanges interchange with other Muncie PTO series.

CS6 & CS8 PTO FEATURES INCLUDE:

- **High Strength Ductile Iron Housings**
 - **Torque Ratings From 275–350 lb.ft.**
 - **Patented Internal Drag Brake Eliminates Unwanted Shaft Rotation...A Must For Product Pump Applications**
 - **Three Ways To Shift: Hydraulic, Air, Electric/Air**
 - **Allows For Overspeed Protection**
-

CS6 & CS8 DIMENSIONS IN INCHES (MM)

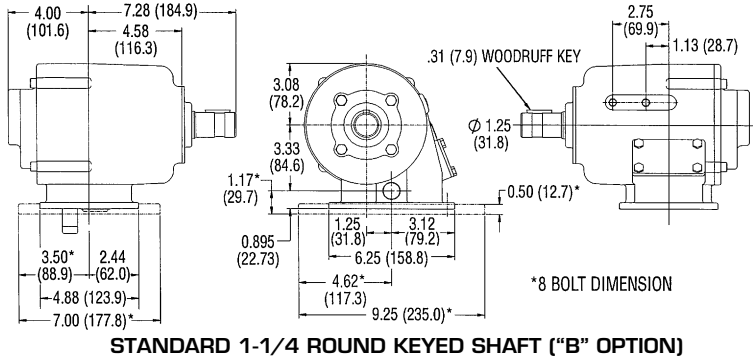

STANDARD 1-1/4 ROUND KEYED SHAFT ("B" OPTION)

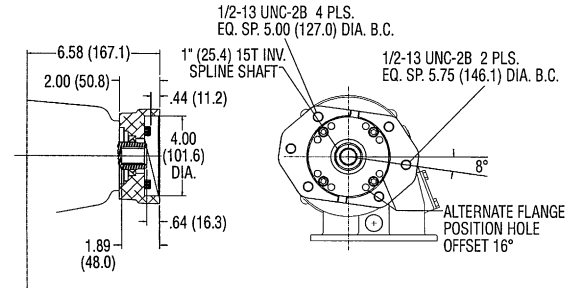

SAE "BB" 2 & 4 BOLT 1"-15 SPLINE ("P" OPTION)

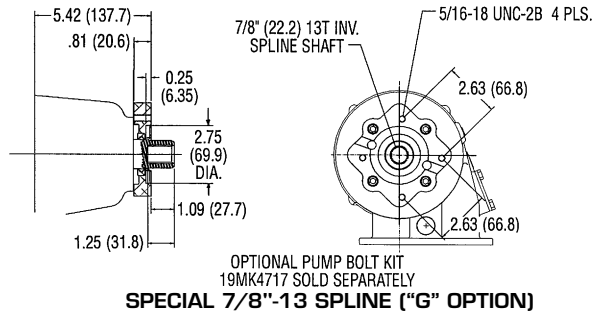

SPECIAL 7/8"-13 SPLINE ("G" OPTION)

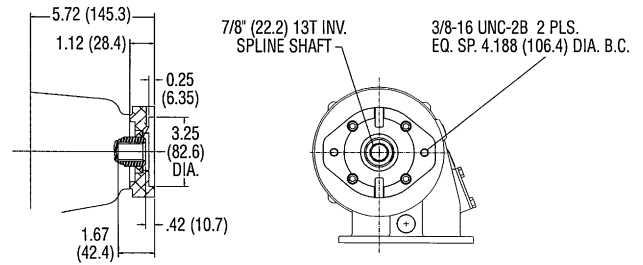

SAE "A" 2 BOLT 7/8"-13 SPLINE ("Q" OPTION)

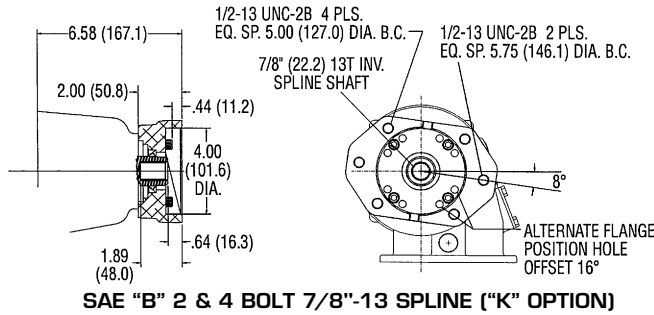

SAE "B" 2 & 4 BOLT 7/8"-13 SPLINE ("K" OPTION)

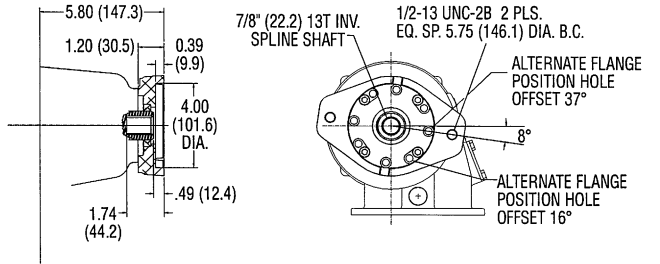

SAE "B" 2 BOLT 7/8"-13 SPLINE ("S" OPTION)

MODEL NUMBER CONSTRUCTION

CS 6S — M65 07 — E 1 B X

PTO Type

Clutch Shift — CS

Mounting

SAE 6 Bolt Std. Mtg. — 6S
 SAE 6 Bolt Non-Std. Mtg. — 6D
 SAE 6 Bolt Non-Std. Mtg. (Isuzu) — 6N
 SAE 8 Bolt Std. Mtg. — 8S
 SAE 8 Bolt Non-Std. Mtg. — 8D

Trans.

CS Gear Data

Clark/Fuller	6.1P 25°PA 32° 16' 48" LH	— C61
Clark/Fuller	7P 25°PA 30° 46' 48" LH	— C70
Fuller	6.35P 20°PA 22° LH	— F63
Fuller	8.5P 21°PA Spur	— F85
Isuzu (JATCO)	8.46P 20°PA Spur	— I85
Mack	6.48P 17.5°PA Spur	— M65
Spicer	6P 17.5°PA 26° 10' 37"	— S60
Spicer	7P 17.5°PA 28° 4' 23"	— S70
Spicer	6P or 6/8P 20°PA Spur	— S68
Universal	6P 20°PA Spur	— U60
Universal	6P or 6/8P 20°PA Spur	— U68

Speed Ratio

03 — .33:1	07 — .70:1	
04 — .44:1	09 — .87:1	
05 — .47:1	12 — 1.15:1	14 — 1.44:1 (8 Bolt Only)

Special Feature

X — None
 C — Pulse Generator/Pres Lube/EOS-111
 D — Pulse Generator/EOS-111
 P — Pressure Lube
 R — Pulse Generator/No Pressure Lube
 S — Pulse Generator/Pressure Lube

Output Type

B — 1-1/4 Round 5/16 KW
 G — Special
 K — SAE "B" 2 & 4 Bolt
 Q — SAE "A" 2 Bolt
 P — SAE "BB" 2 & 4 Bolt
 S — SAE "B" 2 Bolt

Assembly Arrangement

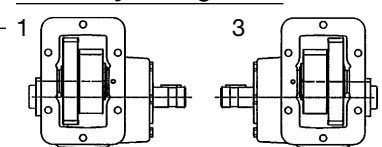

Shifter Type

A — Manual Air	H — Elect/Hyd (12V)
E — Elect/Air (12V)	J — Elect/Hyd (24V)
F — Elect/Air (24V)	

POWER TAKE-OFF WARRANTY

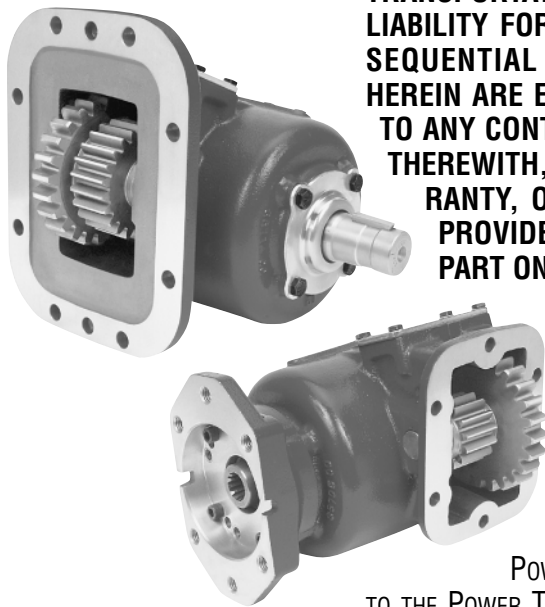

THE MUNCIE POWER TAKE-OFF IS WARRANTED TO BE FREE OF DEFECTS IN MATERIAL OR WORKMANSHIP AND TO MEET MUNCIE'S STANDARD WRITTEN SPECIFICATIONS AT THE TIME OF SALE. MUNCIE'S OBLIGATION AND LIABILITY UNDER THIS WARRANTY IS EXPRESSLY LIMITED TO REPAIRING OR REPLACING, AT MUNCIE'S OPTION, WITHIN ONE YEAR AFTER DATE OF ORIGINAL INSTALLATION ANY DEFECTIVE PART OR PARTS OR ANY PRODUCT NOT MEETING THE SPECIFICATIONS.

THIS WARRANTY IS IN LIEU OF ALL OTHER WARRANTIES, EXPRESSED OR IMPLIED. MUNCIE MAKES NO WARRANTY OF MERCHANTABILITY OR OF FITNESS FOR ANY PARTICULAR PURPOSE. MUNCIE'S OBLIGATION UNDER THIS WARRANTY SHALL NOT INCLUDE ANY TRANSPORTATION CHARGES OR COSTS OF INSTALLATION OR ANY LIABILITY FOR DIRECT, INDIRECT, SPECIAL, INCIDENTAL, OR CONSEQUENTIAL DAMAGES OR DELAY. THE REMEDIES SET FORTH HEREIN ARE EXCLUSIVE, AND MUNCIE'S LIABILITY WITH RESPECT TO ANY CONTRACT OR SALE OR ANYTHING DONE IN CONNECTION THEREWITH, WHETHER IN CONTRACT, IN TORT, UNDER ANY WARRANTY, OR OTHERWISE, SHALL NOT, EXCEPT AS EXPRESSLY PROVIDED HEREIN, EXCEED THE PRICE OF THE PRODUCT OR PART ON WHICH SUCH LIABILITY IS BASED.

IF REQUESTED BY MUNCIE, PRODUCTS OR PARTS FOR WHICH A WARRANTY CLAIM IS MADE ARE TO BE RETURNED TRANSPORTATION PREPAID TO A MUNCIE SERVICE CENTER. ANY INSTALLATION OR USE NOT IN ACCORDANCE WITH CATALOG OR PACKAGE INSTRUCTIONS, OTHER IMPROPER USE, OPERATION BEYOND CAPACITY, SUBSTITUTION OF PARTS NOT APPROVED BY MUNCIE, USE WITH EQUIPMENT OTHER THAN THE EQUIPMENT ON WHICH THE POWER TAKE-OFF IS FIRST INSTALLED, OR ALTERATION OR REPAIR MADE TO THE POWER TAKE-OFF OTHER THAN AT A MUNCIE SERVICE CENTER, SHALL VOID THIS WARRANTY. NO EMPLOYEE OR REPRESENTATIVE OF MUNCIE IS AUTHORIZED TO CHANGE THIS WARRANTY IN ANY WAY OR TO GRANT ANY OTHER WARRANTY.

Distributed By:



MP96-07 Printed in the U.S.A.
© Muncie Power Products, Inc. 1996

Muncie Power Products, Inc. Member of the Interpump Hydraulics Group
General Offices and Distribution Center • P.O. Box 548 • Muncie, IN 47308-0548
(765) 284-7721 • FAX (765) 284-6991 • E-mail info@munciepower.com
Web site <http://www.munciepower.com>

Drive Products, Inc., Toronto, Exclusive Agents for Canada, a Non-ISO Registered Firm

