



INSTALLATION NOTES

1. Disconnect negative battery cables from the batteries located underneath the passenger side cab step. Remove the right (passenger) side inner fender. Remove the O.E.M. serpentine belt, tensioner and the idler at location "E".
2. If the vehicle has an automatic transmission, remove the two transmission coolant lines from the radiator and move them aside. A small amount of transmission fluid will run out of the cooler.
3. Remove the two bolts at locations "A & B" from the tensioner bracket, and the rear motor mount bolt at location "C". Install the bracket onto the engine with bolt (4) at location "A", (4a) at location "B" with lockwashers (5) and bolt (6) with lockwasher (7) at location "C". Tighten all three bolts evenly, then torque bolts (4) and (4a) to 40ft/lbs., and bolts (6) to 75 ft/lbs..
4. Install the pump into the bracket with bolts (11), lockwasher (12) and nuts (13). Install the coil adapter plate (14) with bolts (15). Install the coil and clutch as per manufacturer's instructions. Install adapter (8) at the OEM tensioner location with bolt (9). Install the OEM idler onto adapter (8). Adapter (8) is designed to pivot so that maximum tensioner travel can be obtained. Install tensioner (2) onto the bracket with bolt (3). Install the belt (5061223) with single alternator according to the diagram.
5. ***AUTOMATICS ONLY:*** If equipped with an automatic transmission, the coolant hoses will need to be cut and rerouted to clear the hydraulic pump. Using a tubing cutter (not a hacksaw), cut the lower coolant tube approximately 3 inches from the radiator and install the compression fitting with hose barb adapter supplied in the kit. Install the 4 ft. piece of 5/8 oil hose and route it around the pump to a suitable location to connect it to the other end of the coolant line. Cut the steel tube at that location and install the compression with the hose barb. Connect the hose and secure it with the lomb claps provided. Cut the upper coolant hose approx. 3 inches from the 90° bend after it turns down. Install the compression fitting and hose barb. Install the 5/8 oil hose and run it down under the frame rail. Cut the transmission coolant hose under the radiator and connect the two ends together with the double ended hose barb provided in the kit. Secure the hose with the lomb claps provided.
6. Replace the fenderwell and connect the batteries. Run the engine and check for proper belt tracking and tension.

CAUTION: Check all engine compartment hoses that may have been disturbed or rerouted during kit installation to be sure hoses are not kinked, that they do not touch any high temperature item, and that they do not touch any moving components.

NOTE: This kit is designed to operate successfully with the standard fan supplied by the manufacturer of your truck. Due to O.E.M. assembly tolerances and change, visually make certain that there is adequate clearance between fan and drive pulley and fan to radiator. It may be necessary to use a different spacer for clearance.

CMKC03-662M-YP6-AC

2003 CHEVY

C-4500,5500

6.6 Diesel

W-WO/AC, W/ Dual Alt.

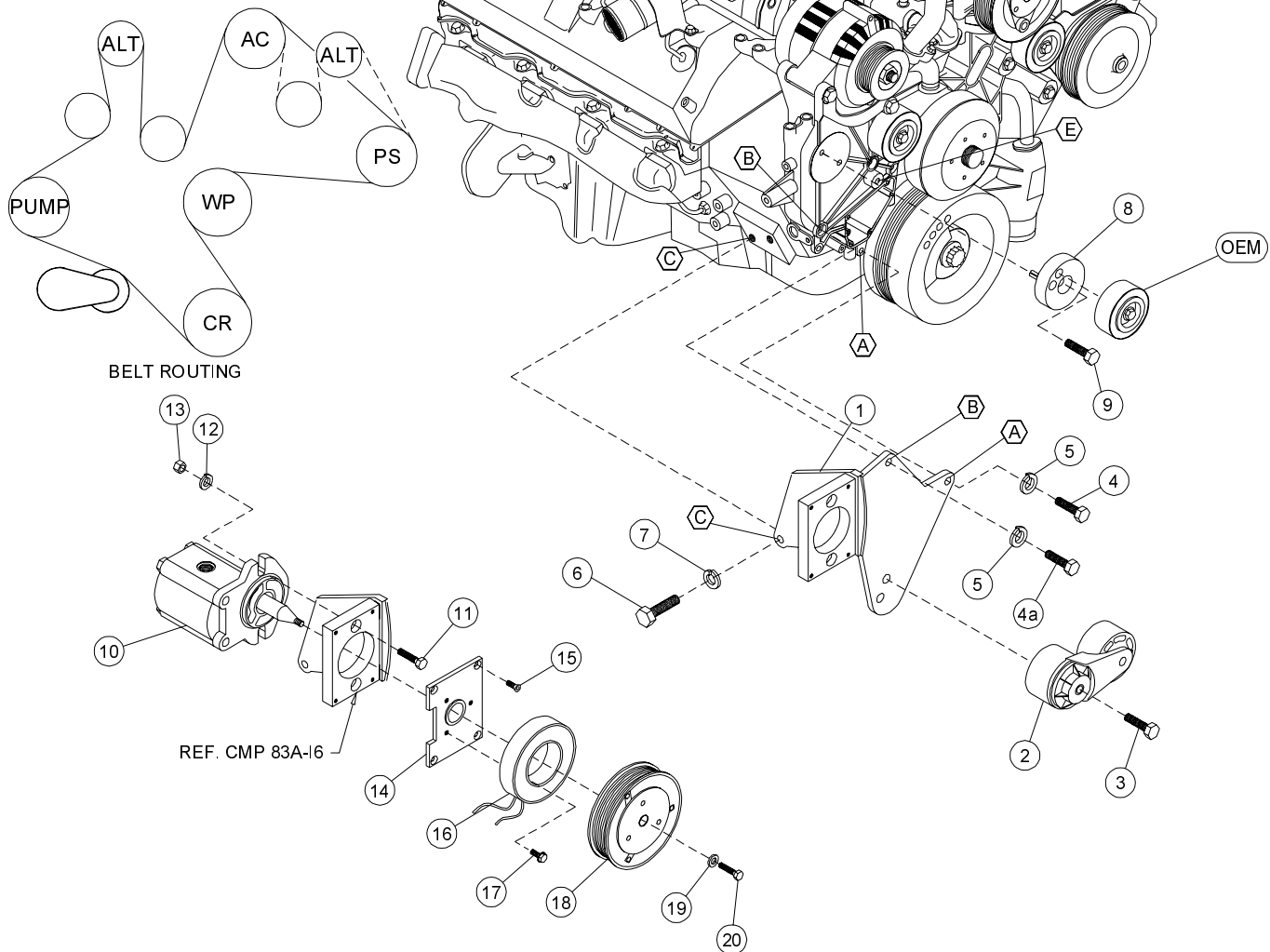

PARTS LIST

- | | |
|-----------------------------------|--|
| 1. CMP 83A-I6 (1) | 15. 1/4 x 3/4 NC FHSCS (4) |
| 2. Tensioner, Dayco 89200-B (1) | 16. Coil (Sold Separately) |
| 3. 10mm X 80 (1) | 17. Capscrew-19T34530 (3) (T=8-10 ft/lbs) |
| 4. 10mm X 90 (1) | 18. Clutch (Sold Separately) |
| 4a. 10mm X 100 (1) | 19. Flat Washer-21MZ3487 (1) |
| 5. 10mm LW (2) | 20. Capscrew-19T38756 (1) (T= 20 ft/lbs) |
| 6. 12mm X 80 (1) | <i>Following items not shown:</i> |
| 7. 12mm LW (1) | 21. w/dual alt. use belt: 5061380 Dayco(1) |
| 8. CMB830-I6 (1) | 22. 5/8 Hose Barb to JIC (3) |
| 9. 10mm X 25 (1) | 23. 5/8 Compression sleeve (3) |
| 10. Clutch Pump (Sold Separately) | 24. 5/8 Compression Nut (3) |
| 11. 3/8 x 1-1/2 NC (2) | 25. 5/8 Double Ended Hose Barb (1) |
| 12. 3/8 LW (2) | 26. #14 Adel Clamps (5) |
| 13. 3/8 NC Nut (2) | 27. #10 Hose Clamps (5) |
| 14. MCA01 plate | 28. 7' 5/8 Oil Hose |