



INSTALLATION NOTES

1. Disconnect negative battery cables from the batteries located underneath the passenger side cab step. Remove the right (passenger) side inner fender. Drain the engine coolant completely. Remove the top half of the fan shroud and remove the fan. (Fan nut has right hand threads). It is advisable to place a piece of cardboard over the radiator to protect it from damage during assembly. Remove the O.E.M. serpentine belt.
2. Remove the bolt holding the harmonic balancer on the crankshaft. It will be necessary to remove the rubber plug from the bottom of the transmission bell housing and use a pry bar or other suitable tool against the flywheel to keep the engine from turning while loosening the balancer bolt. Discard the thick balancer bolt washer and install the bolt into the drive pulley (10). Install the pulley onto the balancer, making sure the pilot is engaged into the balancer hole properly. Tighten the bolt finger tight, then looking from the front of the engine, turn the pulley in a counter clockwise direction until it hits the stop. Torque the balancer bolt to 278ft/lbs. (363 N-M). Install the rubber plug back into the transmission bell housing.
3. Remove the lower radiator hose at the radiator. Cut approximately 3 to 3 1/2" from the hose and install it back onto the radiator, reuse the OEM clamp.
4. If the vehicle has an automatic transmission, remove the two transmission coolant lines from the radiator and move them aside. A small amount of transmission fluid will run out of the cooler.
5. Remove the bolt from the alternator bracket at location "B" and the rear motor mount bolt at location "C". Install the pump bracket (1) onto the engine with bolt (4), lockwasher (5), and spacer (8) at location "A", bolt (4) and spacer (9) at location "B", and bolt (6) with lockwasher (7) at location "C". Tighten bolts evenly, then torque bolts (4) to 40 ft/lb(54 N-M), and bolt (6) to 75 ft/lb(102 N-M).
6. Install the pump onto the pump bracket with bolts (11), lockwashers (12), and nuts (13). Tighten bolts securely. Install the coil adapter plate (14) to the front of bracket (1) using bolts (15). Install the coil (16) and clutch (18) as per manufacturers instructions. Install the tensioner (2) onto the bracket with bolt (3). It may be necessary to trim the fan shroud slightly to clear the tensioner. Replace the O.E.M. serpentine belt, then install the pump drive belt. Install the fan spacer (9), fan and fan shroud. (Be sure to remove the cardboard from the radiator if it was used).
7. ***AUTOMATICS ONLY:*** If equipped with an automatic transmission, the coolant hoses will need to be cut and rerouted to clear the hydraulic pump. On model 2004 trucks use a tubing cutter (not a hacksaw), cut the lower coolant tube approximately 3 inches from the radiator and install the compression fitting with hose barb adapter supplied in the kit. Install the 4 ft. 8 in. piece of 5/8 oil hose and route it around the pump to a suitable location and connect it to the other end of the coolant line. Cut the steel tube at that location and install the compression with the hose barb. Connect the hose and secure it with the Adel clamps provided. Cut off any extra hose not needed and discard. On model 2005 and later trucks use tubing cutter (not a hacksaw), cut lower coolant tube on transmission end 2 1/2 inches below 90° bend and install on radiator. Cut straight end 2 1/2 inches from radiator end and install 90° hose barb compression fitting install this to transmission. Install the 4 ft. 8 in. piece of 5/8 oil fose and route it around the pump to a suitable location and connect both ends to hose barbs. Cut off any extra hose and discard. On all model trucks cut the upper coolant hose approx. 3 inches from the 90° bend after it turns down. Install the compression fitting and hose barb. Install the 5/8 oil hose and run it down under the frame rail. Cut the transmission coolant hose under the radiator and connect the two ends together with the double ended hose barb provided in the kit. Secure the hose with the Adel clamps provided.
8. Replace the engine coolant, and top off the transmission fluid if needed. Check for any leaks after the fluids have been replaced. Run the engine and check for proper clearances to moving parts and adjust belt tracking if necessary.

NOTE: Check all engine compartment hoses that may have been disturbed or rerouted during kit installation to be sure hoses are not kinked, that they do not touch any high temperature item, and that they do not touch any moving components.

NOTE: This kit is designed to operate successfully with the standard fan supplied by the manufacturer of your truck. Due to O.E.M. assembly tolerances and changes, visually make certain that there is adequate clearance between fan and drive pulley and fan to radiator. It may be necessary to use a different spacer for clearance.

CMKC06-660M-ZP8-AC

01/04-Current GMC & Chevy

6.6L Diesel Duramax

C-4500,5500

W-W/O AC, W-W/O Dual Alt.

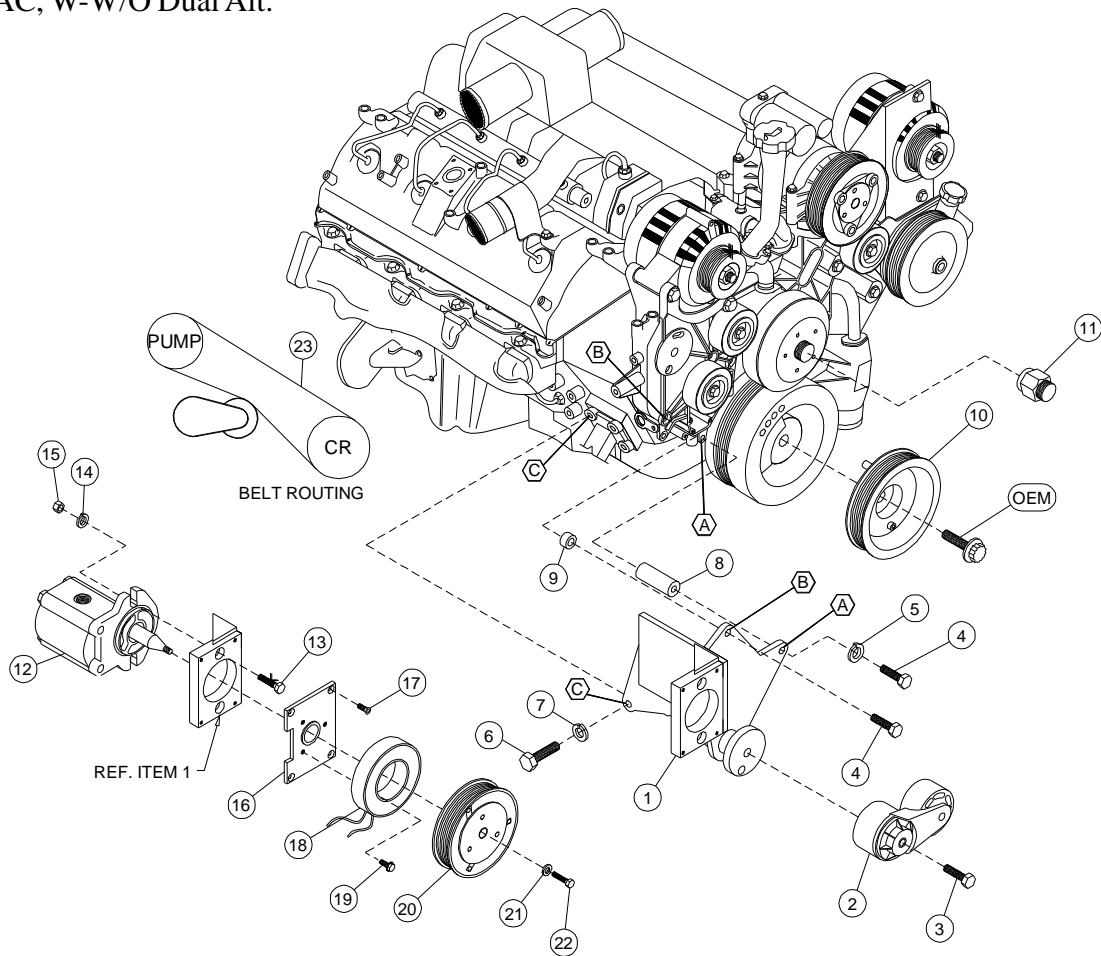

PARTS LIST

- | | | |
|-------------------------------|-------------------------------------|------------------------------------|
| 1. CMP 84A-8 (1) | 13. 3/8 X 1 1/2 NC (2) | 23. 5080565 Dayco Belt (1) |
| 2. Tensioner,Dayco 89200B (1) | 14. 3/8 LW (2) | <i>Following items not shown:</i> |
| 3. 10mm X 80mm (1) | 15. 3/8 NC (2) | 24. 5/8 Hose Barb to JIC (3) |
| 4. 10mm X 90mm (2) | 16. MCA01 (1) | 25. 5/8 Compression sleeve (4) |
| 5. 10mm LW (1) | 17. 1/4 X 3/4 NC FHSCS (4) | 26. 5/8 Compression Nut (4) |
| 6. 12mm X 80 (1) | 18. Coil (<i>Sold Separately</i>) | 27. 5/8 Double Ended Hose Barb (1) |
| 7. 12mm LW (1) | 19. Capscrew 19T34530 (3) | 28. #14 Adel Clamps (4) |
| 8. SP 100-2.650 | 20. Clutchpulley | 29. #10 Hose Clamps (4) |
| 9. SP 88-.475 | (<i>Sold Separately</i>) | 30. 7' 5/8 Oil Hose |
| 10. CPC 668B (1) | 21. Flat washer-21MZ3487 (1) | 31. 5/8 90° Hose Barb (1) |
| 11. FSK 6.8 (1) | 22. Capscrew 19T38756 (1) | 32. 1/2 Pipe to JIC (1) |
| 12. Clutch Pump Assembly | (T=20ft/lbs.) | |
| (<i>Sold Separately</i>) | | |