



**Muncie®  
Power  
Products**

**CMKC19-66MD-YP6-AC**

2019-2026 Chevrolet Silverado 4500HD-6500HD

2019-2026 International CV515

6.6L V8 Duramax Diesel w/ A/C, w/o Dual Alternators

Requires 6-Groove Clutch, SAE Two Bolt 'A' Flange Pump

Recommended 1.75 in.<sup>3</sup> or 8 gal. Pump w/ 12hp Restriction

**NOTE: Must Use Side Ported Pump**

## INSTALLATION NOTES

---

1. The buyer is responsible for providing trained and experienced installation decision making with technical know-how to apply professional judgment that specifically applies to each individual installation.
2. Be sure to read and understand all available information including but not limited to instructions, warnings, sale terms, and warranties for the vehicle and all system components prior to attempting installation.
3. Disconnect the batteries.
4. Disconnect the fan wire and remove the fan wire standoff at the rubber grommet. Discard the fan wire standoff. See Detail B.
5. Remove both OEM belts.
6. Install main bracket (1) with bolt (2) at mounting location [A] and bolts (3) at mounting location [B].
7. Install the clutch pump assemblies according to manufacturers' specifications onto the main bracket (1). Use clutch pump mounting hardware (8-16) to do so.
8. Install belt (12). Route it according the belt diagram. With the tensioner completely loaded, install the smooth idler pulley assembly (4-7) into the lowest hole it can be installed in. Release the tensioner.
9. Install the OEM 8-groove fan belt. Reconnect the fan wire.
10. Reconnect the batteries.

**CAUTION:** Before starting the engine. Check to make certain no wires, hoses, etc. that may have been disturbed during installation do not come in contact with any hot or moving parts. Run the engine and check for proper belt tracking, adjust if necessary.

Disclaimer: (1.) Due to the custom nature and variation of all add-on systems of this type, no complete system kits are offered by the manufacturer, and any group of parts marketed as a kit is limited to only the individually defined parts in that specific kit. The system designer's rotating accessory components are not included, offered, or fully known by the manufacturer. In addition to the absence of the rotating accessory system, other potential components such as additional clamps, brackets, wear liners, hardware, or other items that may be required by the system designer must be identified and supplied by the actual system designer. (2.) Due to vehicle manufacturer's assembly tolerances, production changes, and installation variances, it is the buyer's responsibility to ensure adequate clearance for all components including space for and safe location of the fan, radiator, all lines, and wires. Check for possible movement, vibration, friction points, heat exposure and/or shifting of any and all components such as hoses, wires, and all other components including those that may otherwise be considered non-moving and/or unaffected by the installation (3.) The buyer is responsible for the entire installation of a mounting kit as the mounting kit is part of a custom process controlled by the buyer through their whole system design and directed installer as the installer evaluates, locates, routes, aligns, and tightens all components while determining if additional clamps, brackets, wear-liners, or other components may be required, beyond those included in the kit. Any additional items required, beyond those included in the kit, are to be provided at the expense of the buyer. (4.) The buyer is responsible for the development and communication of their whole system installation procedures, safety precautions, application, and use of the engine accessory mounting kit in their system, including efforts to maintain vehicle control and prevent pinch, wear, impact, and/or burn exposure on all hoses, wires, and other parts. (5.) The buyer is responsible for providing trained and experienced installation decision making with technical know-how to apply professional judgment that specifically applies to each individual installation. The buyers chosen installers must be qualified and experienced technicians that are familiar with the vehicle and accessory being mounted as well as the buyer's whole system design and installation procedures associated with the kit. (6.) The buyer is responsible for determining and achieving compliance to all regulatory issues that apply to the use of all products. (7.) The manufacturer reserves the right to make changes and/or improvements to any product at any time with or without notice.



# Muncie® Power Products

## CMKC19-66MD-YP6-AC

2019-2026 Chevrolet Silverado 4500HD-6500HD

2019-2026 International CV515

6.6L V8 Duramax Diesel w/ A/C, w/o Dual Alternators

Requires 6-Groove Clutch, SAE Two Bolt 'A' Flange Pump  
Recommended 1.75 in.<sup>3</sup> or 8 gal. Pump w/ 12hp Restriction

**NOTE: Must Use Side Ported Pump**

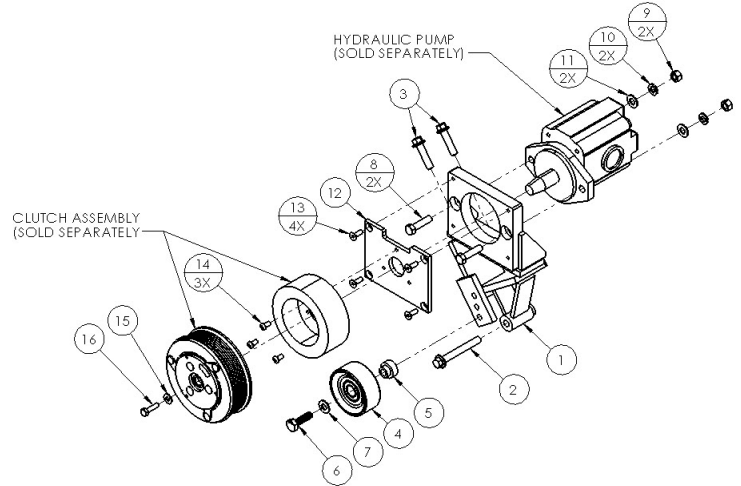
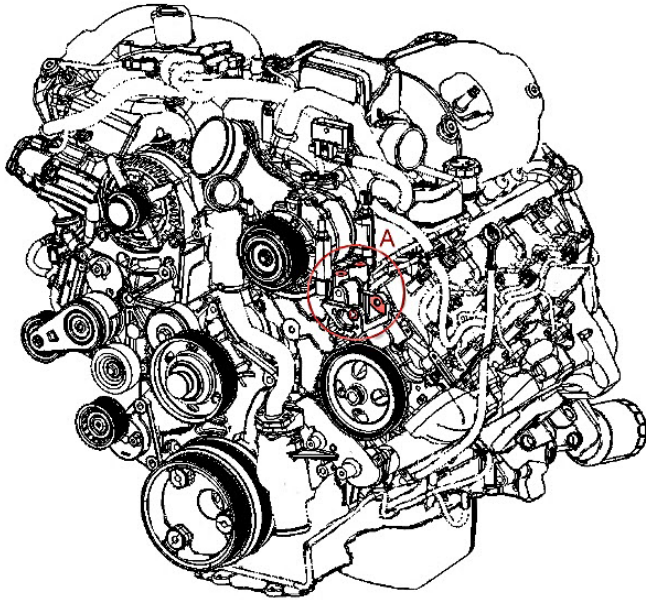

MOUNT  
LOCATION B

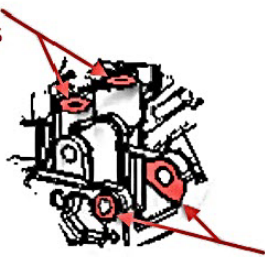

DETAIL A

MOUNT  
LOCATION A

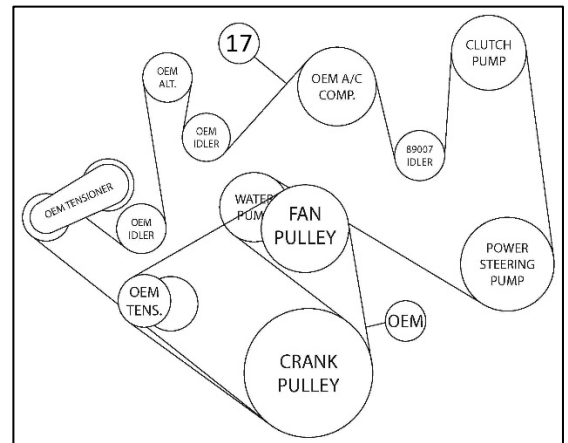

Belt Routing (17)

Detail A: Engine Mounting Locations [A,B]

PARTS LIST							
Item	Part Number	Description	Qty.	Item	Part Number	Description	Qty.
<b>Main Bracket</b>				10	1010315	3/8" Lock Washer	2
1	CMB262A	Main Bracket	1	11	1007644	3/8" Flat Washer	2
<b>Main Bracket Mounting Hardware</b>				12	MCA01	Coil Adapter Plate	1
2	1006928	M10-1.5 x 80mm Flange Bolt	1	13	1007577	1/4"-20 x 3/4" NC FHSCS	4
3	1006933	M10-1.5 x 40mm Flange Bolt	2	14	19T34530	Caps crew (T=8-10 ft/lbs) (Comes w/ Clutch)	3
<b>Smooth Idler Pulley Assembly</b>				15	21MZ3487	Flat Washer (Comes w/ Clutch)	1
4	89007	Dayco Smooth Idler Pulley	1	16	19T38756	Caps crew (T=20 ft/lbs) (Comes w/ Clutch)	1
5	CMB3867	Machined Idler Bushing	1	<b>Belt</b>			
6	1007566	M10-1.5 x 35mm Bolt	1	17	5061380	Dayco 6-Grooves 138.0" Belt	1
7	1007644	3/8" Flat Washer	1				
<b>Clutch Pump Mounting Hardware</b>							
8	1005139	3/8"-16 x 1-1/2" NC Bolt	2				
9	1010314	3/8"-16 NC Nut	2				



**Muncie<sup>®</sup>**  
**Power**  
**Products**

# CMKC19-66MD-YP6-AC

2019-2026 Chevrolet Silverado 4500HD-6500HD

2019-2026 International CV515

6.6L V8 Duramax Diesel w/ A/C, w/o Dual Alternators

Requires 6-Groove Clutch, SAE Two Bolt 'A' Flange Pump

Recommended 1.75 in.<sup>3</sup> or 8 gal. Pump w/ 12hp Restriction

**NOTE: Must Use Side Ported Pump**

## Detail B

Remove standoff and discard per

Installation note 4.

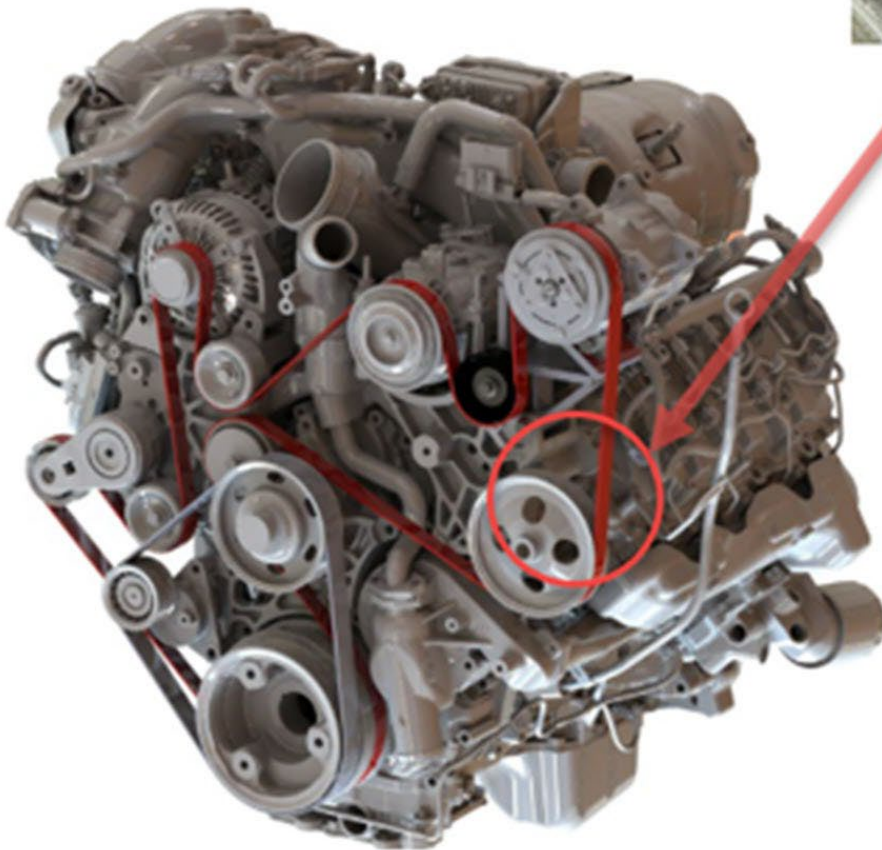

Detail B: Wire Standoff Removal and Discard