



**Muncie®  
Power  
Products**

**CMKC20-660G-P6-AC**

2020-2026 Chevrolet Silverado 2500HD-3500HD

2020-2026 GMC Sierra 2500HD-3500HD

6.6L V8 Gas w/-w/o A/C, w/o Dual Alternators

Requires 6-Groove Clutch, Muncie PH Series Foot-Mount Pump

Recommended 1.75 in.<sup>3</sup> or 8 gal. Pump w/ 12hp Restriction

NOTE: Must use Rear Ported Pump

## INSTALLATION NOTES

---

1. The buyer is responsible for providing trained and experienced installation decision making with technical know-how to apply professional judgment that specifically applies to each individual installation.
2. Be sure to read and understand all available information including but not limited to instructions, warnings, sale terms, and warranties for the vehicle and all system components prior to attempting installation.
3. Disconnect negative battery cable. Remove upper fan shroud, air filter tube, and air deflector. Remove fan for easy access (Not required) (Fan has right-hand threads).
4. Remove OEM belt. Remove power steering pump bolts by going through pulley. Remove OEM power steering bracket. Save bolts for reinstall. Remove wire bracket and cut bracket as shown, reinstall.
5. Install studs (3) in engine block at mounting point [A]. Install main bracket (1) onto the engine block with three OEM power steering bracket bolts (2) mounting location [B] and nuts (4) at mounting location [A]. Install clutch pump assemblies according to manufacturer's instructions with mounting hardware (15-16). Install power steering pump using bolts (5) onto main bracket (1). Place small coolant hose behind power steering pump reservoir. Install smooth idler pulley assembly (6-9) and grooved idler pulley assembly (10-14) onto main bracket (1). Using zip ties (17), tie power steering hose and wires as shown.
6. Install new belt (18) as shown. Install fan and air deflector. Install fan shroud. It may be necessary to rotate upper radiator hose slightly for clearance. Connect battery cable.

**CAUTION:** Before starting the engine. Check to make certain no wires, hoses, etc. that may have been disturbed during installation do not come in contact with any hot or moving parts. Run the engine and check for proper belt tracking, adjust if necessary.

Disclaimer: (1.) Due to the custom nature and variation of all add-on systems of this type, no complete system kits are offered by the manufacturer, and any group of parts marketed as a kit is limited to only the individually defined parts in that specific kit. The system designer's rotating accessory components are not included, offered, or fully known by the manufacturer. In addition to the absence of the rotating accessory system, other potential components such as additional clamps, brackets, wear liners, hardware, or other items that may be required by the system designer must be identified and supplied by the actual system designer. (2.) Due to vehicle manufacturer's assembly tolerances, production changes, and installation variances, it is the buyer's responsibility to ensure adequate clearance for all components including space for and safe location of the fan, radiator, all lines, and wires. Check for possible movement, vibration, friction points, heat exposure and/or shifting of any and all components such as hoses, wires, and all other components including those that may otherwise be considered non-moving and/or unaffected by the installation (3.) The buyer is responsible for the entire installation of a mounting kit as the mounting kit is part of a custom process controlled by the buyer through their whole system design and directed installer as the installer evaluates, locates, routes, aligns, and tightens all components while determining if additional clamps, brackets, wear-liners, or other components may be required, beyond those included in the kit. Any additional items required, beyond those included in the kit, are to be provided at the expense of the buyer. (4.) The buyer is responsible for the development and communication of their whole system installation procedures, safety precautions, application, and use of the engine accessory mounting kit in their system, including efforts to maintain vehicle control and prevent pinch, wear, impact, and/or burn exposure on all hoses, wires, and other parts. (5.) The buyer is responsible for providing trained and experienced installation decision making with technical know-how to apply professional judgment that specifically applies to each individual installation. The buyers chosen installers must be qualified and experienced technicians that are familiar with the vehicle and accessory being mounted as well as the buyer's whole system design and installation procedures associated with the kit. (6.) The buyer is responsible for determining and achieving compliance to all regulatory issues that apply to the use of all products. (7.) The manufacturer reserves the right to make changes and/or improvements to any product at any time with or without notice.



# Muncie® Power Products

## CMKC20-660G-P6-AC

2020-2026 Chevrolet Silverado 2500HD-3500HD  
2020-2026 GMC Sierra 2500HD-3500HD  
6.6L V8 Gas w/-w/o A/C, w/o Dual Alternators

Requires 6-Groove Clutch, Muncie PH Series Foot-Mount Pump  
Recommended 1.75 in.<sup>3</sup> or 8 gal. Pump w/ 12hp Restriction  
**NOTE: Must use Rear Ported Pump**

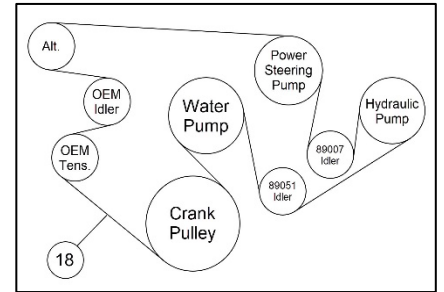

Belt Routing (18)

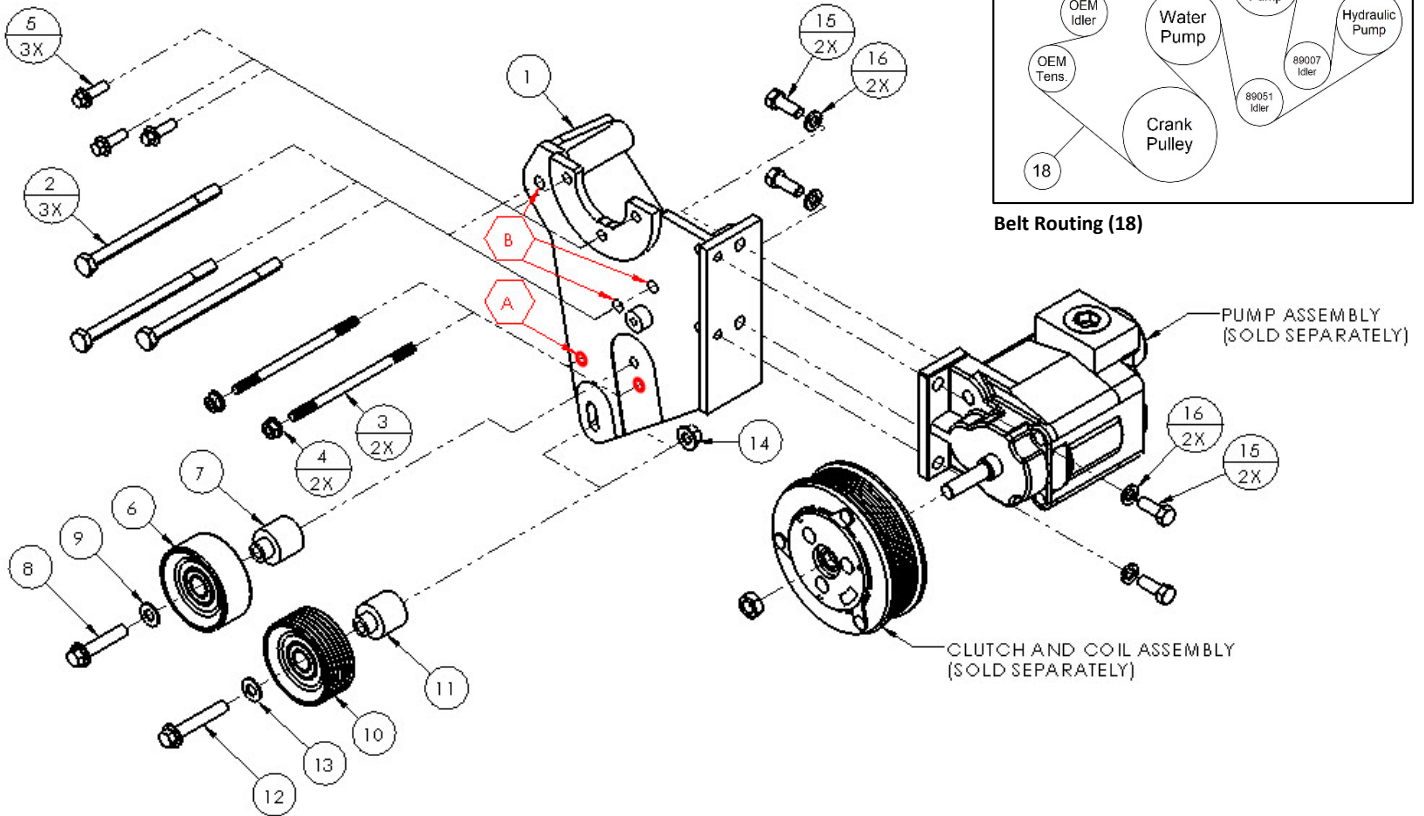

PARTS LIST							
Item	Part Number	Description	Qty.	Item	Part Number	Description	Qty.
<b>Main Bracket</b>				<b>Grooved Idler Pulley Assembly</b>			
1	CMB1401	Main Bracket	1	10	89051	Dayco Grooved Idler Pulley	1
<b>Main Bracket Mounting Hardware</b>				11	CMB140-2	Machined Idler Bushing	1
2	N/A	OEM Power Steering Bracket Bolts	3	12	1018229	M10-1.5 x 60mm Flange Bolt	1
3	1018292	M8-1.25 x 140mm Stud	2	13	1007644	3/8" Flat Washer	1
4	1013333	M8-1.25 Flange Nut	2	14	1018204	M10-1.5 Flange Nut	1
<b>Power Steering Pump Mounting Hardware</b>				<b>Clutch Pump Mounting Hardware</b>			
5	1011887	M8-1.25 x 25mm Flange Bolt	3	15	1005274	3/8"-16 X 1" NC Bolts	4
<b>Smooth Idler Pulley Assembly</b>				16	1002595	3/8" Lock Washers	4
6	89007	Dayco Smooth Idler Pulley	1	<b>Zip Ties</b>			
7	CMB140-1	Machined Idler Bushing	1	17	1010692	Small Zip Ties	3
8	1006934	M10-1.5 x 50mm Flange Bolt	1	<b>Belt</b>			
9	1007644	3/8" Flat Washer	1	18	5061223	Dayco 6-Groove 122.3" Belt	1



# Muncie® Power Products

## CMKC20-660G-P6-AC

2020-2026 Chevrolet Silverado 2500HD-3500HD

2020-2026 GMC Sierra 2500HD-3500HD

6.6L V8 Gas w/-w/o A/C, w/o Dual Alternators

Requires 6-Groove Clutch, Muncie PH Series Foot-Mount Pump

Recommended 1.75 in.<sup>3</sup> or 8 gal. Pump w/ 12hp Restriction

NOTE: Must use Rear Ported Pump

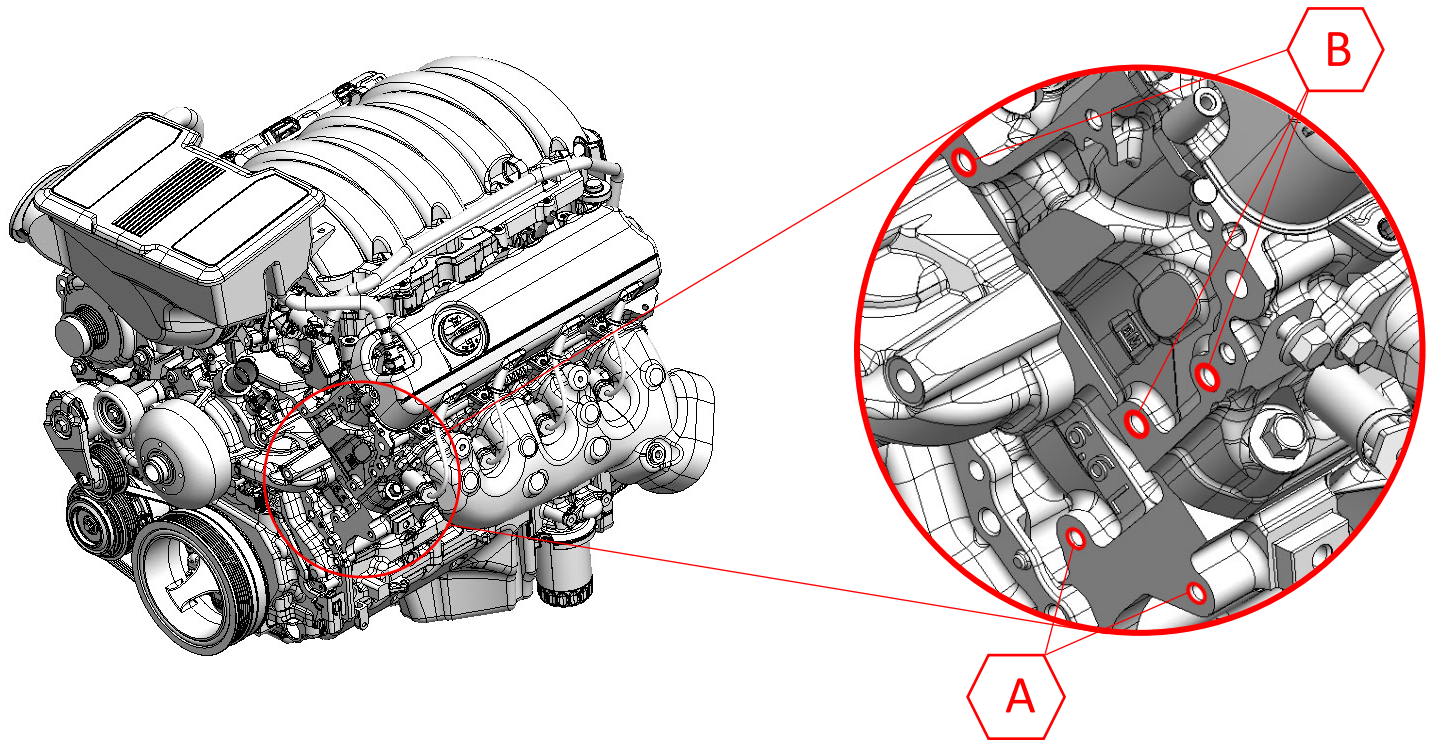

Engine Mounting Locations [A,B]

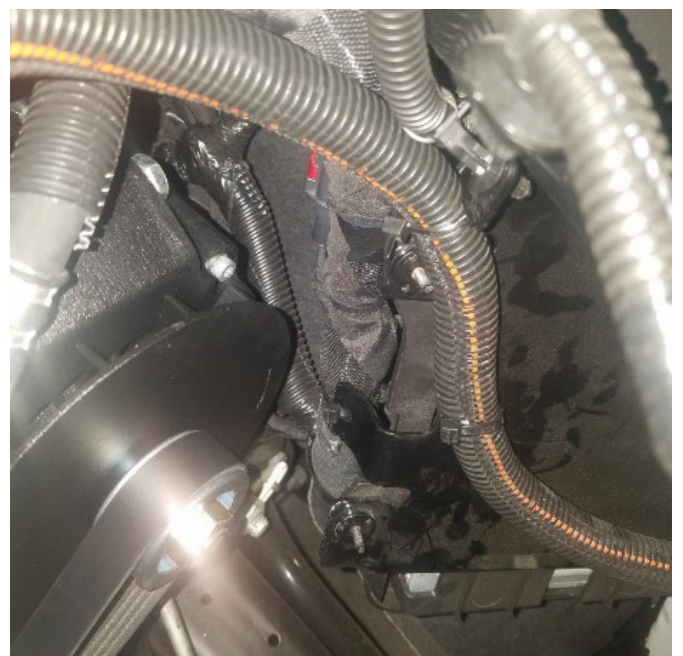

Wire Bracket Modifications, Three Small Zip Ties (17)