



**Muncie<sup>®</sup>  
Power  
Products**

**CMK C69-3540-A-AC**

**1973-83 CHEVY**

**C&K 10, 20, 30**

**305,350,400**

**W-WO/AC, A.I.R., PS**

### **INSTALLATION NOTES**

---

1. Disconnect battery terminal and belts. Mark fan to water pump pulley for proper re-installation, remove fan.
2. Remove bolts and washers from pulley on front of crankshaft. Install drive pulley (1) with provided bolts. **CAUTION:** Be sure to use the bolts with same thread as O.E.M. bolts removed.
3. Remove alternator from original position. Remove support bracket from back of alternator. Install alternator with top bolt only. Do not tighten bolt.
4. Remove A.I.R. pump and remove lower bolt sleeve as shown in diagram. Install A.I.R. pump with top bolt only. Do not tighten bolt. **NOTE:** Install bracket (13) if no A.I.R. pump is used.
5. Install mounting bracket (11) using provided spacers (14 & 15) and A.I.R. pump bolt (2 or 19) and alternator bolt (17). Do not tighten bolts.
6. Remove fan studs and replace with provided studs (8), install fan spacer (7). Install fan, align marks from step 1, tighten securely.
7. Install and tighten O.E.M. belts to specified tension. Tighten all loose bracket bolts.
8. Mount clutch pump (26) to pump plate. Make sure clutch pulley is in line with drive pulley (1). Tighten pump bolts securely. Install pump drive belts (25). Adjust mounting plate (12) for proper belt tension. Tighten bolts (18 & 20) on pump plate. Connect battery terminal.

**CAUTION:** Check all engine compartment vacuum hoses and electrical wiring that might have been disturbed or re-routed during kit installation to be sure that hoses are not kinked, that they do not touch any high temperature item, and that they do not interfere with any linkage components.

**NOTE:** Heater hoses and ram air tube may need to be re-routed or the length may need to be changed.

**NOTE:** This kit is designed to operate successfully with the standard fan supplied by the manufacturer of your truck. Due to O.E.M. assembly tolerances, visually make certain that there is adequate clearance between fan and drive pulley as well as between fan and radiator. It may be necessary to use a different fan spacer for clearance. If there is little clearance to the radiator, check with a Chevrolet dealership to insure that it will not flex into the radiator before operating. Move radiator if necessary. Fan shroud may need to be notched for belt clearance.

# CMKC69-3540-A-AC

1973-83 CHEVY 305, 350, 400

W-WO/AC, A.I.R., PS

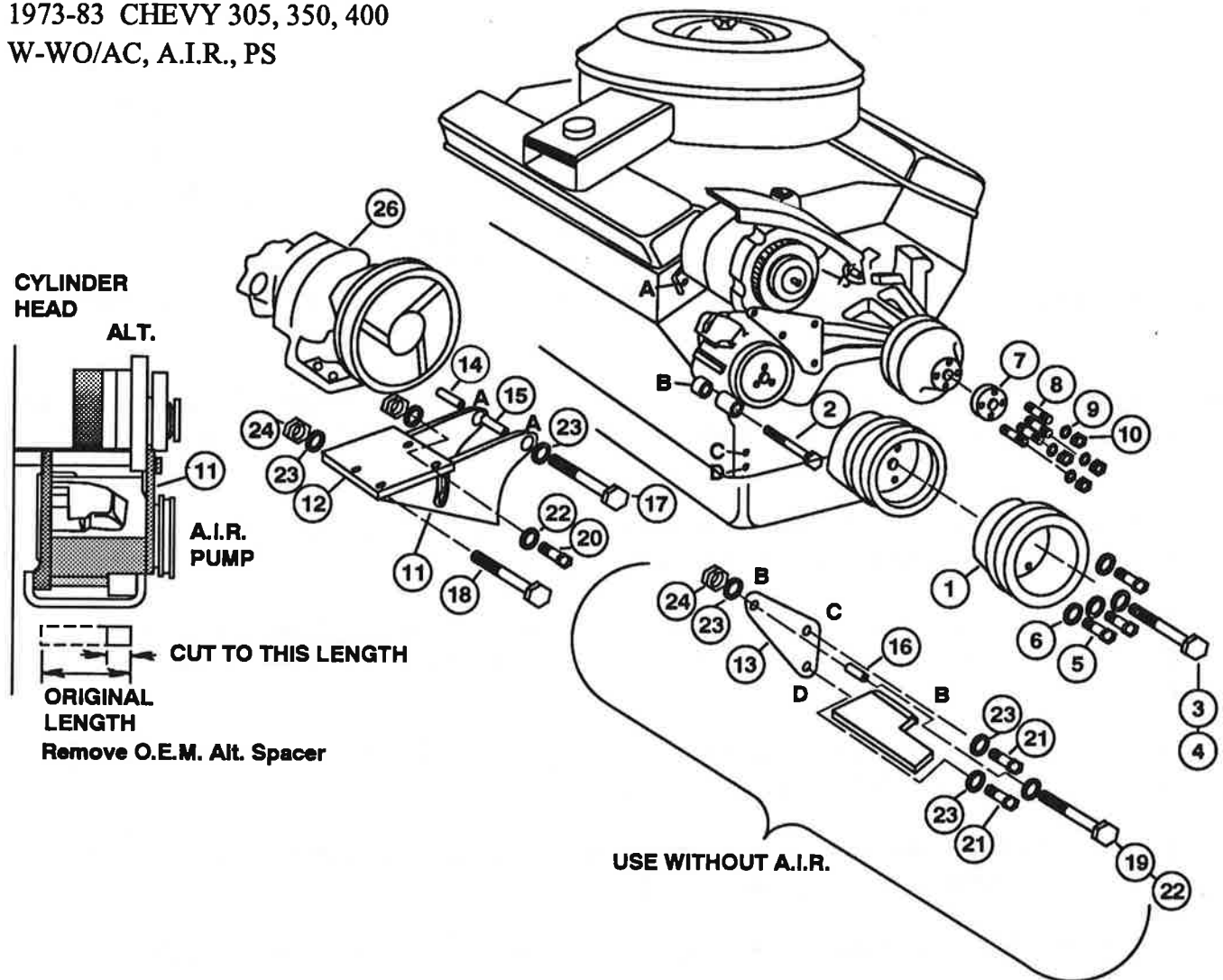

## PARTS LIST

- |                         |   |
|-------------------------|---|
| 1. CPC 312 (1)          | 14. SP64-1.625 (1)                                |
| 2. O.E.M.               | 15. SP64-1.375 (1)                                |
| 3. 7/16 X 3 NF (1)      | 16. SP64-0.500 (1)                                |
| 4. 7/16 LW (1)          | 17. 3/8 X 6-1/2 NC (1)                            |
| 5. 3/8 X 1-1/2 NF C (3) | 18. 3/8 X 5 NC (1)                                |
| 6. 3/8 LW (3)           | 19. 3/8 X 3-1/2 NC (1)                            |
| 7. FS0 504 (1)          | 20. 3/8 X 1-1/2 NC (1)                            |
| 8. 5/16 X 2 ST (4)      | 21. 3/8 X 1 NC (2)                                |
| 9. 5/16 LW (4)          | 22. 3/8 FW (2)                                    |
| 10. 5/16 NC (4)         | 23. 3/8 LW (6)                                    |
| 11. CMB 310 (1)         | 24. 3/8 NC (3)                                    |
| 12. CMP 311 (1)         | 25. AX-61 (2) (Not Shown)                         |
| 13. CMB 311 (1)         | 26. Clutch Pump Assembly (1)<br>(Sold Separately) |