



**Muncie[®]
Power
Products**

CMKC88-4500-A-AC
1988-93 CHEVY C&K-3500
454 W-WO/AC,
(Serpentine)

INSTALLATION NOTES

1. Disconnect battery terminal. Loosen serpentine belt, do not remove.
IMPORTANT: Mark fan flange to water pump pulley for proper re-installation. Remove fan and shroud.
2. Remove crankshaft pulley, install O.E.M. crankshaft pulley on pump drive pulley (1) to check fit. **IMPORTANT:** Due to variations in O.E.M. pulley make sure both pulleys fully seat together. Install drive pulley (1) with provided bolts and lockwashers.
CAUTION: Be sure bolts have the same threads as O.E.M. bolts removed, discard O.E.M. flatwasher.
3. Remove fan studs and replace with provided studs (7). Install fan spacer (6), fan and shroud.
IMPORTANT: Align marks from step 1. Tighten securely.
4. Remove bolts at locations "B & D". Do not remove bolt at location "C".
5. Install mounting bracket (10) using spacer (14) and bolts (15, 17 & 19).
NOTE: Power steering hose may be looped up in location of mounting bracket (10). If so, carefully re-route hose to gain clearance for bracket. It may be necessary to remove hose and reinstall around other power steering lines.
6. Remove bolt at location "C", install spacer (13) and bolt (17). Install brace (11) to bracket (10) and cylinder head at location "E". Tighten bolts at all locations "A-E". Tension serpentine belt.
7. Mount clutch pump (25) to pump plate (12). Make sure clutch pulley is aligned with drive pulley (1). Tighten pump bolts securely. Install pump drive belts (24), adjust pump plate (12) for proper belt tension, tighten bolts (17, 18 & 19). Connect battery terminal.

CAUTION: Check all engine compartment wiring, vacuum and power steering hoses that may have been disturbed or re-routed during kit installation. Be sure hoses are not kinked, do not contact any high temperature item, and do not interfere with any linkage components.

NOTE: Visually make certain that there is adequate clearance between fan and drive pulley and also between fan and radiator. It may be necessary to use a longer spacer for pulley clearance.

CMKC88-4500-A-AC

1988-93 CHEVY

454 W-WO/AC

(SERPENTINE)

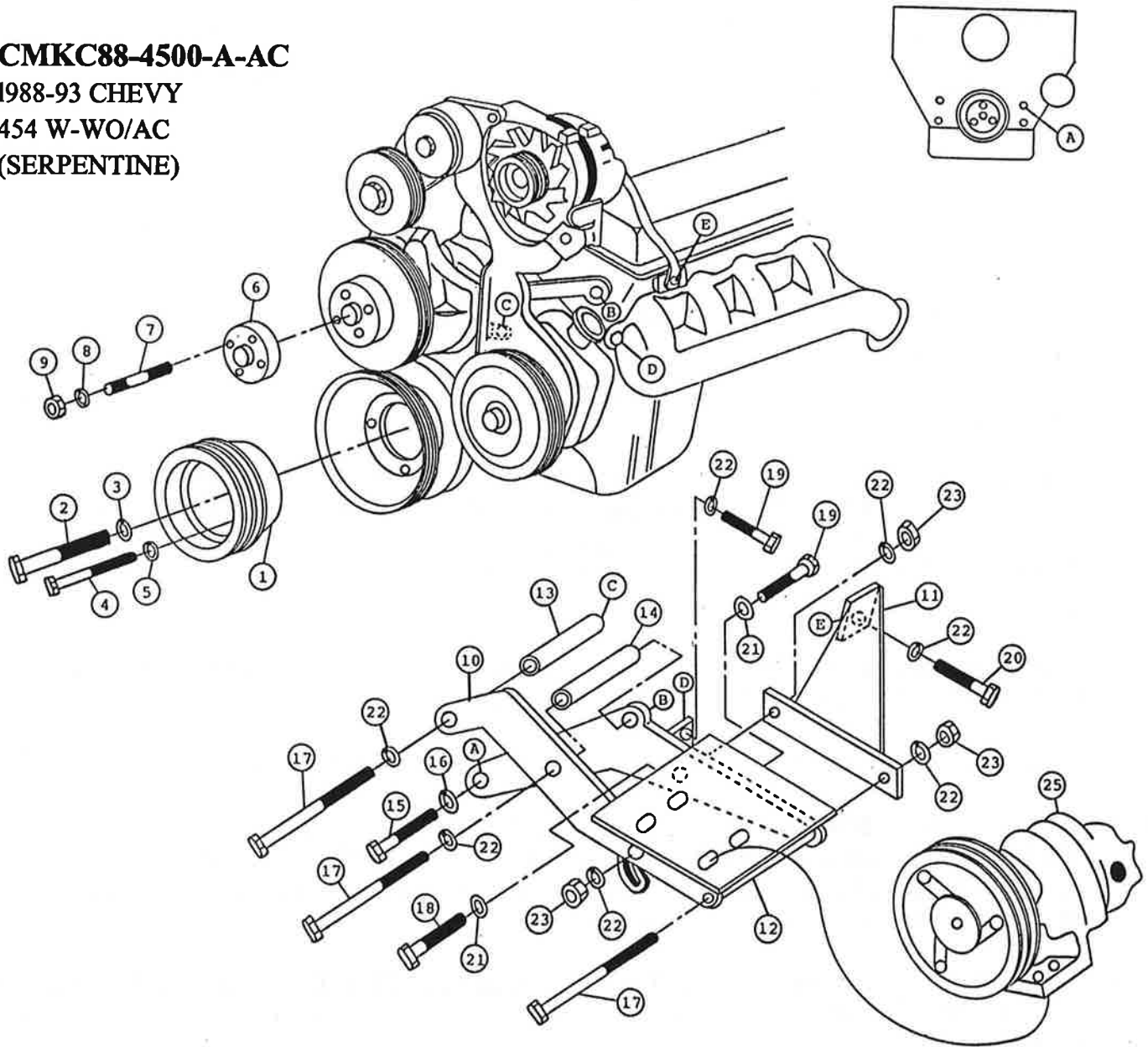

PARTS LIST

- | | |
|----------------------------|------------------------------|
| 1. CPC 432 (1) | 14. SP88-3.750 (1) |
| 2. 1/2 X 3 NF GR. 8 (1) | 15. 7/16 X 1-1/2 NC (1) |
| 3. 1/2 LW (1) | 16. 7/16 LW (1) |
| 4. 3/8 X 3 NC,NF GR. 8 (3) | 17. 3/8 X 5-1/2 NC (3) |
| 5. 3/8 LW (3) | 18. 3/8 X 1-3/4 (1) |
| 6. FSO 506 (1) | 19. 3/8 X 1-1/2 NC (2) |
| 7. 8mm X 45mm 1.25 ST (4) | 20. 3/8 X 1 NC (1) |
| 8. 8mm LW (4) | 21. 3/8 FW (2) |
| 9. 8mm 1.25 (4) | 22. 3/8 LW (7) |
| 10. CMB 430 (1) | 23. 3/8 NC (3) |
| 11. CMB 431 (1) | 24. AX-60 (2) (Not Shown) |
| 12. CMP 431 (1) | 25. Clutch Pump Assembly (1) |
| 13. SP88-4.312 (1) | (Sold Separately) |

NOTE: Upper radiator hose may need to be shortened 3/4 in. for clutch pump clearance.