



**Muncie[®]
Power
Products**

**CMKC91-3116-A
CMKC91-3116-AH
1990-02 CHEVY
C-60,70 Kodiak
CAT 3116,3126 WO/AC**

INSTALLATION NOTES

1. Disconnect positive battery terminal. Remove passenger side inner fenderwell, and ram air tube to air cleaner. Remove fan, threads are left hand. Loosen six bolts from fan idler pulley. If equipped with tensioner, remove serpentine belt by loosening spring tension idler using 1/2 in. drive ratchet. If not equipped with tensioner, loosen alternator to remove belt.
2. Remove fan idler pulley. Replace with drive pulley (1) using O.E.M. bolts. Be sure pulley is completely seated against idler flange and be careful not to over tighten bolts.
3. Remove four bolts holding serpentine tensioner at location "A-D", if equipped. Remove nut from alternator at location "F". Install lower bracket (2) around alternator and over tensioner.
NOTE: Use spacers (4) at "A-D" if not equipped with tensioner. Secure bracket at all locations.
4. Assemble pump plate (6) to lower bracket (2) with bolts (13). Be sure pump plate slides easily over lower bracket for easy belt adjustment. Install clutch pump (24) to pump plate (6) with bolts provided. Align clutch pump pulley to drive pulley (1), tighten pump bolts.
5. Install idler pulley (7) to pump plate with bolts (8) and shims (9 & 10), check alignment to drive pulley (1), secure idler.
6. Install pump drive belts (23).
NOTE: It may be necessary to remove metal tube from turbo to aftercooler in order to install belts. Using a 3/8 in. Torx or 7/16 in. 12 pt. socket, adjust tension bolt against tab on bracket (3) to proper belt tension, secure bolts (13).
7. Install metal turbo line if removed. Install fan securely. Clearance to inner fenderwell is minimal. It may be necessary to slightly spread front mounting location to ease assembly. It is necessary to leave ram air tube off air cleaner for clutch pump clearance.

CAUTION: Check all engine compartment vacuum hoses and electrical wiring that may have been disturbed or re-routed during kit installation to be sure that hoses are not kinked, that they do not touch any high temperature items, and that they do not interfere with any linkage components.

CMKC91-3116-A
CMKC91-3116-AH
 1990-02 Chevy
 C-60,70 Kodiak
 CAT 3116,3126 WO/AC

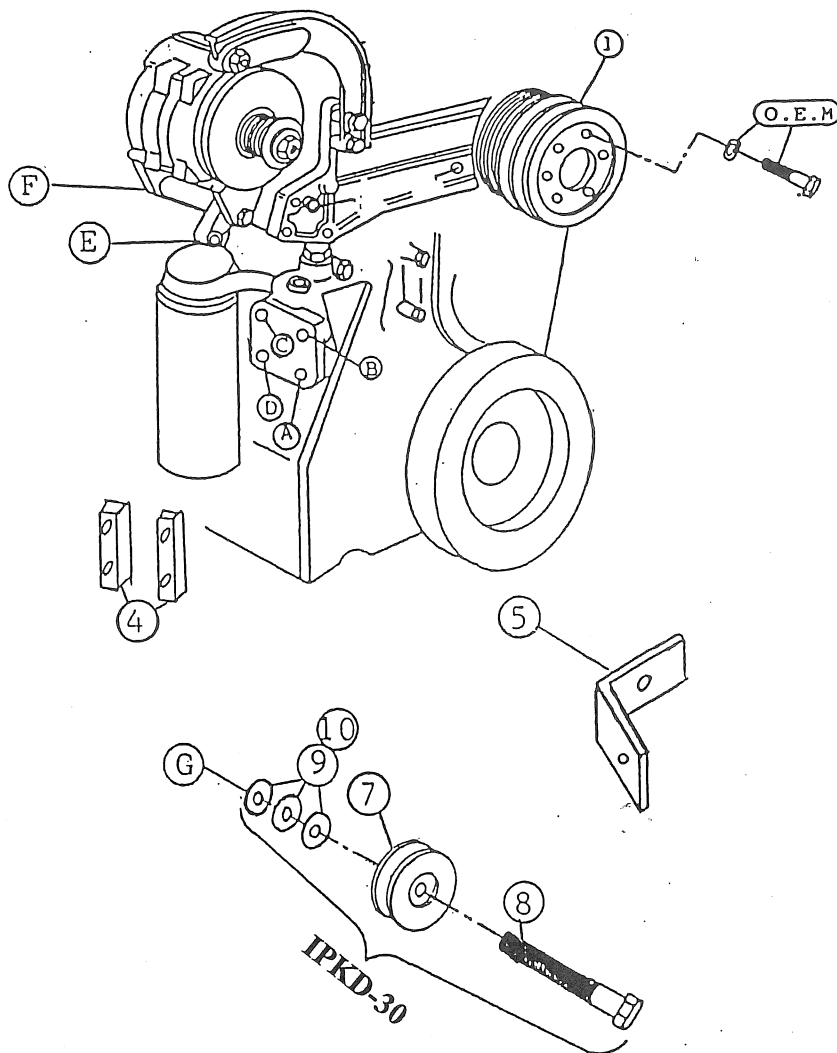
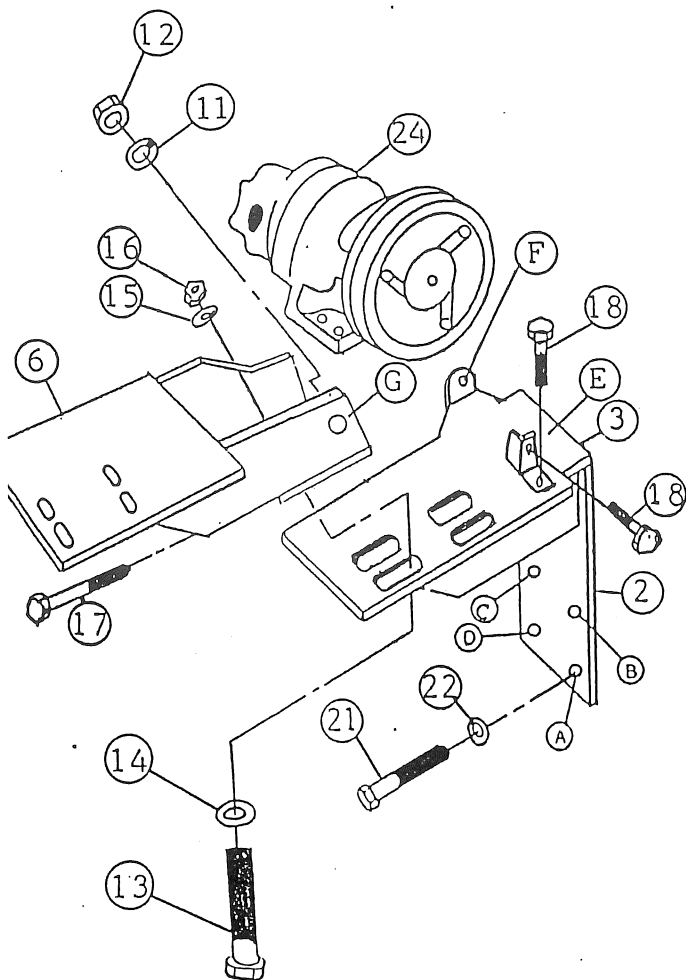

PARTS LIST

- | | |
|-------------------|--|
| 1. CPC 712 (1) | 13. 1/2 X 1 3/4 NC (4) |
| 2. CMB 721 (1) | 14. 1/2 FW (4) |
| 3. CMB 722 (1) | 15. 1/2 LW (4) |
| 4. CMB 723 (2) | 16. 1/2 NC (4) |
| 5. CMB 724 (1) | 17. 3/8 X 3 1/2 SQ. Set Screw (2) |
| 6. CMP 721 (1) | 18. 3/8 X 1 3/4 NC GR. 8 (2) |
| 7. IPCD (1) | 19. 3/8 LW (2) |
| 8. 5/8 X 3 NC (1) | 20. 3/8 NC (2) |
| 9. IPW14 (5) | 21. 8mm X 50mm 1.25, 10.9 (4) |
| 10. 5/8 FW (5) | 22. 8mm LW (4) |
| 11. 5/8 LW (1) | 23. A62F (2) H.D.: A64F (Not Shown) |
| 12. 5/8 NC (1) | 24. Clutch Pump (1)
(Sold Separately) |

NOTE: Small angle bracket (5) is provided to move a metal hydraulic line closer to radiator for clutch clearance, if necessary.

NOTE: Bracket (2) goes **OVER** belt tensioner bracket at locations "A-D". Use spacers (4) **WITHOUT** belt tensioner at locations "A-D".