



**Muncie[®]
Power
Products**

**CMKC95-6500-A-AC
CMKC95-6500-AH-AC**

**1988-95 CHEVY
C & K 1500,2500,3500
6.2,6.5 Diesel W-WO/AC
(Serpentine)**

INSTALLATION NOTES

1. Disconnect battery cable(s) at battery(s). **IMPORTANT:** Mark fan flange and water pump pulley for proper re-installation. Remove upper half of fan shroud, fan, serpentine belt, and belt tensioner.
2. Remove bolts and washers from crankshaft pulley. Install drive pulley (1) with provided bolts (2) and washers (3). **CAUTION:** Make certain the new bolts are the same thread as the O.E.M. bolts removed.
3. Install spacer nuts (12) over nuts at position "A & B". Remove upper water pump bolt at location (C). Remove alternator bolt at location (D). Install bracket (8) with bolt (13), lockwasher (16) and spacer (11) at location "C". Use bolts (14) and lockwasher (16) at locations "A & B". Install new alternator bolt (17) spacer (11a) and nut (21) in location "D". Do not tighten.
4. Remove bolts from brace at back of power steering pump and install spacer nuts (12) at "E & F". Remove bolt at location "G". Install bracket (10) using bolts (15) washers (16) in holes "E & F". Install bolts (18), washers (20) in holes "H and I". Install bolt (14) with washer (16) in hole "G". Tighten bolts at all locations.
5. Install pump plate (9) with bolts (18), lockwashers (20) and nuts (21) in top of plate, and bolts (18a), lockwashers (20) and flatwashers (19) in bottom slide of plate. Mount clutch pump (24) on plate (9) with pump bolts provided. Line up clutch pulley with drive pulley (1) and tighten pump bolts securely. Install IPKD-25 idler pulley (25) and small spacers (27) onto bracket (8) in 5/8" hole with bolt (31). **NOTE:** Add or subtract spacers (27) to line up idler pulley with drive pulley (1) and clutch pump pulley. Battery box may need to be notched or possibly rotated 90° for clutch pump clearance. Check cooler return lines so there is one inch minimum clearance to clutch.
6. Remove fan studs and replace with provided studs (5). Install fan spacer (4) and fan. **IMPORTANT:** Align marks on fan flange and water pump pulley marked in step 1.
7. Install serpentine drive belt and tensioner. Install clutch pump drive belt (23). Adjust clutch belt(s) to proper tension. Tighten bolts (18) on clutch pump plate.
8. Install fan shroud and connect battery(s).

CAUTION: Check all engine compartment hoses and electrical wiring that may have been disturbed or re-routed during kit installation to be sure that hoses are not kinked, that they do not touch any high temperature items, and that they do not interfere with any linkage components.

NOTE: This kit is designed to operate successfully with the standard fan supplied by the manufacturer of your truck. Due to O.E.M. assembly tolerances, visually make certain that there is adequate clearance between fan and drive pulley, and also fan to radiator. It may be necessary to use a longer spacer for pulley clearance. If there is little clearance to the radiator, check with Chevrolet dealership to insure that it will not flex into the radiator before operating. Move radiator if necessary. Fan shroud may need notched for belt clearance.

CMKC95-6500-A-AC
 CMKC95-6500-AH-AC
 1988-95 CHEVY
 C & K 1500,2500,3500
 6.2,6.5 Diesel W-WO/AC
 (SERPENTINE)

NOTE: Without brace on
 alternator-use spacer (11)
 at location "D".

Torque Specs (Dry)	
8mm	- 22 ft. lbs.
10mm	- 43 ft. lbs.
3/8 in.	- 45 ft. lbs.
5/8 in.	- 150 ft. lbs.

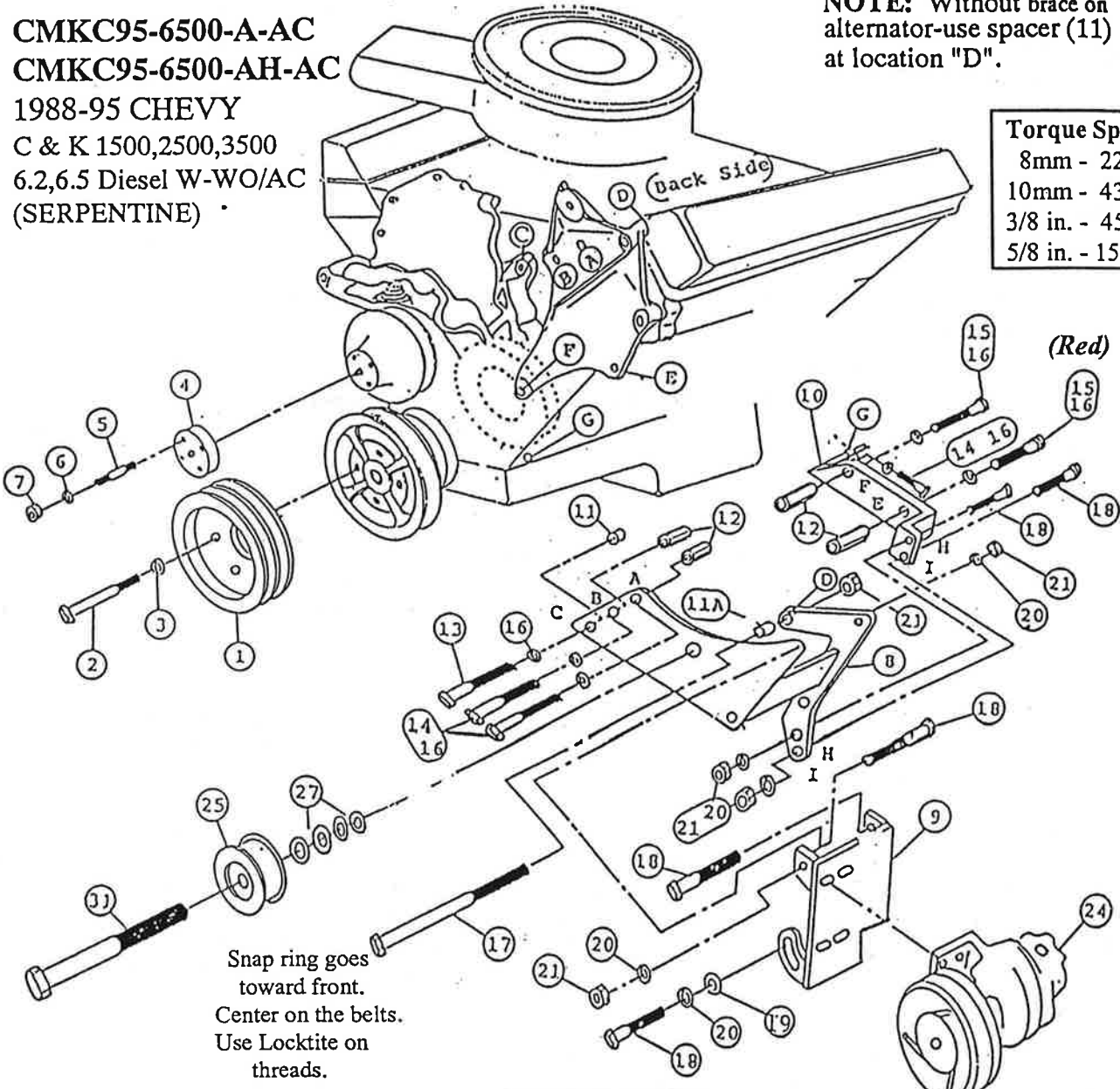

PARTS LIST

(Sold Separately)

- | | | |
|-------------------------|------------------------------|---|
| 1. CPC 632 (1) | 11a. SP88-0.250 (1) | 21. 3/8 NC (6) |
| 2. 10mm X 100mm 1.5 (4) | 12. SP1015-1.500 (4) | 23. AX-58 (2), H.D.: AX-60 (2)
(Not Shown) |
| 3. 10mm LW (4) | 13. 10mm X 120mm 1.5 (1) | 24. Clutch Pump Assembly
(Sold Separately) |
| 4. FSO 609 (1) | 14. 10mm X 30mm 1.5 (3) | IDLER ASSEMBLY (IPKD-25) |
| 5. 8mm X 55mm 1.25 (4) | 15. 10mm X 25mm 1.5(Red) (2) | 25. IPCD (1) |
| 6. 8mm LW (4) | 16. 10mm LW (6) | 27. IPW14 (6) |
| 7. 8mm 1.25 (4) | 17. 3/8 X 6 NC (1) | 31. 5/8 X 2 1/2 NC (1) |
| 8. CMB 650 (1) | 18. 3/8 X 1-1/2 NC (4) | |
| 9. CMP 651 (1) | 18a. 3/8 X 1 NC (1) | |
| 10. CMB 631 (1) | 19. 3/8 FW (2) | |
| 11. SP88-0.500 (1) | 20. 3/8 LW (8) | |

NOTE: May have to remove bolts (18 & 18a) so pump and plate may be removed to get belts on, leave pump secured to plate.

NOTE: If truck has short studs at locations "A & B" remove factory nuts from studs and use 3/8 spacers and 10mm X 35mm bolts (bagged separately).