



**Muncie®
Power
Products**

**CMKC96-5057-A-AC
CMKC96-5057-AH-AC**

**1996-2000 CHEVY
C&K 1500,2500,3500
305,350 W-WO/AC
W-WO Dual Battery
(Serpentine)**

INSTALLATION NOTES

1. Disconnect battery terminal. Remove air filter assembly and top half of fan shroud. Remove serpentine belt, fan and pulley on crankshaft. Use wrench (21) provided to hold water pump pulley. Threads are right hand.
2. **IMPORTANT:** Due to variations in O.E.M. pulley make sure both pulleys fully seat together. Install serpentine and pump drive (1) pulleys on crankshaft; with bolts and lockwashers provided. Secure pulleys.
CAUTION: Be sure bolts provided have same threads as original bolts removed.
3. Remove alternator from O.E.M. mounting bracket. Leave wires attached secure alternator out of way. Remove O.E.M. alternator bracket. Remove two spring steel bushings from alternator bracket to re-use on pump bracket (7).
4. Install pump mounting bracket (7) with bolts (9 and 9a) provided. Use Loctite with no flatwasher on (bolt 9a) through the counter sunk hole at location "A". Use lockwashers at locations "B & C". Secure bracket.
5. Install two bushings, alternator and rear brace to bracket (7). Install both belt idlers from O.E.M. bracket to bracket (7) torque bolts to 37ft/lbs. Install serpentine belt.
6. Install clutch pump (23) to pump plate (8) with bolts provided. Make sure clutch pulley is in line with drive pulley (1). Tighten pump bolts securely. Install pump drive belts (22) and check clearance with belt tensioner. Fan shroud may need notched.
7. Adjust pump plate (8) for proper belt tension. Tighten bolts (10 & 11). Use nylon ties (20) to secure heater hoses out of way of pump. Use Adel clamp to secure AC line to fan shroud.
8. Install fan spacer (6) secure, install fan and secure. **NOTE:** A *mild* grade of Loctite type sealant on threads may be advisable. Install fan shroud, air filter, connect battery.
9. **CAUTION:** Check all engine compartment hoses that may have been disturbed or re-routed during kit installation to be sure hoses are not kinked, that they do not touch any high temperature item, and that they do not touch any moving components.

NOTE: This kit is designed to operate successfully with the standard fan supplied by the manufacturer of your truck. Due to O.E.M. assembly tolerances and change, visually make certain that there is adequate clearance between fan and drive pulley and fan to radiator. It may be necessary to use a different fan spacer for clearance.

CMKC96-5057-A-AC
CMKC96-5057-AH-AC

1996-2000 CHEVY 305,350 W-WO/AC

W-WO Dual Battery

(SERPENTINE)

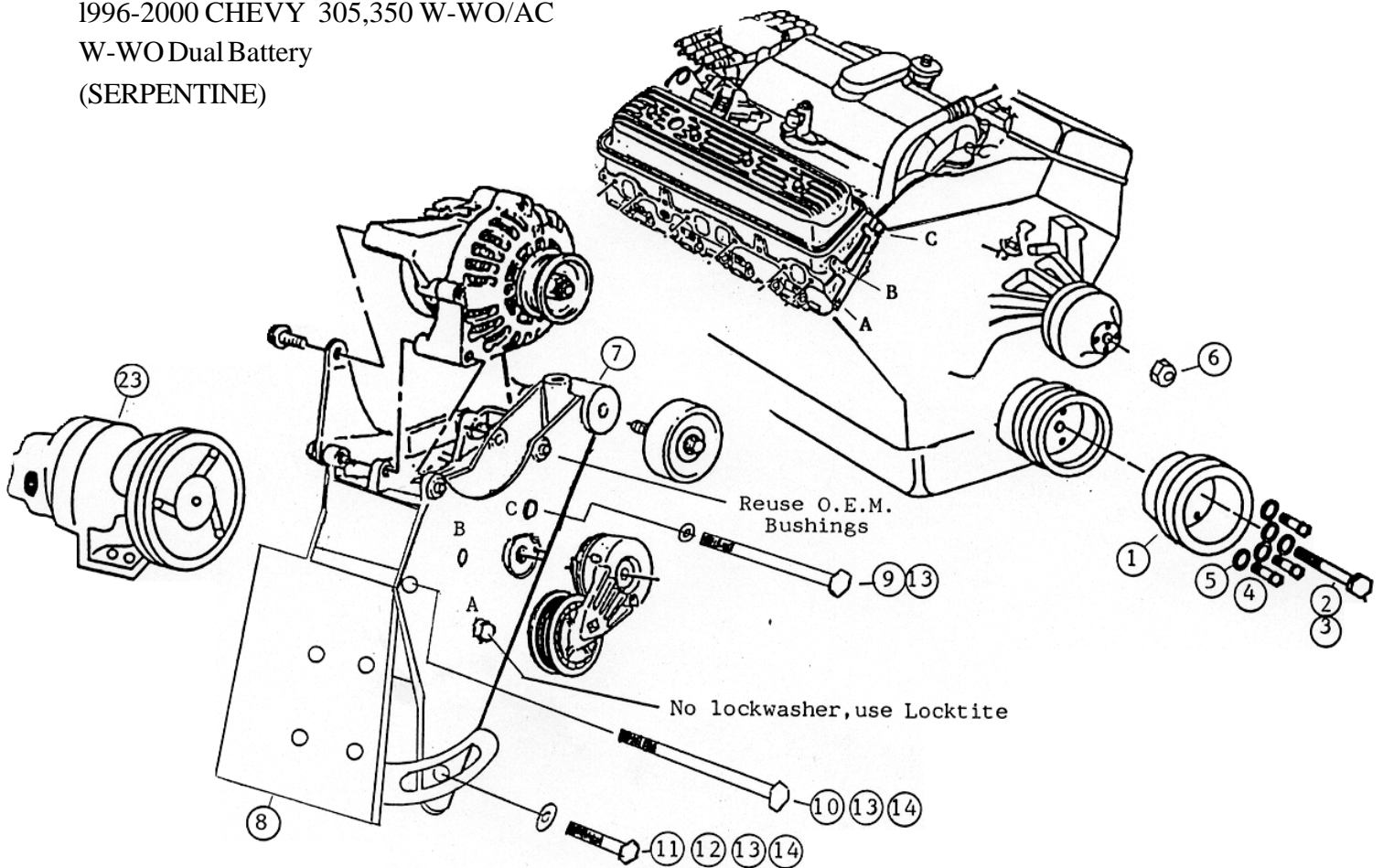

PARTS LIST

- | | |
|------------------------------|------------------------------|
| 1. CPC 352 (1) | 12. 3/8 FW (1) |
| 2. 7/16 X 3-1/2 NF GR.8 (1) | 13. 3/8 LW (4) |
| 3. 7/16 LW (1) | 14. 3/8 NC (2) |
| 4. 3/8 X 2 NF GR. 8 (3) | 15. 1/4 X 3/4 NC (1) |
| 5. 3/8 LW (3) | 16. 1/4 FW (1) |
| 6. FSK37R (1) | 17. 1/4 LW (1) |
| 7. CMB 370 (1) | 18. 1/4 NC (1) |
| 8. CMP 371 (1) | 19. 7/8 Adel Clamp (1) |
| 9. 3/8 X 6 NC Gr. 8 (2) | 20. 8" Nylon Tie (2) |
| 9a. 3/8 X 5-3/4 NC GR. 8 (1) | 21. WP Pulley Wrench (1) |
| 10. 3/8 X 5 1/2 NC (1) | 22. AX-50 (2) H.D.: AX-52 |
| 11. 3/8 X 1 1/4 NC (1) | 23. Clutch Pump Assembly (1) |
| | (Sold Separately) |