



**Muncie®
Power
Products**

CMKC96-6500-A-AC
CMKC96-6500-AH-AC
1996-00 Chevy C & K 2500,3500,HD
2001 3500 HD Only
6.5 Diesel
W-WO/AC,WO/Dual Alternator
(Serpentine)

INSTALLATION NOTES

1. Disconnect battery cable at battery(s). **IMPORTANT:** Mark fan flange and water pump pulley for proper re-installation. Remove upper half of fan shroud, fan, serpentine belt, and upper radiator hose support at location "E & F".
2. Install drive pulley (1) with provided bolts (2) and washers (3) **CAUTION:** Make certain the bolts (1) are the same thread as the O.E.M. bolt holes, usually 10mm 1.5 thread.
3. Remove bolt at location "A" on PS bracket. Install bracket (8) with bolts (13 & 15), lockwasher (16) and spacer (11) at location "A". Install upper radiator hose support over bracket (8) at locations "E & F". Use bolt (14) at location "G" and bolts (19) at locations "H & I" to install bracket (9) **NOTE:** Tighten bolts at all locations.
4. Install pump plate (10) with bolts (17 & 18), in top of plate, and bolt (18), in bottom slide of plate. Mount clutch pump (24) on plate (10) with pump bolts provided. Line up clutch pulley with drive pulley (1) and tighten pump bolts securely **NOTE:** Power steering line may require adjustment for pump clearance.
5. Remove fan studs and replace with provided studs (5). Install fan spacer (4) and fan. **NOTE:** Do not use fan spacer on 1999 and later model trucks with threaded fan clutch. Always check fan clearances before starting the vehicle. **IMPORTANT:** Align marks on fan flange and water pump pulley marked in step 1.
6. Install serpentine drive belt and tension belt. Install clutch pump drive belts (23) and adjust belts to proper tension using jackscrew (12). Tighten bolts (17 & 18) on clutch pump plate.
7. Install fan shroud and connect battery(s).

CAUTION: Check all engine compartment hoses and electrical wiring that may have been disturbed or re-routed during kit installation to be sure that hoses are not kinked, that they do not touch any high temperature items, and that they do not interfere with any linkage components.

NOTE: This kit is designed to operate successfully with the standard fan supplied by the manufacturer of your truck. Due to O.E.M. assembly tolerances, visually make certain that there is adequate clearance between fan and drive pulley and also fan to radiator. It may be necessary to use a longer spacer for pulley clearance. If there is little clearance to the radiator, a shorter fan spacer may be required or move radiator if necessary. Fan shroud may need notched for belt clearance.

NOTE: Access to power steering pump cap is limited, suggest checking when engine is cold.

CMKC96-6500-A-AC

CMKC96-6500-AH-AC

1996-00 Chevy C & K 2500, 3500, HD

2001 3500 HD Only

6.5 Diesel W-WO/AC, WO/Dual Alt.

(Serpentine)

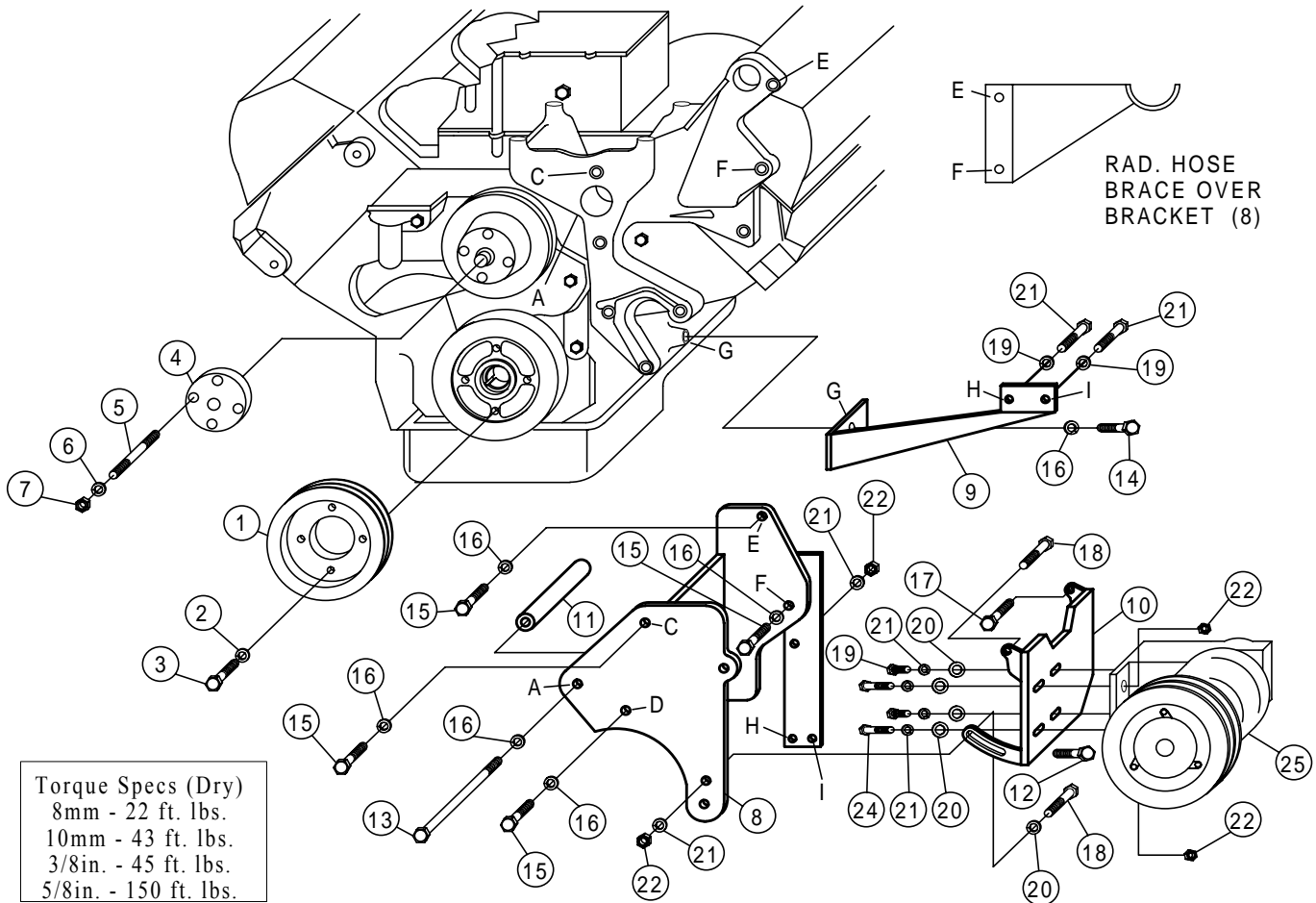

PARTS LIST

- | | |
|---|---|
| 1. CPC 632 (1) | 14. 10mm x 40mm 1.5 (1) |
| 2. 10mm x 100mm 1.5 (4) | 15. 10mm x 30mm 1.5 (4) |
| 3. 10mm LW (4) | 16. 10mm LW (6) |
| 4. FSO 602 (1) <i>(Not to be used on '99 & newer model trucks w/ threaded fan clutch)</i> | 17. 3/8 x 1-3/4 NC (1) |
| 5. 8mm x 45mm st (4) | 18. 3/8 x 1-1/4 NC (2) |
| 6. 8mm LW (4) | 19. 3/8 x 1 NC (4) |
| 7. 8mm 1.25 (4) | 20. 3/8 FW (5) |
| 8. CMB 661 (1) | 21. 3/8 LW (9) |
| 9. CMB 662 (1) | 22. 3/8 NC Nut (5) |
| 10. CMP 661 (1) | 23. Belts (Not Shown) (2)
Dayco AX-57
H.D.: AX-59 |
| 11. SP88-3.750 (1) | 24. 3/8 x 1-1/2 NC (2) |
| 12. 3/8 x 3-1/2 Jackscrew | 25. Clutch Pump Assembly
(Sold Separately) |
| 13. 10mm x 150mm 1.5, 10.9 (1) | |