



Muncie®
Power
Products

CMKC99-5360-YP6-AC

1999-Current Chevy Silverado

4.8,5.3,6.0

W-WO/AC

INSTALLATION NOTES

1. Disconnect negative battery cable. Remove the air cleaner duct, and the O.E.M. belt. Removing the fan shroud and fan makes installation easier, but is not necessary. (*Fan nut has right hand threads*). Remove the steel bracket holding the red junction box from the alt./powersteering bracket, and then remove the bracket from the box.
2. Using a hacksaw or other suitable tool, cut the ground ear from the aluminum bracket. Using a sander/grinder, dress the aluminum bracket so the pump bracket will fit without interference as shown on the attached illustration.
3. Remove bolts at locations “A, B & C”. Install the pump bracket (1) with bolts and lockwashers (5) & (6). Make certain there is no interference with the aluminum alternator bracket, then install bolts loosely. Install brace (2) to the back of bracket (1) with bolts and lockwashers (8) & (6) and to the cylinder head at location “D” with bolt and lockwasher (7) & (6). After all bolts are installed, tighten bolts at locations “A”, “B” & “C” first, then the bolts on the brace.
4. Install the pump (9) onto the bracket with bolts, flatwashers, lockwashers & nuts (19,13,14& 15), tighten securely. Install coil adapter plate (10) onto the front of the pump bracket using the four 1/4 tapered bolts (20). Make certain the cutout is towards the top. Install the coil and clutch as per manufacturers instructions. On 2002 and up model year trucks only: if the vehicle is equipped with a 105amp alternator, install the idler (3) into the lower hole. If the vehicle has 130 amp alternator, install the idler into the top hole.
5. Install the new belt according to the illustration. Install the fan and fan shroud if they were removed. Install the air cleaner duct and connect the battery cable. Run engine and check for proper belt tracking and clearances.

NOTE: Check all engine compartment vacuum hoses and electrical wiring that may have been disturbed or re-routed during kit installation to be sure that hoses are not kinked, that they do not touch any high temperature item, and that they do not interfere with any linkage components.

NOTE: Recommended no larger than 1.25 CID pump or 10 HP.

CMKC99-5360-YP6-AC
1999-Current Chevy Silverado
4.8,5.3,6.0
W-WO/AC

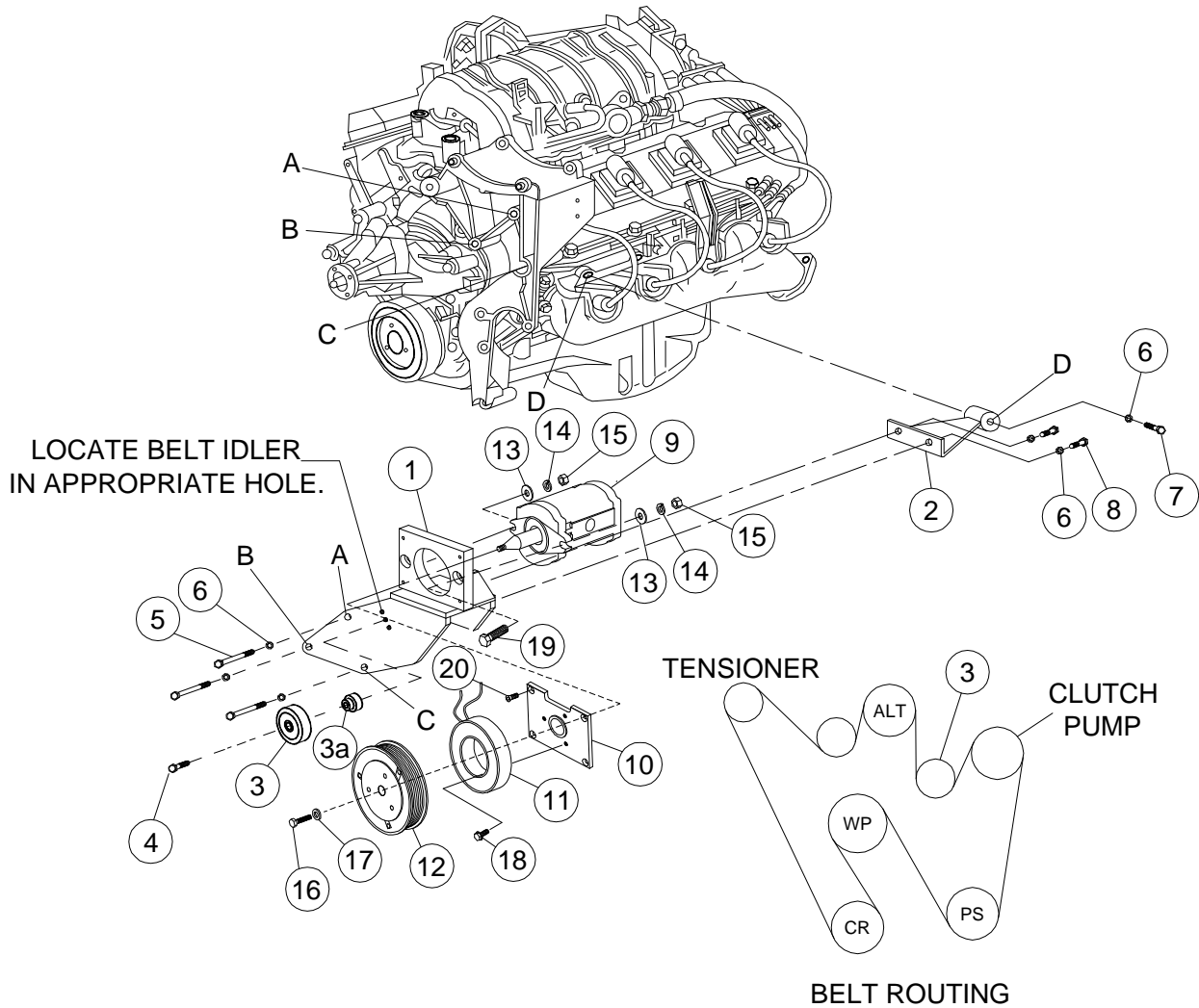

PARTS LIST

- | | |
|--|--|
| 1. CMP 38A (1) | 11. Coil (Sold Separately) |
| 2. CMB 381 (1) | 12. Clutch (Sold Separately) |
| 3. 89007 Dayco (1) | 13. 3/8 FW (2) |
| 3a. CMB 3867 (1) | 14. 3/8 LW (2) |
| 4. 10mm x 40mm 1.5 (1) | 15. 3/8 NC Nut (2) |
| 5. 10mm x 140mm 1.5 (3) | 16. Capscrew-19T38756 (1) (T=20 ft/lbs)(comes w/Clutch) |
| 6. 10mm LW (6) | 17. Flat Washer- 21MZ3487 (1)(comes w/Clutch) |
| 7. 10mm x 60mm 1.5 (1) | 18. Capscrew- 19T34530 (3) (T=8-10 ft/lbs)(comes w/Coil) |
| 8. 10mm x 25mm 1.5 (2) | 19. 3/8 x 1-1/2 (2) |
| 9. Clutch Pump Assembly (1)
(Sold Separately) | 20. 1/4 x 3/4 NC FHSCS (4) |
| 10. MCA01 plate (1) | 21. Belt 5061150 (1) |



**Muncie[®]
Power
Products**

BULLETIN

CMKC99-5360-YP6-AC 1999-Current Chevy Silverado 4.8,5.3,6.0 W-WO/AC

All 4.8, 5.3, and 6.0 litre engines will require the removal of aluminum from the O.E.M. alternator bracket in order for the pump bracket to fit properly. The illustration shows the area that needs to be removed.

