



INSTALLATION NOTES

1. Drain radiator below upper radiator hose. Remove hose. Remove fan and fan shroud. Remove driver side upper shroud support. Remove belt. Remove return hose from power steering reservoir and let reservoir drain. Remove bolts from power steering pump through the holes in the pulley. Leaving pressure lines attached, set pump aside on passenger side of engine. Remove power steering pump brackets.
2. *(If installing on a truck with a manual transmission skip to step 3.)* Remove Automatic transmission cooler lines from radiator side by removing quick clips. Drain fluid out of lines. Mark cooler lines in approximate location that they should be cut looking at the illustration. Check location by routing replacement hoses and adjust cut location if necessary. Cut with a tubing cutter and discard radiator side of the O.E.M. line. Install new hoses(25) as shown in illustration. **Note: Make sure to get compression fittings tight. Pressures in these lines may reach up to 300psi.** Fill transmission to suggested level with ATF Plus 4 transmission fluid.
3. Install studs (2) in timing cover w/nuts (5). Install pump onto bracket using pump hardware included in the kit Install coil adapter (3) using bolts (21). Install coil and clutch per manufacturer instructions. Install 5/8 hose(13) onto return hose using hose barb (15) and hose clamps(14). Power steering lines on steering gearbox may need moved for proper clearance to the pump.
4. Install pump and bracket assembly onto studs (2) using nuts(5). NOTE: It may be easier to install hoses and power wire before power steering pump is reinstalled. Install power steering pump onto bracket using bolts (6) and LW's (4). Install new belt (20) according to the belt diagram. Install idler (10) in lowest hole location possible while tensioner is retracted fully using bolt (12), FW (11), and bushing (9).
5. Install hose rest (7) to head on driver side using flange head bolts (8). Reinstall fan and fan shroud. Cut 3/4" off radiator side of top radiator hose and reinstall. Connect new power steering return hose (13) to power steering reservoir using O.E.M. hose clamp. Fill reservoir w/ATF Plus 4 transmission fluid. Fill radiator and overflow tank. Check for proper belt tracking and clearances.

CMKD11-6700-YP8-AC

2011-Current Dodge D-2500-5500

6.7 Cummins Diesel

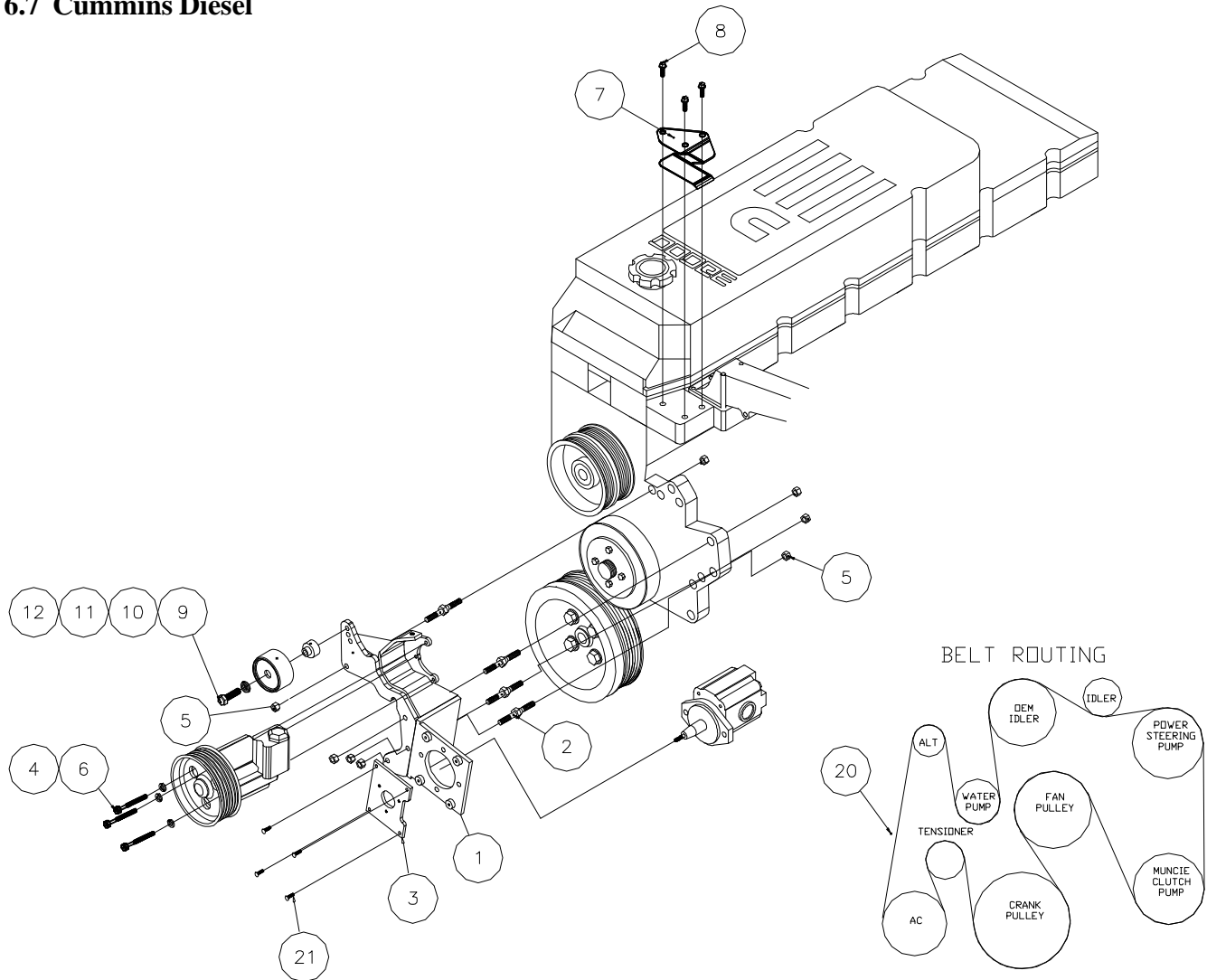

PARTS LIST

1. DMP58A-I8 (1)
2. 8mm Stud 080751.25 ST (4)
3. MCA01 (1)
4. 8mm LW (3)
5. 8mm Flange Nut (8)
6. 8mm x 80mm (3)
7. DMB563 (1)
8. 10mm x 20mm Flange (3)
9. DMB562 (1)
10. 89016 Dayco (1)
11. 3/8 FW (1)
12. 10mm x 45mm (1)

ITEMS 13-19 NOT SHOWN

13. 14" of 5/8" Oil Hose (1)
14. #10 Hose Clamp Dayco (2)
15. 5/8" Double Ended Hose Barb (1)
16. 3/8 LW (2)
17. 15" Plastic Tie Strap (1)
18. 3/8" x 1 1/2" (2)
19. 3/8" Nut (2)
20. 5081325 Dayco (1)
21. 1/4" x 3/4" FHSCS (4)

ITEM 22 TRANSMISSION LINE KIT

22. D58TCHK (1) (INCLUDES 2 HOSES)

Transmission cooler line modifications



Install quick clip end of hoses to radiator side.



Cut transmission cooler lines and install hoses using the compression fittings making sure to get them tight enough without collapsing tube to prevent leaking.