



**Muncie®
Power
Products**

CMKD19-67LD-YP8-AC

2019-2024 RAM 2500-5500

6.7L I6 Cummins Diesel w/ AC, w/o OEM Dual Alternators

Requires SAE Two-Bolt 'A' Flange Pump, 8-Groove Clutch
Recommended 1.75 in.³ or 8 gal. Pump w/ 12hp Restriction
Using a Rear Ported Pump Would Be Best

NOTE: Will NOT Work w/ 6" O.D. Clutch
NOTE: For Use w/ Trucks Equipped w/ Lane Departure

INSTALLATION NOTES

1. The buyer is responsible for providing trained and experienced installation decision making with technical know-how to apply professional judgment that specifically applies to each individual installation.
2. Be sure to read and understand all available information including but not limited to instructions, warnings, sale terms, and warranties for the vehicle and all system components prior to attempting installation.
3. Disconnect the negative battery cables.
4. Remove the top half of the fan shroud. Remove the four nuts holding the fan ring to the engine. Unplug the fan wire. Using the appropriate tool loosen the fan nut (fan nut has right-hand threads). Then, remove the fan and fan ring from the engine compartment.
5. Remove the OEM engine belt.
6. On truck equipped with the Lane Departure option, this procedure will need to be performed prior to installing the pump bracket:
 - a. Drain the power steering fluid and remove the fill hose at the power steering pump.
 - b. Remove the bolt holding the fill hose fitting to the pump and remove the fitting.
 - c. Remove the O-ring from the OEM fitting, and install it onto the new fitting (29). Using caution not to damage the O-ring. Install the new fitting (29) into the power steering pump reusing the OEM bolt.
 - d. Install the hose onto the new power steering fitting (29). NOTE: Rotate the hose for best clearances of any hot or moving parts, and so it does not kink the hose.
 - e. Fill the power steering reservoir with approved fluid and check for leaks. After the engine has been running check fluid level and top off if necessary.
7. Remove and let hang the power steering pump for enough clearance to install the pump bracket in the next step. Then, remove the upper driver side fan ring brace from the engine. The brace will not be reused.
8. Install the pump assemblies according to the manufacturer's specifications onto the main bracket (1) with clutch pump mounting hardware (15-18). Do not install the clutch at this time. Install the main bracket (1) and clutch pump assembly onto the engine with mounting hardware (2-4). Do not tighten completely. Install the main bracket support brace (5) onto the main bracket (1) and the engine with mounting hardware (6-7) and bolt (9). Tighten all bolts very lightly. Then, tighten bracket bolts and brace bolts securely. Install clutch assembly (19-23) according to the manufacturer's specifications with coil adaptor assembly (24-25).
9. Reinstall power steering pump with OEM hardware. Install the smooth idler pulley assembly (11-14) onto the main bracket (1) in the lowest hole possible for now. Install belt (28) according to belt diagram. If the belt is too short. Move the smooth idler pulley assembly (11-14) up a hole until the belt can be installed.
10. Replace the fan and fan shroud with OEM hardware. Install the fan shroud support brace (8) onto the main bracket (1) with bolt (9) and to the fan ring using bolt (10) and the OEM nut. Replace the top half of the fan shroud with OEM hardware



**Muncie®
Power
Products**

CMKD19-67LD-YP8-AC

2019-2024 RAM 2500-5500

6.7L I6 Cummins Diesel w/ AC, w/o OEM Dual Alternators

Requires SAE Two-Bolt 'A' Flange Pump, 8-Groove Clutch
Recommended 1.75 in.³ or 8 gal. Pump w/ 12hp Restriction
Using a Rear Ported Pump Would Be Best

NOTE: Will NOT Work w/ 6" O.D. Clutch

NOTE: For Use w/ Trucks Equipped w/ Lane Departure

INSTALLATION NOTES (CONTINUED)

11. If there is not adequate clearance between the pump bracket and power steering hose. Install clearance bracket (26) with bolt (27) as shown in the photo.
12. Reconnect the battery cables.

CAUTION: Before starting the engine. Check to make certain no wires, hoses, etc. that may have been disturbed during installation do not come in contact with any hot or moving parts. Run the engine and check for proper belt tracking, adjust if necessary. It is the installer's responsibility to make sure that all components are in proper position and alignment.



Muncie® Power Products

CMKD19-67LD-YP8-AC

2019-2024 RAM 2500-5500
6.7L I6 Cummins Diesel w/ AC, w/o OEM Dual Alternators

Requires SAE Two-Bolt 'A' Flange Pump, 8-Groove Clutch
Recommended 1.75 in.³ or 8 gal. Pump w/ 12hp Restriction
Using a Rear Ported Pump Would Be Best

NOTE: Will NOT Work w/ 6" O.D. Clutch

NOTE: For Use w/ Trucks Equipped w/ Lane Departure

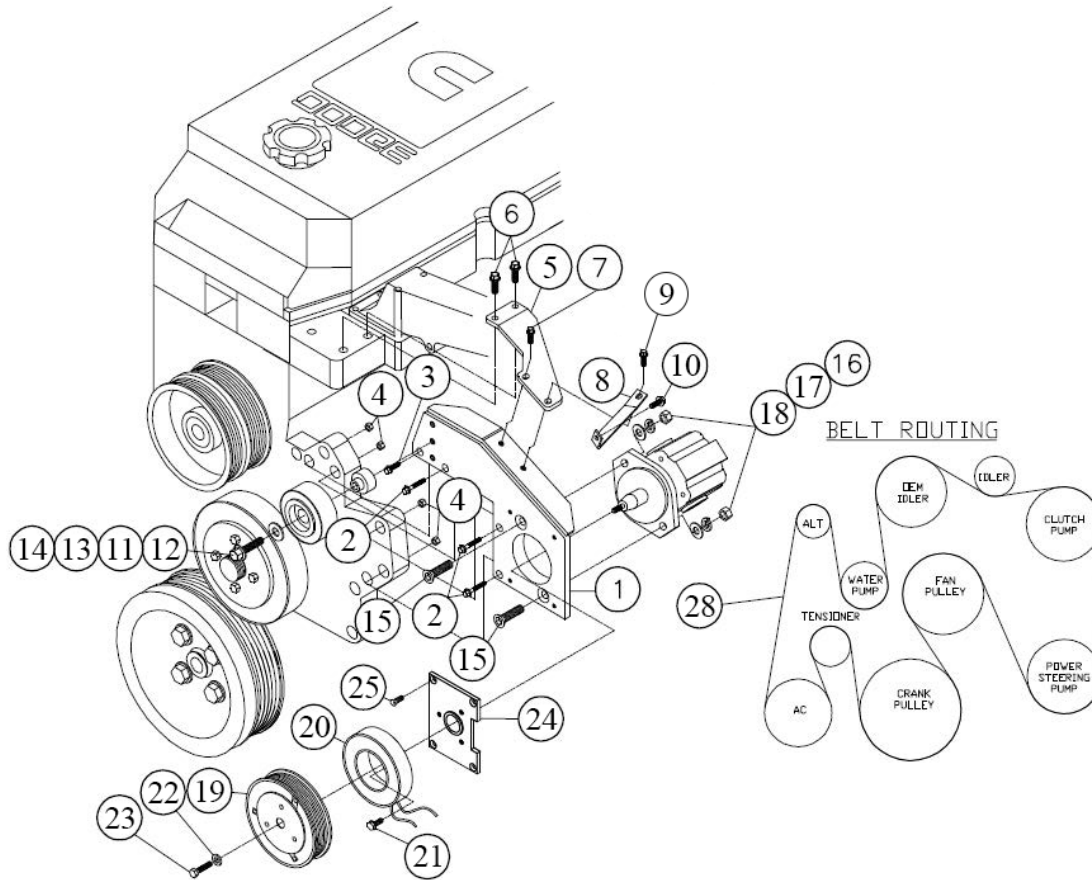

PARTS LIST							
Item	Part Number	Description	Qty.	Item	Part Number	Description	Qty.
Main Bracket				Clutch Pump Mounting Hardware			
1	RMP60A	Main Bracket	1	15	1003930	3/8"-16 x 1-3/4" NC Gr5 FHSCS	2
Main Bracket Mounting Hardware				Clutch Assembly (Not Included with Mounting Kit)			
2	1013316	M8-1.25 x 50mm 10.9Gr Hex Flg. Bolt	3	16	1010314	3/8"-16 NC Gr5 Hex Nut	2
3	1011887	M8-1.25 x 25mm 10.9Gr Hex Flg. Bolt	1	17	1010315	3/8" USS Lock Washer	2
4	1013333	M8-1.25 10.9Gr Hex Flg. Nut	4	18	1011654	5/16" USS Flat Washer	2
Main Bracket Support Brace				Coil Adaptor Assembly			
5	DMB591	Main Bracket Support Brace	1	19	N/A	Clutch Assembly	1
Main Bracket Support Brace Mounting Hardware				20	N/A	Coil Assembly	1
6	1008390	M10-1.5 x 20mm 10.9Gr Hex Flg. Bolt	2	21	19T34530	Cap screw (T=8-10 ft/lbs) (Comes w/ Clutch Assembly)	3
7	1013329	M8-1.25 x 20mm 10.9Gr Hex Flg. Bolt	1	22	21MZ3487	Flat Washer (Comes w/ Clutch Assembly)	1
Fan Shroud Support Brace				Power Steering Hose Adapter Bracket			
8	DMB592	Fan Shroud Support Brace	1	23	19T38756	Cap screw (T=20 ft/lbs) (Comes w/ Clutch Assembly)	1
Fan Shroud Support Brace Mounting Hardware				Coil Adaptor Assembly			
9	1013329	M8-1.25 x 20mm 10.9Gr Hex Flg. Bolt	1	24	MCA01	Coil Adaptor Plate	1
10	1011887	M8-1.25 x 25mm 10.9Gr Hex Flg. Bolt	1	25	1007577	1/4"-20 x 3/4" NC Gr5 FHSCS	4
Idler Assembly				Belt			
11	89048	Dayco Smooth Idler Pulley	1	26	RMB601	Power Steering Hose Clearance Bracket	1
12	DMB594	Machined Idler Bushings	1	27	1016342	M6-1.0 x 30mm 10.9Gr Hex Flg. Bolt	1
13	1007644	3/8" Flat Washer	1	Power Steering Fitting (For Lane Departure Trucks)			
14	1006630	M10-1.5 x 45mm 10.9Gr Hex Bolt	1	28	5081305	Dayco 8-Groove, 130.5" Belt	1
				29	RMB603LD	Power Steering Fitting	1



Muncie® Power Products

CMKD19-67LD-YP8-AC

2019-2024 RAM 2500-5500
6.7L I6 Cummins Diesel w/ AC, w/o OEM Dual Alternators

Requires SAE Two-Bolt 'A' Flange Pump, 8-Groove Clutch
Recommended 1.75 in.³ or 8 gal. Pump w/ 12hp Restriction
Using a Rear Ported Pump Would Be Best

NOTE: Will NOT Work w/ 6" O.D. Clutch
NOTE: For Use w/ Trucks Equipped w/ Lane Departure



Power Steering Hose Clearance Hardware (26-27)



Power Steering Fitting (29) (For Lane Departure Trucks)

CW Mill Equipment Co., Inc. Mounting Kit and Mounting Kit Component Disclaimer: (1.) Due to the custom nature and variation of all add-on systems of this type, no complete system kits are offered by the manufacturer, and any group of parts marketed as a kit is limited to only the individually defined parts in that specific kit. The system designer's rotating accessory components are not included, offered, or fully known by the manufacturer. In addition to the absence of the rotating accessory system, other potential components such as additional clamps, brackets, wear liners, hardware, or other items that may be required by the system designer must be identified and supplied by the actual system designer. (2.) Due to vehicle manufacturer's assembly tolerances, production changes, and installation variances, it is the buyer's responsibility to ensure adequate clearance for all components including space for and safe location of the fan, radiator, all lines, and wires. Check for possible movement, vibration, friction points, heat exposure and/or shifting of any and all components such as hoses, wires, and all other components including those that may otherwise be considered non-moving and/or unaffected by the installation (3.) The buyer is responsible for the entire installation of a mounting kit as the mounting kit is part of a custom process controlled by the buyer through their whole system design and directed installer as the installer evaluates, locates, routes, aligns, and tightens all components while determining if additional clamps, brackets, wear-liners, or other components may be required, beyond those included in the kit. Any additional items required, beyond those included in the kit, are to be provided at the expense of the buyer. (4.) The buyer is responsible for the development and communication of their whole system installation procedures, safety precautions, application, and use of the engine accessory mounting kit in their system, including efforts to maintain vehicle control and prevent pinch, wear, impact, and/or burn exposure on all hoses, wires, and other parts. (5.) The buyer is responsible for providing trained and experienced installation decision making with technical know-how to apply professional judgment that specifically applies to each individual installation. The buyers chosen installers must be qualified and experienced technicians that are familiar with the vehicle and accessory being mounted as well as the buyer's whole system design and installation procedures associated with the kit. (6.) The buyer is responsible for determining and achieving compliance to all regulatory issues that apply to the use of all products. (7.) The manufacturer reserves the right to make changes and/or improvements to any product at any time with or without notice.