



**Muncie<sup>®</sup>  
Power  
Products**

**CMKD91-5900-A-AC**

**1991-93 DODGE TRUCK, D-250,350**

**5.9 Cummins Diesel W-WO/AC**

**W/Intercooler**

**(Serpentine)**

## **INSTALLATION NOTES**

---

1. Disconnect battery, loosen battery in tray. Remove fan with 1 1/2" wrench, threads are left-handed, tap wrench toward driver's side fender. Remove fan and shroud, shroud held in with clips. Remove fan from clutch, save bolts.
2. Remove oil fill tube from front of engine, cover unscrews. Install oil seal from fill tube onto hole cover (9), install hand tight only. Replace front valve cover with cover (6) and cap (7 & 8), re-use gasket. **NOTE:** Oil must be added 1 quart at a time; use of a pressurized oil filler pump will cause oil to spew out valve cover.
3. Loosen serpentine belt from alternator pulley, insert 3/8 inch drive ratchet or breaker bar into square hole on idler assembly. Leave belt wrapped on engine pulleys.
4. Remove pulley from fan idler assembly. Replace with drive pulley (1), secure bolts (2). Tension serpentine belt, make sure belt is properly seated on all pulleys, misalignment will quickly damage belt on start-up. Install fan adapter (4) until snug on pulley (1). Tighten until adapter bolt holes align with pulley tapped holes, install socket head bolts (5). Install fan and shroud, secure shroud. Bolt fan to adapter using original bolts.
5. Install bracket (10) with bolts (12 & 14) provided, secure all bolts. Loosely bolt clutch pump to pump plate (11) with pump bolts provided. Align clutch pulley to drive pulley (1), tighten pump bolts securely. **IMPORTANT:** Make sure throttle linkage will not make contact with bracket (10), trim bracket if necessary to provide clearance. **NOTE:** Corner of fan shroud may need to be notched for clutch clearance.
6. Install pump drive belts (21), adjust pump plate (11) for proper belt tension. Tighten bolts (16 & 17) on pump plate.
7. Secure battery in tray as far from clutch as possible. **IMPORTANT:** Make sure clutch cannot contact battery during operation. Relocate battery closer to fender if necessary. Connect battery.

**NOTE:** Make sure pump drive belts have adequate clearance to fan and fan has clearance to radiator.

**NOTE:** Make sure electric sender on fuel pump has clearance to bracket (10) and wires are protected to prevent damage.

# CMKD91-5900-A-AC

1991-93 DODGE

5.9 Cummins Diesel

W-WO/AC, W/Intercooler (Serpentine)

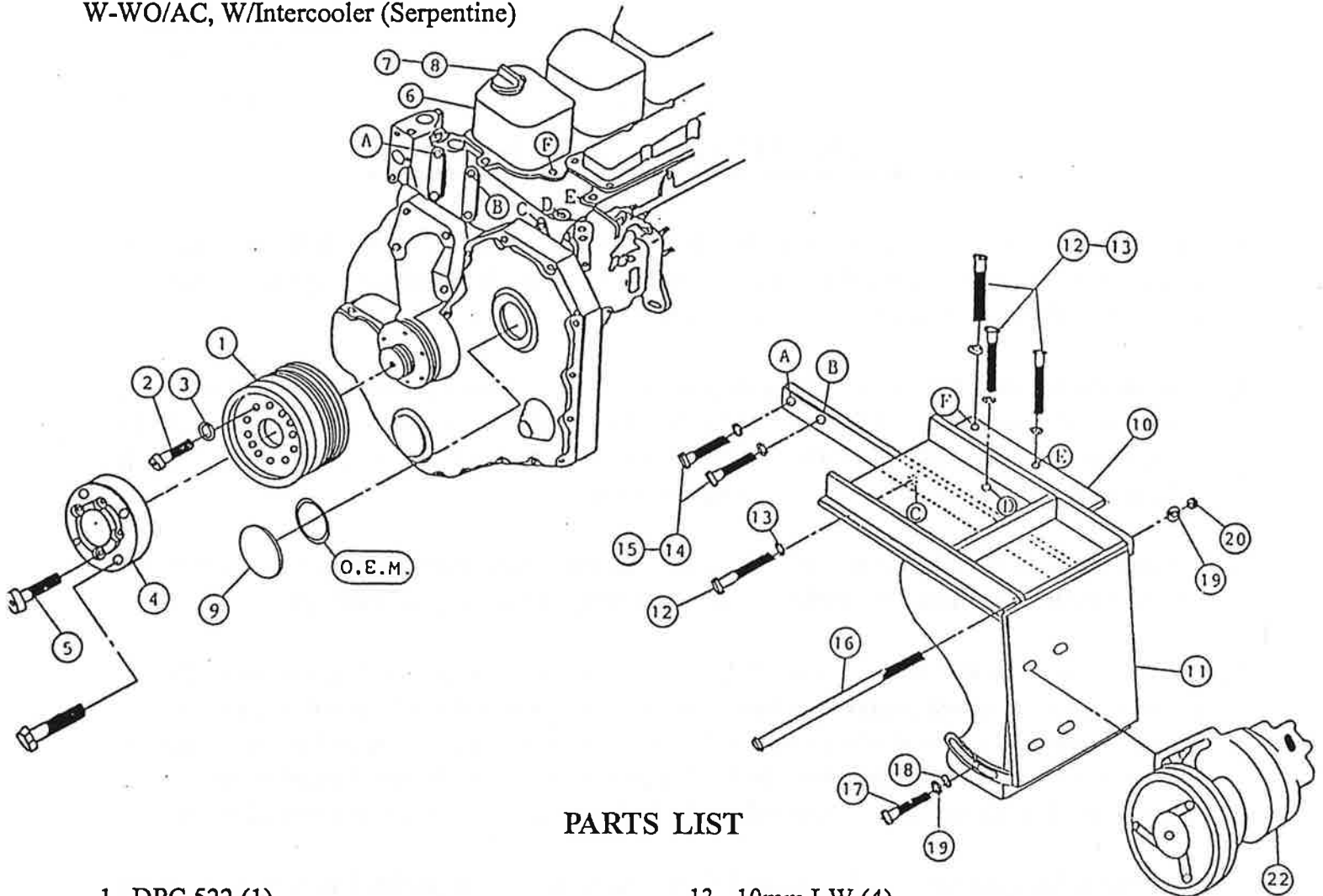

## PARTS LIST

- |                            |                              |
|----------------------------|------------------------------|
| 1. DPC 522 (1)             | 13. 10mm LW (4)              |
| 2. 6mm X 16mm 1.0 SHCS (6) | 14. 8mm X 25mm 1.25 (2)      |
| 3. 6mm LW (6)              | 15. 8mm LW (2)               |
| 4. DPA 522 (1)             | 16. 3/8 X 4 1/2 NC (1)       |
| 5. 3/8 X 3/4 SHCS (4)      | 17. 3/8 X 1 1/4 NC (1)       |
| 6. Valve Cover (1)         | 18. 3/8 FW (1)               |
| 7. Fill Cap (1)            | 19. 3/8 LW (2)               |
| 8. Cap Seal (1)            | 20. 3/8 NC (1)               |
| 9. Hole Cover (1)          | 21. AX-50 (2) (Not Shown)    |
| 10. DMB 520 (1)            | 22. Clutch Pump Assembly (1) |
| 11. DMP 521 (1)            | (Sold Separately)            |

**NOTE:** Move battery in tray toward fender for additional clearance to clutch pump.