



**Muncie[®]
Power
Products**

CMKE02-4900-P6-AC

**1999-2011 Mitsubishi
Engine Model 4M50 4.9 L**

INSTALLATION NOTES

1. Disconnect the negative battery cable. Drain the engine coolant until coolant level is below the thermostat housing. Undo top radiator hose, remove the four nuts holding the fan to the fan pulley. Remove the OEM studs from the fan pulley and replace them with studs (2). Remove heater hose (A).
2. Install pulley (1) and the fan with OEM nuts. Remove the bolt at location (C) if present. Install the pump bracket (3) with bolts (4) & lockwashers (5). Be sure to start all bolts before tightening any of the bolts. Install replacement heater hose (12) using OEM hose clamps. Install pump with bolts (8,9), nuts (11) & lockwashers (10). Install belt tensioner (6) onto pump bracket (3) using bolt (7). Install belt (13).
3. Replace engine coolant and reconnect battery cable. Run engine and check for proper belt tracking and clearance of all moving parts.

CMKE02-4900-P6-AC

1999-2011 Mitsubishi

Engine Model 4M50 4.9L

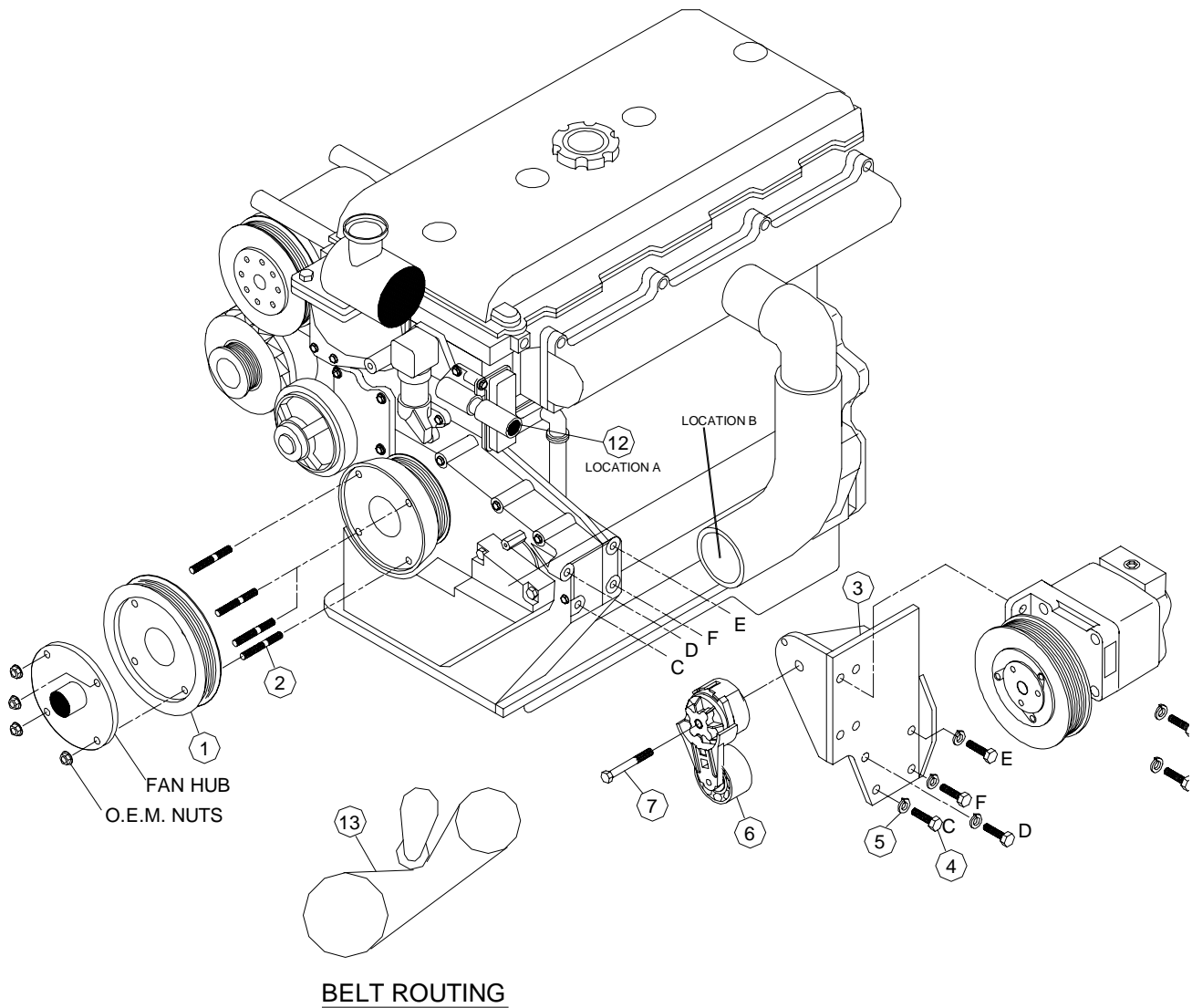

PARTS LIST

- | | |
|----------------------------|--|
| 1. MPC 426 | 8. 3/8 x 1 (2) |
| 2. 8mm x 45 studs (4) | 9. 3/8 x 1 1/2 (2) |
| 3. MMB 421-6 (1) | 10. 3/8 LW (4) |
| 4. 10mm x 30mm (4) | 11. 3/8 Nut (2) |
| 5. 10mm LW (4) | 12. 5/8 Formed Hose (1) |
| 6. 89200B Tensioner | 13. 5060515 (1) Belt |
| 7. 10mm x 80mm Flange Bolt | 14. Clutch Pump Assembly (Sold Separately) |