



Muncie®
Power
Products

CMKE17-3000-P8-AC
2017 MITSUBISHI FUSO
FE, FG, CANTER
3.0L DIESEL

INSTALLATION NOTES

1. Disconnect the negative battery cables. Remove the lifting lug from the front of the cylinder head. Remove the three bolts holding the fan shroud ring to the engine. Push the aluminum ring forward. Be careful not to damage the radiator. Remove the eight bolts holding the fan to the fan clutch.
2. Install the drive pulley(1) onto the engine crank pulley with bolts(2), torque to 12ft lb. Install idlers(10) using bolts(12,15), flat washers(11,14), and bushings(9,13). Install pump onto bracket(3) using bolts(19), and lock washers(20). Install bracket(3) using bolts(4,6,8) and lock washers(5,7). Loosen bolts(19) and align the clutch with the drive pulley using a quality straight edge. **NOTE: Belt alignment is the installer's responsibility.** Install tensioner(16) using bolt(17). Install the drive belt(21) as shown in the diagram on the back. Install the fan spacer(18) and fan using bolts(2). Reinstall the fan shroud ring reusing OEM hardware.
3. Reconnect the negative battery cable. Run engine and check for proper belt tracking and clearance of all moving parts.

CMKE17-3000-P8-AC

2017 MITSUBISHI FUSO

FE, FG, CANTER

3.0L DIESEL

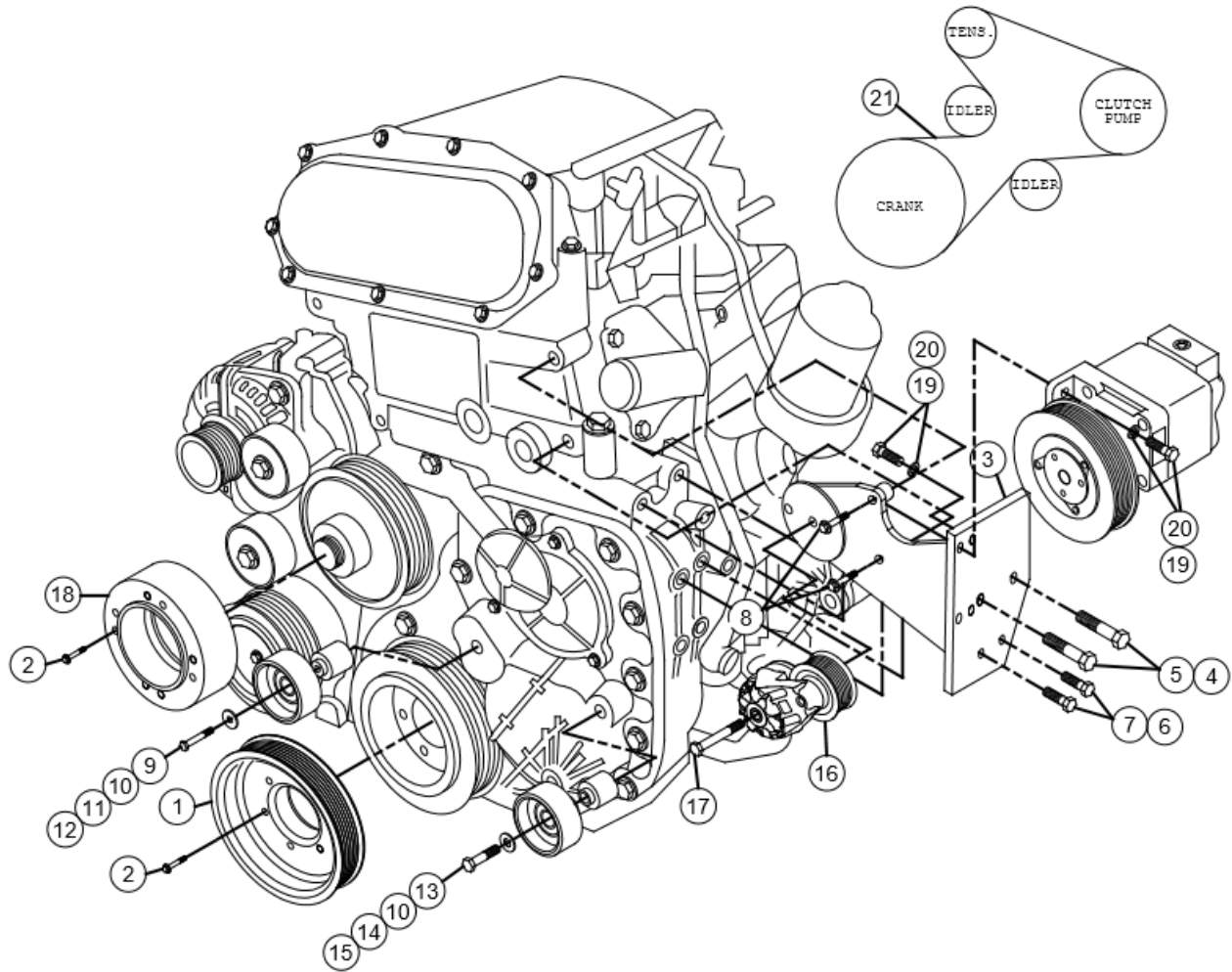

PARTS LIST

- | | |
|--------------------------|-----------------------|
| 1. MPC318 (1) | 11. FMB483-I6 |
| 2. 6mm x 60mm flg (14) | 12. 8mm x 50mm (1) |
| 3. MMP311-8 (1) | 13. MMB301 (1) |
| 4. 12mm x 65mm x1.25(2) | 14. 3/8 FW (1) |
| 5. 12mm LW (2) | 15. 10mm x 70mm (1) |
| 6. 10mm x 35mm x1.25 (2) | 16. 89200D-GPCD8 (1) |
| 7. 10mm LW (2) | 17. 10mm x 80mm (1) |
| 8. 8mm x 55mm Flg (2) | 18. FS031 (1) |
| 9. MMB302 (1) | 19. 3/8x1-16 (4) |
| 10. Dayco 89016 (2) | 20. 3/8 LW (5) |
| | 21. Dayco 5080630 (1) |