



**Muncie®
Power
Products**

CMKF00-730M-A-AC

2000-01 Ford Truck F-650,750

7.3 Diesel

W-WO/AC, WO Air brakes

INSTALLATION NOTES

1. Disconnect negative battery terminals. Remove fan and fan shroud. Use wrench (15) when removing fan (*left hand threads*). Install drive pulley (1) with bolts (2) and washers (3) provided.
2. Install bracket (5) at locations "A,B,C & D with bolts (7), (8) and washers (9). Secure bolts at all locations.
NOTE: Some metal may need to be removed off the bracket on the valve cover on the left hand side of the engine.
3. Install pump (16) to mounting plate (6) with pump bolts provided. Align clutch pulley with drive pulley (1). Tighten pump bolts. Install pump drive belts (17), and adjust pump plate (6) for proper belt tension. Tighten (10) and (11).
4. Install fan spacer nut (4), fan and shroud. Tighten fan and spacer nut to 90-110 ft.\lbs. (factory recommended spec.) (*left hand threads*).
NOTE: There are two fan spacer nuts included in this kit, use the correct one for your truck.
5. Check and tighten all bolts. Connect battery terminal. Re-tighten belts after break in period.

CAUTION: Check all engine compartment vacuum hoses and electrical wiring that may have been disturbed or re-routed during kit installation to be sure that hoses are not kinked, that they do not touch any high temperature item, and that they do not interfere with any linkage components.

NOTE: This kit is designed to operate successfully with the standard fan supplied by the manufacturer of your truck. Due to O.E.M. assembly tolerances, visually make certain that there is adequate clearance between fan and drive pulley, and also between fan and radiator. If there is little clearance to the radiator, check to insure that it will not flex into the radiator before operating. It is not uncommon for radiator to flex toward fan while driving at highway speed or through rough terrain.

CMKF00-730M-A-AC

2000-01 Ford 7.3 Diesel

F-650,750

W-WO/AC, WO/Air brakes

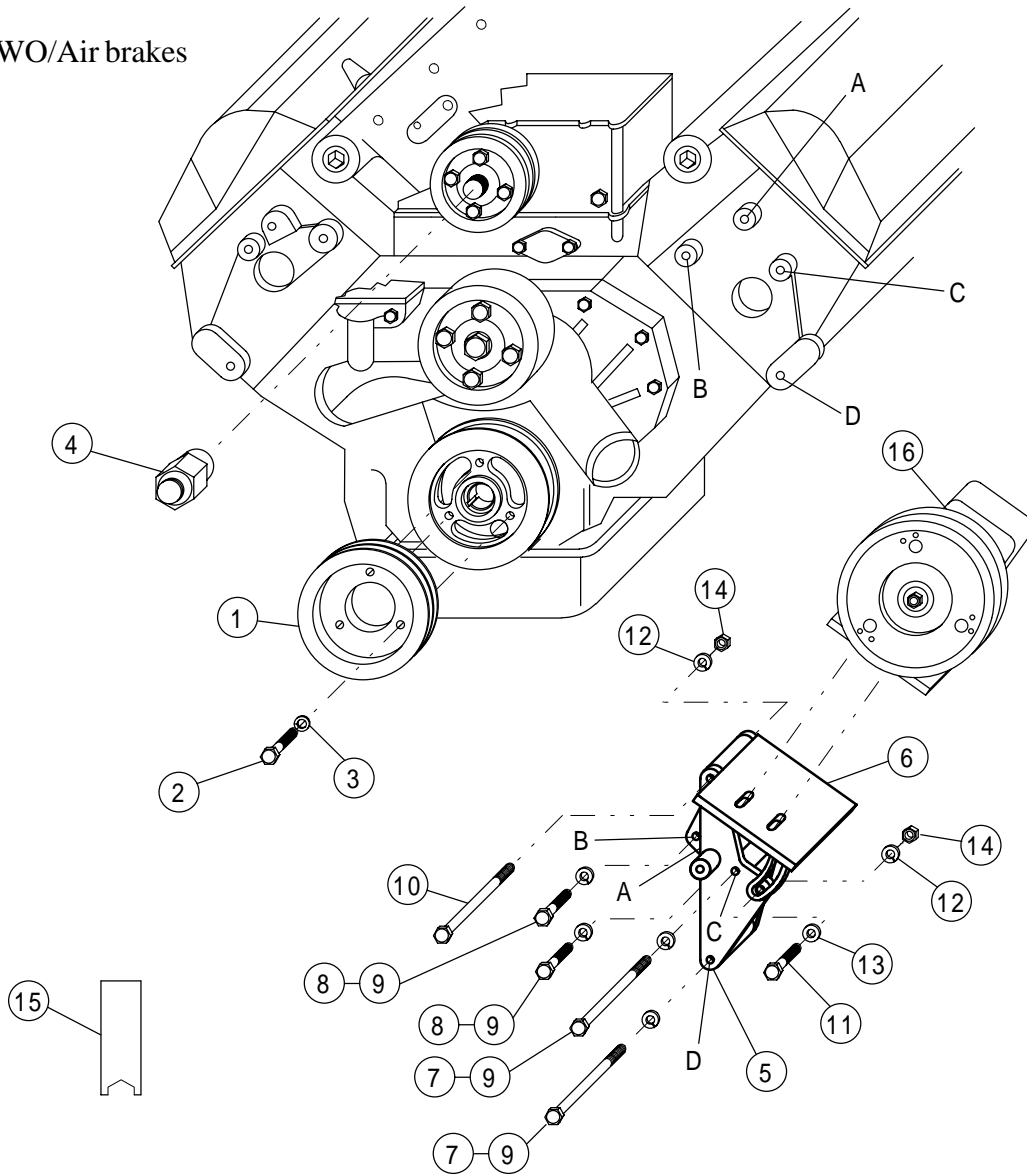

PARTS LIST

- | | |
|--|---|
| 1. IPC 622 (1) | 10. 3/8 x 4-1/2 NC (1) |
| 2. 10mm x 55 mm 1.5 (3) | 11. 3/8 x 1-1/2 NC (1) |
| 3. 10mm LW (3) | 12. 3/8 LW (2) |
| 4. FSK 7392 (1), FSK 52 (1) (<i>discard whichever is not needed</i>) | 13. 3/8 FW (1) |
| 5. IMB 620 (1) | 14. 3/8 NC Nut (2) |
| 6. IMP 62(0-4) (1) | 15. Wrench (1) |
| 7. 10mm x 130mm 1.5 (2) | 16. Clutch Pump Assembly (1)
(Sold Separately) |
| 8. 10mm x 40 mm 1.5 (2) | 17. Belts (Not Shown) (2)
Dayco AX-61
H.D.: Dayco AX-63 |
| 9. 10mm LW (4) | |