



**Muncie<sup>®</sup>  
Power  
Products**

**CMKF01-3126-A-AC**

**CMKF01-3126-AH-AC**

**2001 Ford Truck 650 & 750**

**CAT 3126, W-WO/AC**

*with engine serial# 8YL82469 & higher*

## INSTALLATION NOTES

---

1. Disconnect negative battery cable. Drain the coolant from the radiator and remove the 1" diameter hose from the upper radiator tank. Remove the air intake tube at the air cleaner and the radiator. Remove the fan with a 1-3/4" and 1-7/8" wrench. Threads are left handed. Remove the O.E.M. serpentine belt, it will not be reused. Remove the six bolts from the fan pulley, remove the pulley. The OEM pulley bolts will be reused.
2. Remove the alternator, the spring tensioner, and if equipped, the upper A/C compressor bolt. Loosen the lower A/C bolt but do not remove. Remove the four bolts at locations "A,B,C,D" and remove the cast bracket from the front of the engine (the bolts will be reused). Remove the three bolts from the spindle bearing retaining ring. Remove the spindle and bearing assembly and install it in the new bracket, torque the bolts to (25 ft./lbs.). Remove the alternator bushing from the OEM bracket and install it in to the new bracket.
3. Install the new bracket assembly (2) onto the engine with OEM bolts at locations "A,B,C,D", do not tighten. Install brace (4) with bolts (9) and lockwasher (8) at location "E" on the engine, and through the recessed hole in the front of the bracket. Tighten bolts at all five locations evenly and torque to (40-45 ft./lbs.). Install brace (3) with bolts (7 & 9), and lockwashers (8) and not (10), tighten bolts securely. It will be necessary to bend the metal tab down that keeps the exhaust bolts from turning. Install the alternator using the OEM bolts. If equipped with A/C, use the mounting hole on the compressor that is on the same side as the lower mount. Use OEM bolt and nut. Install the new drive pulley with OEM pulley bolts, torque them to 25 ft/lbs.. Install the tensioner and the new belt.  
**NOTE:** It may be necessary to bend the A/C lines so the compressor can swing out far enough.
4. Install the pump plate onto the bracket using bolts (14 & 15), lockwashers (12), nut (13), and adjustment slide (6) with the slot to the top. Install the pump onto the plate with the bolts provided, align clutch pulley with the drive pulley and tighten bolts. Install the pump belts and tension properly using the jack bolt. Tighten jam nut. Replace the fan. Replace the 1" diameter hose from the truck with the longer hose from the kit. Use O.E.M. clamps and make sure the hose does not come in contact with clutch pump pulley. Replace the air duct. It may be necessary to heat the air tube where it passes the back of the pump and push it in to provide enough clearance. Replace antifreeze. Connect battery cable.

**CAUTION:** Check all engine compartment vacuum hoses and electrical wiring that may have been disturbed or rerouted during kit installation to be sure that hoses are not kinked, that they do not touch any high temperature items, and that they do not interfere with any linkage components.

**CMKF01-3126-A-AC**  
**CMKF01-3126-AH-AC**

2001 Ford Truck 650 & 750

CAT 3126, W-WO/AC

with engine serial# 8YL82469 & higher

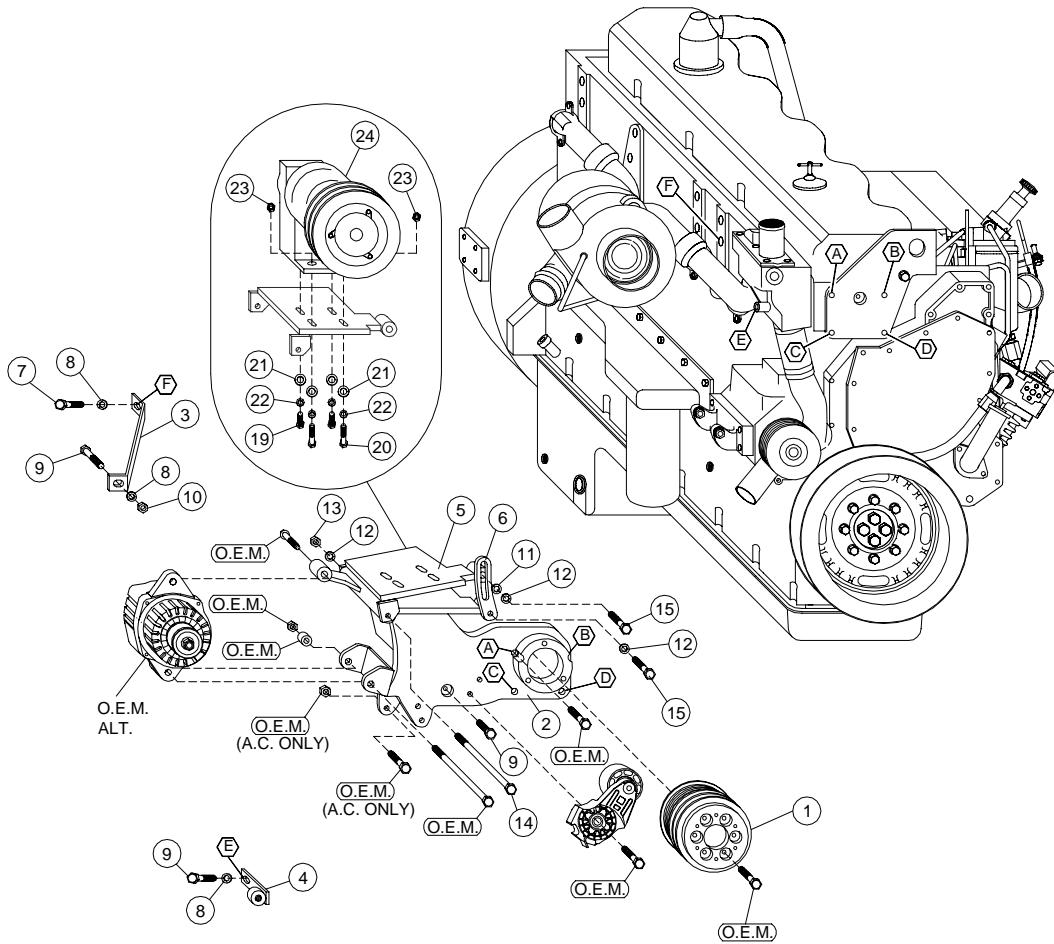

**PARTS LIST**

- |                         |                                     |
|-------------------------|-------------------------------------|
| 1. FPC 912 (1)          | 14. 3/8 x 6-1/2 NC (1)              |
| 2. FMB 920 (1)          | 15. 3/8 x 1-1/4 NC (2)              |
| 3. FMB 921 (1)          | 16. 1" heater hose (Not Shown)      |
| 4. FMB 922 (1)          | 17. Acc. Drive Belt (Not Shown) (1) |
| 5. FMP 911 (1)          | Dayco 5080830                       |
| 6. FMB 912 (1)          | 18. Pump Belts (Not Shown) (2)      |
| 7. 10mm x 25mm Bolt (1) | Dayco AX-46                         |
| 8. 10mm LW (3)          | #2 AX-45, #4 AX-44                  |
| 9. 10mm x 30mm Bolt (3) | 19. 3/8 x 1 NC (2)                  |
| 10. 10mm Nut (1)        | 20. 3/8 x 1-1/2 NC (2)              |
| 11. 3/8 FW (1)          | 21. 3/8 FW (4)                      |
| 12. 3/8 LW (3)          | 22. 3/8 LW (4)                      |
| 13. 3/8 NC (1)          | 23. 3/8 NC Nut (2)                  |
|                         | 24. Clutch Pump Assembly            |
|                         | (Sold Separately)                   |