



**Muncie®  
Power  
Products**

**CMKF03-600A-ZP8-AC**

**2003-2007 Ford Truck F-250-550**

**6.0 Diesel**

**W-WO/AC, WO/Dual Alt.**

## **INSTALLATION NOTES**

---

1. Disconnect the negative battery cables. Drain the engine coolant. Remove the upper radiator hose and overflow tube from the radiator. Disconnect the fan clutch wire. Remove the two bolts from the fan shroud. Using a flat bar against the top of the radiator, pry up on the fan shroud to free it from the diffuser. Raise the fan shroud approximately one foot. With the fan shroud raised, remove the fan clutch wire harness from the fan diffuser so the fan shroud can be removed completely without breaking the plastic wire support. Remove the five bolts from the fan diffuser (2004 and newer models only use four bolts), remove the fan from the water pump (*fan clutch has right hand threads*), then remove the diffuser and fan together from the engine compartment. Remove the passenger side air to air charge air cooler tube.
2. Remove the glow-plug module and module bracket located on top of the passenger side valve cover. Remove the three nuts that hold the M.A.P. sensor and bracket to the top of the heating housing (retain the three nuts). Remove the M.A.P. sensor from its' bracket and install it onto the new bracket (30) according to the drawing with the O.E.M. screws. Replace the vacuum hose that runs from the engine to the M.A.P. sensor with the longer hose provided in the kit. Reuse the hose clamps and protective cover. Mount the new bracket back onto the heater housing with the O.E.M. nuts. Remove some of the tape from the wiring harness where the wires from the sensor located in the valve cover enter the harness. Mount the module onto bracket (30) with bolts (31) and nuts (32). **CAUTION:** Make certain not to strain any wires or wire connectors, then secure them with tie straps. Remove the nut holding the transmission dipstick tube to the valve cover bolt. Install the dipstick tube brace (33) onto the stud with the OEM nut. Install the dipstick onto the brace with nut (32). This should allow enough clearance to run the hydraulic hoses between the transmission dipstick tube and the engine oil fill spout.
3. Remove the OEM serpentine belt and tensioner. Install bracket (12) onto the passenger side cylinder head at locations "A", "B", "C" & "D" with bolts (13,14). Note: The wiring harness located on the front of the cylinder head must go behind the bracket. Torque bolts to 40 ft/lbs.. Reinstall the OEM tensioner. Install idler (15) onto bracket (12) with bolt (16). Remove the OEM idler at location "F". Remove the bolt and washer from the idler. Install the idler back to it's original location re-using OEM washer (4) and stud (5). (Torque to 35 ft/lbs.). Install the cooler tube rest bracket (34) onto the alternator with the OEM bolts as shown in the illustration. Install the new accessory drive belt onto the engine and route it the same as a vehicle with the dual alternator option. (*See belt diagram on the trucks radiator support*).
4. Install drive pulley (1) onto the balancer with bolts (2), torque to 40ft/lbs. Install bracket (3) with bolts (6) and nut (7). Torque bolts and nut to 40 ft/lbs. Install idler (9) onto bracket (3) with bushing (8), flatwasher (10), and bolt (11).

*(continued on back side)*

5. On '03-'04 models, remove the passenger side battery. With a suitable tool, cut the flange with the two holes in it from the battery tray. Remove any sharp edges. Reinstall the battery, and move it as close to the fender as possible.
6. On 2003 models equipped with A/C: the A/C line coming from the receiver dryer will need to be bent outward to run down along side the battery. It is easiest to bend the line by standing on the passenger side of the vehicle, place your left hand on the A/C line right where it comes out of the receiver dryer, and your right hand where the rubber hose is crimped onto the aluminum tube. Pull the A/C line towards you with your right hand until the rubber hose just comes in contact with the battery cables. Secure the A/C line to the battery cables with tie straps. The A/C line coming from the condenser will need to be bent outward and to clear the new cooler tube.
7. Install the clutch pump onto the bracket with bolts (19) lockwashers (20) and nuts (21). Install coil adapter (23) onto bracket (12) with bolts (24). Install coil and clutch as per manufacturer's instructions. Tighten bolts securely. Install tensioner (17) onto the bracket with bolt (18). Install pump drive belt according to belt diagram.
8. Cut the fan diffuser as necessary to clear the drive pulley, idler and clutch pump. Use the diagram supplied with this kit for diffuser cut out lines. If cutting the diffuser is not desirable, a diffuser for a 6.0 liter with the dual alternator option is available from Ford Motor Co. as a replacement. The part# is 4C3Z-8B614-BB.  
Install the diffuser and fan. Install the fan shroud, upper radiator hose and overflow tube. Install the 90° rubber elbow onto the air to air charge air cooler with the opening pointing straight up. Install the 3" 90° steel tube with the small end down into the rubber elbow. Install the O.E.M. rubber adapter and 2 1/2" steel tube (the long end goes on the turbo). Align the cooler tube then tighten the clamps securely.  
**IMPORTANT:** Install the OEM coupler clamps with the adjustment bolt on the bottom side of the tube. If the cooler tube comes in contact with the hood insulation, remove the insulation from above the tube.
9. Replace the antifreeze and connect the battery cables. Run the engine and check for proper belt tracking and clearances.

# CMKF03-600A-ZP8-AC

2003-2007 Ford Truck F-250-550

6.0 Diesel

W-WO/AC, WO/Dual Alt.

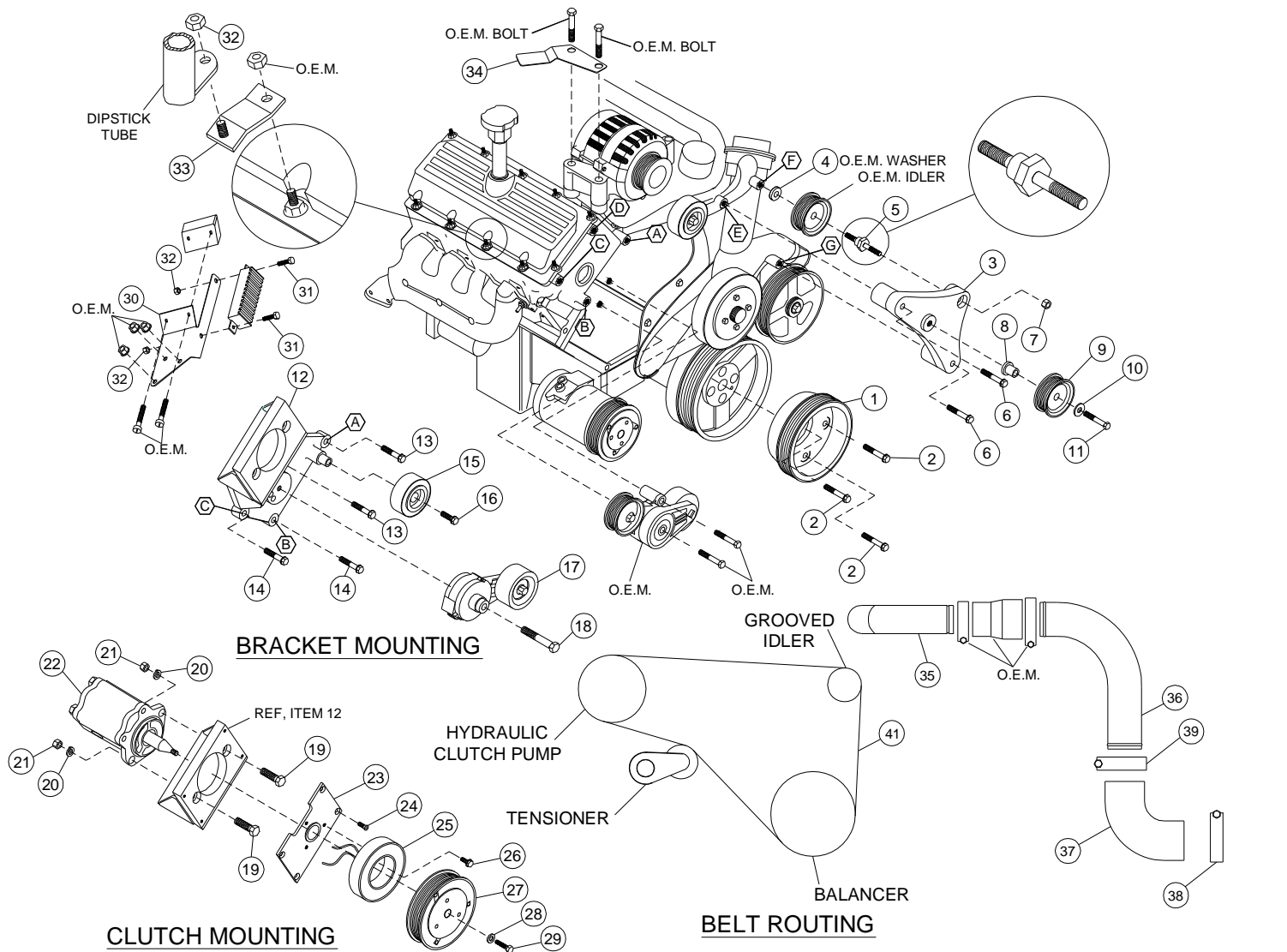

## PARTS LIST

- |                                   |   |   |
|-----------------------------------|---|---|
| 1. FPC 688 (1)                    | 17. 8920236 Tensioner (1)                     | 30. FMB 689 (1) Module Bracket                        |
| 2. 10mm x 30 Flg Hd 10.9 (3)      | 18. 12mm x 80 10.9 (1)                        | 31. 1/4 x 3/4 NC (2)                                  |
| 3. FMB 680 AL (1)                 | 19. 3/8 x 1 1/2 NC (2)                        | 32. 1/4 Nut NC (3)                                    |
| 4. OEM Washer (1)                 | 20. 3/8 LW (2)                                | 33. FMB 688 (1) Dipstick Tube Brace                   |
| 5. 1080ST (1)                     | 21. 3/8 Nut NC (2)                            | 34. FMB 687 (1) Cooler Tube Rest                      |
| 6. 10mm x 80 Flg Hd 10.9 (2)      | 22. Clutch Pump Assembly<br>(Sold Separately) | 35. 2.5-85-ST 2 1/2" Steel Elbow (1)                  |
| 7. 10mm Flg Nut (1)               | 23. MCA01 Clutch Mtg Plate (1)                | 36. 3-90-ST 3" Steel Elbow (1)                        |
| <b>GPKDF68AL Assy: Items 8-11</b> | 24. 1/4 X 3/4 NC FHSCS (4)                    | 37. TP 140 Rubber Elbow (1)                           |
| 8. FMB 684-1 (1)                  | 25. Coil (Sold Separately)                    | 38. 250-87 Hose Clamp (1)                             |
| 9. GPCD 8 (1)                     | 26. Capscrew-19T34530 (3)<br>(t=8-10ft/lbs)   | 39. 250-84 Hose Clamp (1)                             |
| 10. 12mm FW (1)                   | 27. Clutch (Sold Separately)                  | 40. K81325 Dayco (1) (Main Drive belt)<br>(Not Shown) |
| 11. 12mm x 65 10.9 (1)            | 28. Flat Washer-21MZ3487 (1)                  | 41. 5080725 Dayco (1) (Pump Drive belt)               |
| 12. FMP 68A AL (1)                | 29. Capscrew-19T38756 (1)<br>(t=20ft/lbs)     | 42. Plastic Tie Straps (Not Shown)                    |
| 13. 10mm x 50 Flg Hd 10.9 (2)     |   | 43. 1/4"x20" Vacuum Hose                              |
| 14. 10mm x 40 Flg Hd 10.9 (2)     |   |   |
| 15. 89016 Dayco (1)               |   |   |
| 16. 10mm x 30 Flg Hd 10.9 (1)     |   |   |

# '03-'07 Ford 6.0L Diesel Diffuser Cut-Out

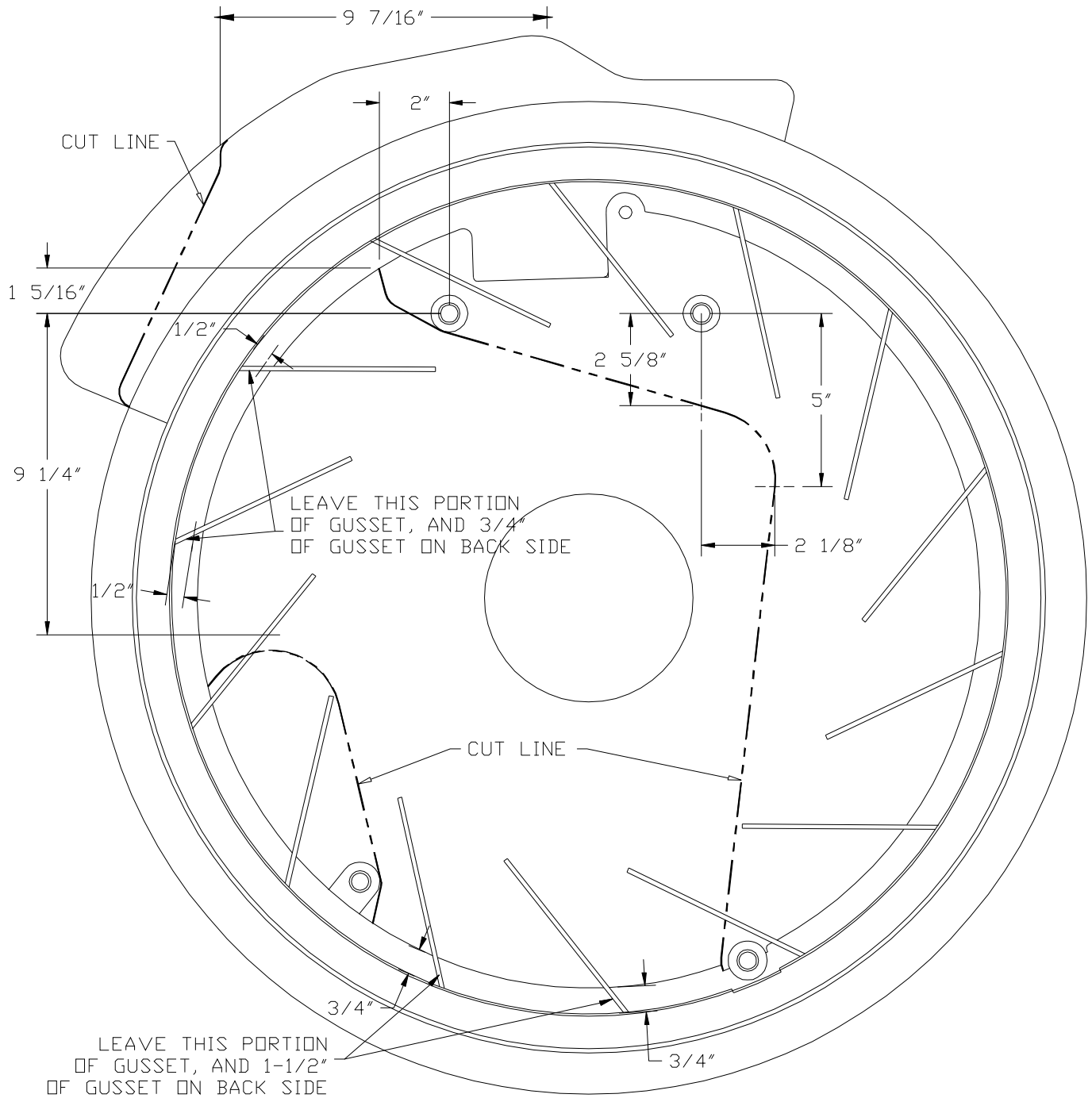

**VIEW FROM FRONT**