



**Muncie[®]
Power
Products**

CMKF04-590M-YP8

2004-05 FORD 650-750

5.9 L CUMMINS

W/O AC, W-W/O AIR BRAKES

INSTALLATION NOTES

1. Disconnect negative battery cable. Remove OEM belt and tensioner. Install bolts (5) with lockwashers (6) into plate (1) as shown in the illustration. Install plate (1) onto the engine with bolts (4) into the air conditioner location. Tighten bolts securely. Install A-mount adapter plate (2) onto plate (1) with bolts (5). Do Not Tighten.
2. Install pump (14) onto the adapter plate (2) with bolts (9), flatwashers (10), and lockwashers (6), nuts (11). Tighten bolts securely. Install coil adapter (15) onto plate (2) with bolts (16). Install the coil and clutch per manufacturer's instructions. Using a straight edge, make certain the clutch pulley is parallel with the accessory pulleys, then tighten bolts (5) securely. Install both gussets (3) with bolts (7) and lockwashers (8), tighten bolts securely.
3. Install the new tensioner (12) onto the lower tensioner mounting location using bolt (13). Install the new belt (22) onto the engine according to the belt diagram. Check all hoses, wires, etc., that may have been disturbed during installation to make sure they do not come in contact with any hot or moving parts.

CMKF04-590M-YP8

2004-05 FORD 650-750

5.9 L CUMMINS

W/O AC,

W-W/O AIR

BRAKES

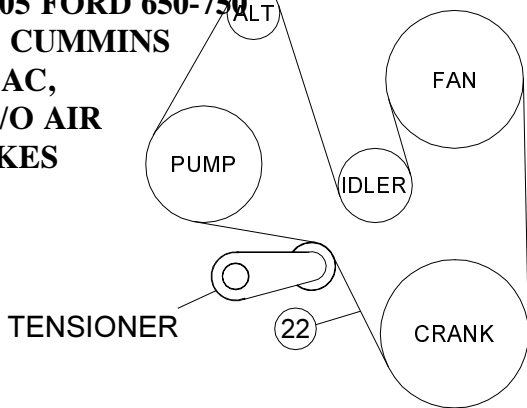

BELT ROUTING

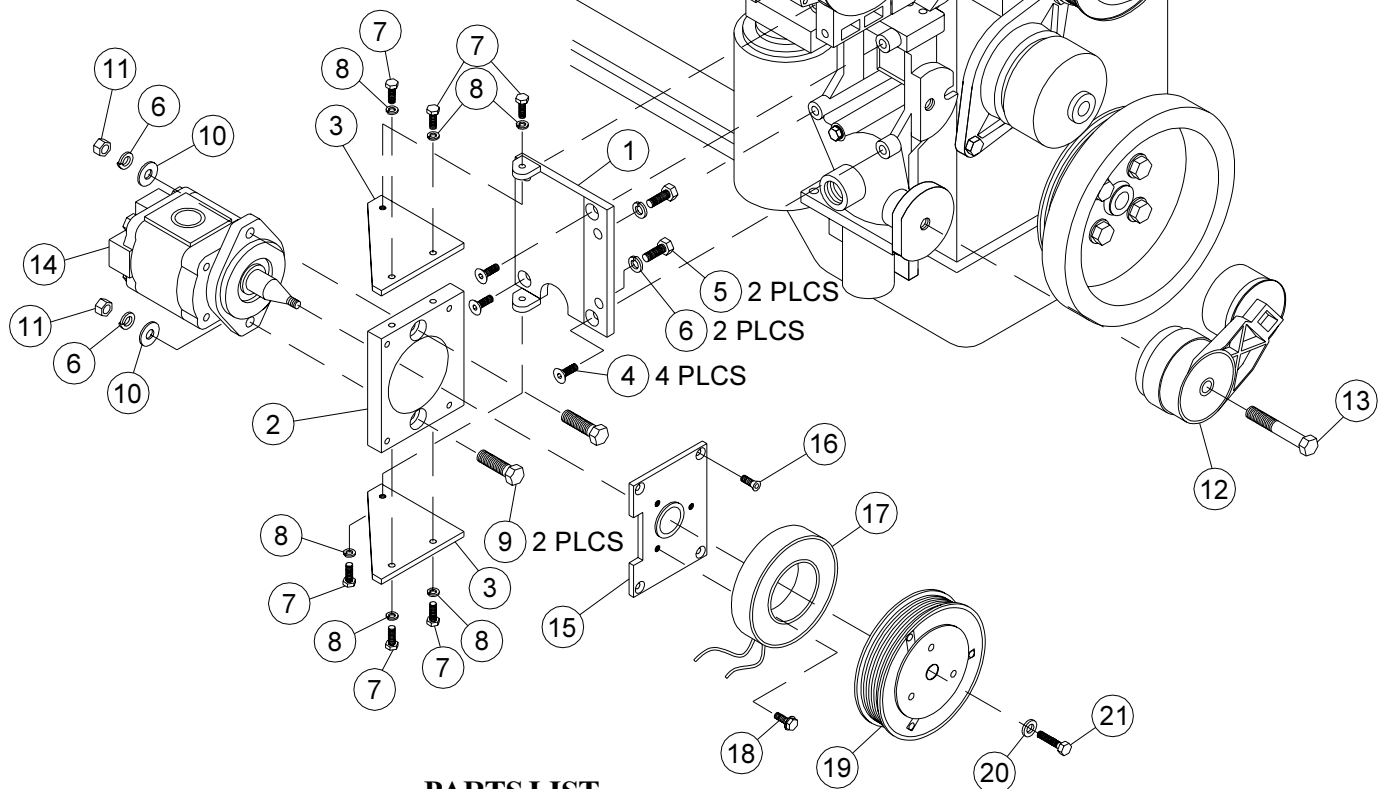

PARTS LIST

- | | |
|--|--|
| <ul style="list-style-type: none"> 1. FMP 53A18 (1) 2. PBL2M (1) 3. FMB53I81 (2) 4. 8mm x 50mm FHSCS (4) 5. 3/8 x 1 Bolt (2) 6. 3/8 LW (4) 7. 1/4 x 3/4 Bolt (6) 8. 1/4 LW (6) 9. 3/8 x 1-1/2 Bolt (2) 10. 3/8 FW (2) 11. 3/8 Nut (2) 12. 89200B Tensioner 13. 10mm x 80mm 10.9 (1) | <ul style="list-style-type: none"> 14. Clutch Pump Assembly
<i>(Sold Separately)</i> 15. MCA01 Clutch Mtg Plate (1) 16. 1/4 X 3/4 NC FHSCS (4) 17. Coil <i>(Sold Separately)</i> 18. Capscrew-19T34530 (3)
(t=8-10 ft/lbs) 19. Clutch <i>(Sold Separately)</i> 20. Flat Washer-21MZ3487 (1) 21. Capscrew-19T38756 (1)
(t=20 ft/lbs) 22. Belt; Dayco 5080820 (1) |
|--|--|