



**Muncie[®]
Power
Products**

CMKF08-6401-P8-AC

2008-Current Ford F-250-550

6.4L Diesel

W-WO/AC, W/Dual Alt.

WO/Vacuum Pump

INSTALLATION NOTES

1. Using a 8mm socket or wrench, disconnect the negative battery cables first, disconnect the positive cables and remove the battery hold downs. Remove both batteries from the vehicle. Remove the two bolts from the power steering reservoir and lift it from its cradle. Remove the four bolts from the top half of the fan shroud. (Do not try to remove the fan shroud at this time) To protect the coolers, cut two pieces of cardboard, one 24" X 24" and one 24" X 36". Slide the 24 X 36 inch piece between the A/C condenser and the transmission cooler, and the 24 X 24 inch piece between transmission cooler and the CAC (charge air cooler).
2. Using a 10mm socket or wrench, remove the two upper CAC bolts, the transmission cooler bolts and the hood latch bolts. Disconnect the horns, remove the bolt holding them to the radiator support and remove the horn and bracket assembly from the vehicle. Remove the plastic clips holding the hood latch cable the to the radiator support. Remove the upper radiator support bolts and clamps from each side of the radiator. Using a 13mm socket or wrench, remove the three radiator support bolts from each side of the radiator support. While pushing the top of the radiator towards the cab, lift up on the radiator support and remove it from the vehicle. Using a 11mm deep well socket, loosen the two right hands CAC tube clamps and remove the tube. Remove the top half of the fan shroud from the vehicle.
3. Disconnect the cooling fan clutch electrical connector. Unclip and position the fan wiring aside. Using a fan nut tool, remove the cooling fan and clutch. **IMPORTANT** (fan nut has left hand threads). Gently pulling the radiator forward for clearance, lift the fan and clutch assembly from the vehicle. Use extreme care not to damage the radiator with the fan during removal. Using a 13mm socket, remove the two upper nuts and two lower bolts from the fan diffuser and remove it from the vehicle. Remove the air cleaner assembly by taking loose the hose clamp on the intake duct and removing both wiring plugs. Simply pull up on the hose side of the air cleaner and remove. Remove the passenger side battery box by removing all four bolts, partially moving to the side and removing the washer fluid line and wire connector.
4. Remove the O.E. 8-groove serpentine belt and tensioner. Release the tension on the A/C belt and remove the A/C tensioner. The A/C belt can be left on the truck. Remove the two flat idlers from the engine. Remove the two nuts and two bolts holding the alternator bracket to the engine. Slide the bracket forward on the studs to gain access to the alternator wiring. Disconnect the alternator wires and remove the alternators and bracket assembly from the engine.
5. With a suitable tool, remove a portion of the righthand side battery box as show in the illustration on the back sheet. This is done to gain clearance to the clutch pump. Remove the alternators from the alternator bracket.



CMKF08-6401-P8-AC

2008-Current Ford F-250-550

6.4L Diesel

W-WO/AC, W/Dual Alt.

WO/Vacuum Pump

6. Install both alternators onto the new bracket (3) using bolts (2), lockwashers (5) and flatwashers (4). Install the bracket assembly onto the engine reusing the O.E. studs. Connect the alternator wires before sliding the bracket all the way back (power wire will need lengthened for lower alternator). Secure the bracket reusing the O.E. bolts and nuts. Torque nuts and bolts to 40-45 ft-lbs.. Install the pump (24) onto the bracket (3) using the bolts (18) and lockwashers (17).
7. Install the A/C tensioner and belt onto the new bracket with the O.E. bolt. Install the O.E. idler with the washer on it onto the engine at its original location. Install the drive pulley (1) onto the engine dampener using bolts (2) and lockwashers (5). Torque them to 45-50 ft-lbs.. Using a straight edge, align the pump with the drive pulley and secure the pump bolts.
8. Reinstall O.E. idler in location "A" using bolt (8), flatwasher (7), and spacer (6) Install the O.E. tensioner onto the bracket in the center location and install the O.E. belt as shown in the diagram. **When installing the engine belt, do not push the tensioner all the way down. The tensioner will go past center and make belt installation difficult.** Install inside grooved idler (10) using bolt (14), flatwasher (13), and spacer (12). Install outside grooved idler (10) using bolt (11) flatwasher (7) and bushing (9). Install the pump belt tensioner (15) using bolt (16). Install the pump belt (23). Using a suitable tool, remove the portion of the diffuser that comes in contact with the pump, tensioner and belt. This may include most of the passenger side of the diffuser between the upper and lower bolts. Install fan spacer (19).
9. Install battery box by installing bolts (21,22) through battery box tray (20). Drill 1/4" hole and install A.C. line to battery box with wire loom clamp (25), bolt (26), nut (27), FW (28), and LW (29).
10. Replace the fan diffuser using spacers (30) on the top two studs. Install fan. Fan nut gets torqued to 96 ft.-lbs.. Connect the fan clutch wire. Replace the fan shroud. Install the CAC tube and torque the clamps to 11 ft-lbs. Replace the radiator core support and torque the bolts to 46 ft-lbs. Replace the radiator support clamps. Replace the transmission cooler and remove the cardboard from the vehicle. Replace the hood latch, use the washer marks on the latch to properly align the hood latch. Note: The hood latch bolts have serrated washers on them. Replace the power steering reservoir. Install and connect the batteries.

NOTE: Check all wires, hoses, etc. that may have been disturbed during assembly to ensure they do not come in contact with any hot or moving parts. It is the installer's responsibility to make sure proper clearances are obtained to prevent engine or component damage.

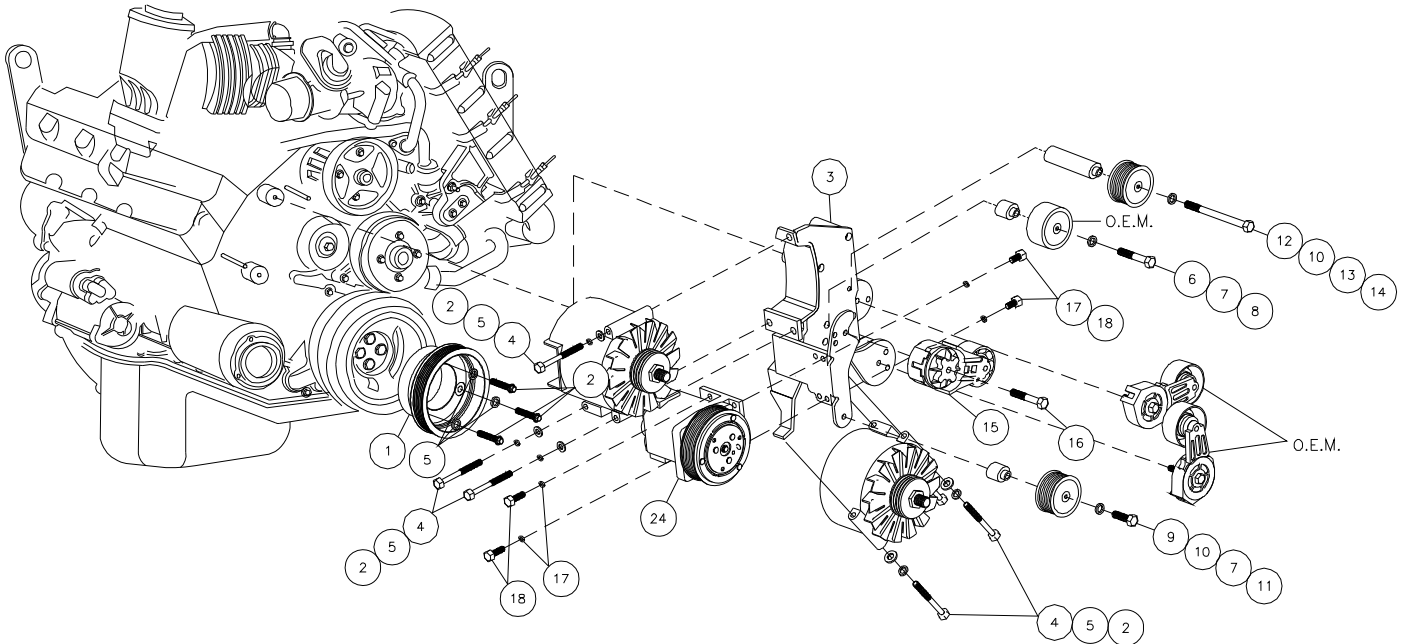

PARTS LIST

1. FPC 2608M (1)
2. 10mm x 75mm Bolt (9)
3. FMP 2601-8DA (1)
4. 10mm Flatwasher (6)
5. 10mm Lockwasher (9)
6. FMB 2601DA (1)
7. 12mm Flatwasher (2)
8. 12mm x 65mm Bolt (1)
9. FMB 2602DA (1)
10. GPCS8 (2)
11. 12mm x 45mm Bolt (1)
12. FMB 2603DA (1)
13. 3/8 Flatwasher (1)
14. 10mm x 120mm Bolt (1)
15. Dayco 89426M (1)
16. 10mm x 75mm Mod Bolt (1)

17. 3/8 Lockwasher (4)
 18. 3/8 x 1-1/4 Bolt (4)
 19. FSK260 Fan Spacer (1)
- ITEMS 20-22 AND 25-30 NOT SHOWN*
20. FMB 2604DA Battery Box Tray (1)
 21. 8mm x 40mm FHSCS (1)
 22. 8mm x 45mm FHSCS (1)
 23. Dayco 5080775 (1)
 24. Muncie Clutch Pump (1)
 25. #10 Wire Loom Clamp (1)
 26. 1/4 x 3/4 Bolt (1)
 27. 1/4 Nut (1)
 28. 1/4 Flatwasher (1)
 29. 1/4 Lockwasher (1)
 30. SP64-.750 (2)

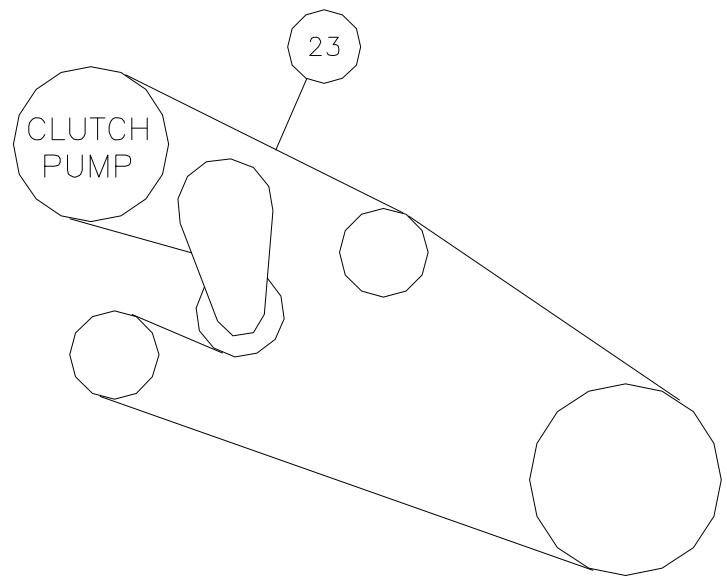
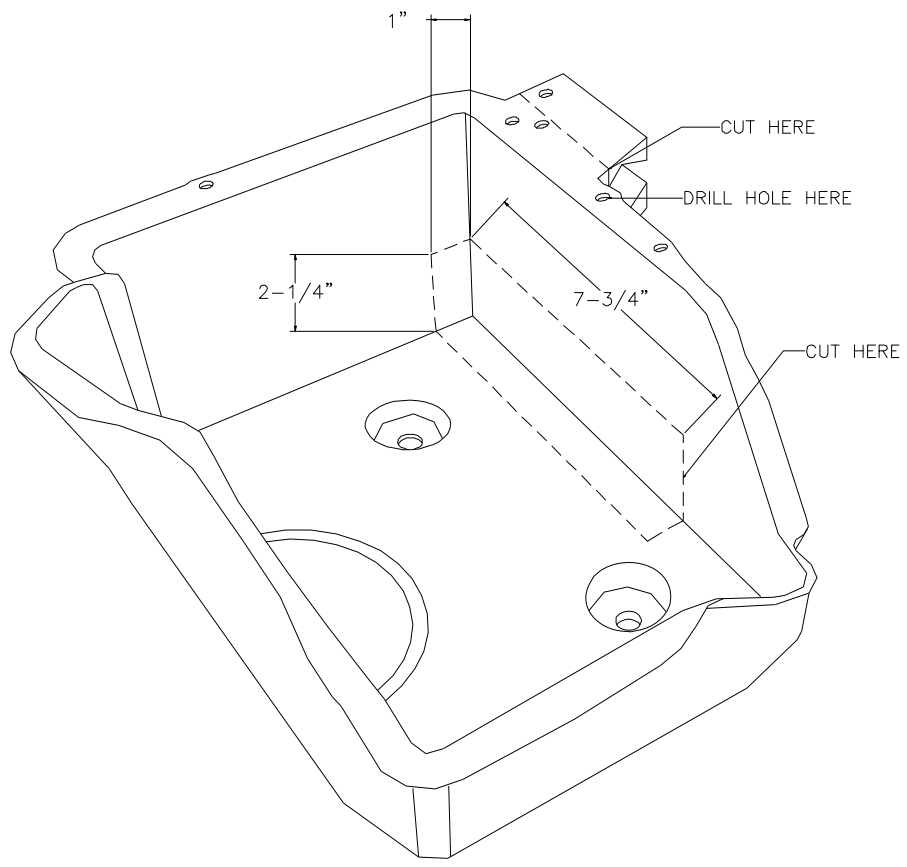

BELT ROUTING
CMKF08-6401-P8-AC