



**Muncie®  
Power  
Products**

**CMKF11-6701-YP8-AC**

**2011-Current Ford 650 & 750**

**6.7L Cummins**

**W/AC, W-W/O Air Brakes**

---

## **INSTALLATION NOTES**

---

1. Disconnect negative battery cables. Remove the turbo cooler tube from the passenger side engine compartment. Remove the O.E.M. belt, alternator, alternator bracket, and lifting lug from the passenger side of the engine.
2. Install the pump bracket (1) with bolts (2). Torque bolts to 40 ft/lbs. Remove the top two air conditioner mounting bolts. Install bracket (3) with bolts (4) and lock washers (5). Do not tighten. Install bolts (6). Tighten bolts (5) and (6) finger tight; then torque bolts (5) to 25 ft. lbs. and bolts (6) to 40 ft. lbs.
3. Install the pump into bracket (1) with bolts (7), lock washers (8), and nuts (9). Install the coil and clutch as per manufacturer instructions. Install idlers (13), bushings (14), and bolts (15) onto the bracket with the bottom idler in the upper hole. Torque bolts to 30 ft. lbs. Install the O.E.M. alternator with lock washers (11), spacers (10), and bolts (12). Torque bolts to 30 ft/lbs. Install the new belt (24) according to the belt diagram. If the belt is too short, move the bottom idler down a hole. Install O.E.M. turbo tube and align for best fit then tighten clamps securely.
4. Use the plastic tie straps supplied in the kit to secure any hoses, wires, etc., that may come in contact with any hot or moving parts. Reconnect battery cables. Run engine and check for proper belt tracking and clearances.

**NOTE:** Check all engine compartment vacuum hoses and electrical wiring that have been disturbed or re-routed during kit installation to be sure that hoses are not kinked, that they do not touch any high temperature item, and that they do not interfere with any linkage components.

# CMKF11-6701-YP8-AC

2011-Current Ford 650 & 750

6.7L Cummins

W/AC

W-W/O Air Brakes

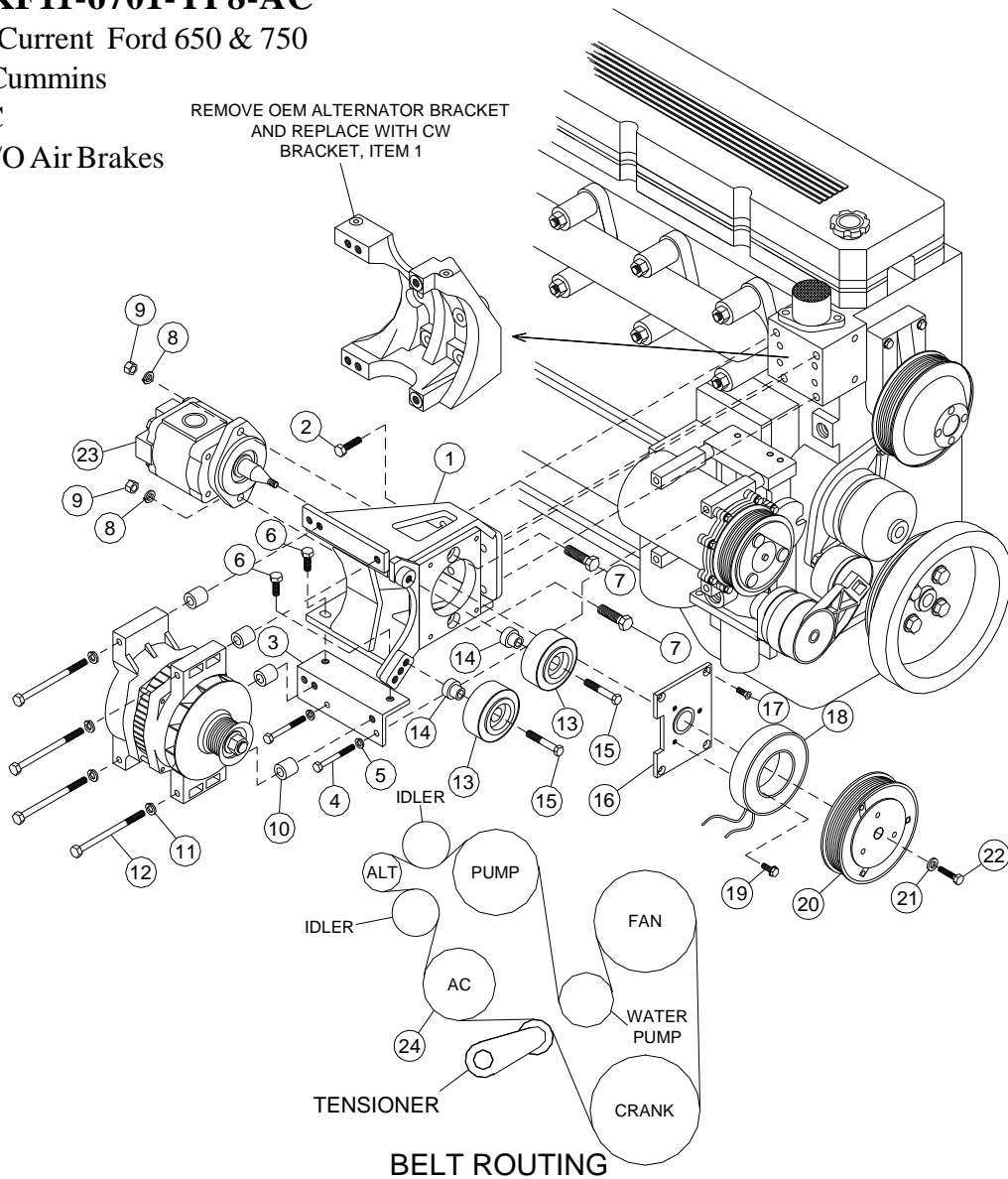

## PARTSLIST

1. FMB 273A (1)
2. 10mm x 30mm Flange Bolt (4)
3. FMB2711 (1)
4. 8mm X 110mm Bolts (4)
5. 8mm LW (2)
6. 10mm X 20mm Flange (2)
7. 3/8 X 1-1/2 (2)
8. 3/8 LW (2)
9. 3/8 Nut (2)
10. SP100-1.00 Spacer (4)
11. 10mm LW (2)
12. 10mm X 120mm Bolt (4)
13. 89016 Idler (2)
14. FMB 2731 Bushing (2)
15. 10mm X 40mm Flange Bolt (2)
16. MCA01 Coil Adaptor (1)
17. 1/4 FHSCS (4)
18. Coil (1)
19. Capscrew 19T34530 (3)  
(t=8-10 ft/lbs)
20. Clutch (1) *Sold Separately*
21. Flatwasher 1411C (2)
22. Capscrew 19T38756 (1)  
(t=20 ft/lbs)
23. Clutch Pump (*Sold Separately*)
24. 5080980 Belt (1)
25. Tie Straps (*Not Shown*)