



**Muncie[®]
Power
Products**

CMKF14-6200-XP6-AC
2014-CURRENT FORD
F250-550 SUPER DUTY
6.2L V8 GAS

INSTALLATION NOTES

1. Disconnect the battery and drain engine coolant enough to remove the upper radiator hose without loosing coolant. Remove the air duct at the engine and air cleaner. Cut the hose off of one end of the crankcase vent quick couplers. It will be reused. Remove the upper radiator hose at the engine. Using a 1/2" ratchet or other suitable tool, depress the tensioner and remove the serpentine belt. Remove the OEM idler from location A. Remove the bolts at locations C,D, and E. Install bracket (1) onto the engine using bolts (4) at locations C,D, and E. (Do not tighten) Install brace (2) with bolt (6) at the engine, and bolts (5) into bracket (1). With all bolts installed finger tight, torque bolts (4) to 25 ft. lbs. Then torque bolt (6) to 40 ft. lbs. and bolts (5) to 25 ft. lbs. **NOTE: On vehicles with black composite valve covers, it will be necessary to trim some plastic from the lower front portion of the valve cover for belt clearance.**

2. Remove bolts from locations F, G, and H. Install studs (16) at all three locations. Slide spacers (15) over studs (16), then install idler bracket (14) using nuts (17). Install the O.E.M. idler that was removed onto bracket (14) using bushing (18) and bolt (19). Install idler (8) at location A with bolt (10) and washer (9). Install belt guard (3) with bolts (7). Do not tighten at this time. Install the pump onto the bracket (1) with bolts (12) and lock washers (13). Align both sides of clutch with the drive pulley using a good quality straight edge and then tighten bolts (12). Install the belt (11) as shown in the belt routing diagram. Adjust the belt guard (3) to obtain 1/8" to 1/4" clearance then tighten bolts (7).

3. Install the upper radiator hose extension (31) using O.E.M. hose clamp onto the thermostat housing then install the upper radiator hose onto it using coupler (30) and hose clamps (32). Install the new air duct as shown in the illustration at the top right of the next page. New vent hose (26) needs to be installed onto the original 45 deg. elbow that was removed earlier using hose clamp (27). To obtain more clearance between the air duct elbow and the clutch, use the spacer and bolt that have been provided in the kit. Remove the rear air cleaner bolt and loosen the front one. Install the spacer (28) in the rear location between the fender and the rubber air cleaner grommet then install the longer bolt (29). Adjust the air cleaner box then tighten the bolts.

4. Replace the engine coolant and connect the battery. Make certain all wires and hoses disturbed during installation do not come in contact with any hot or moving parts. Run the engine and check for proper belt tracking.

CMKF14-6200-XP6-AC

2014-CURRENT FORD
F250-550 SUPER DUTY
6.2L V8 GAS

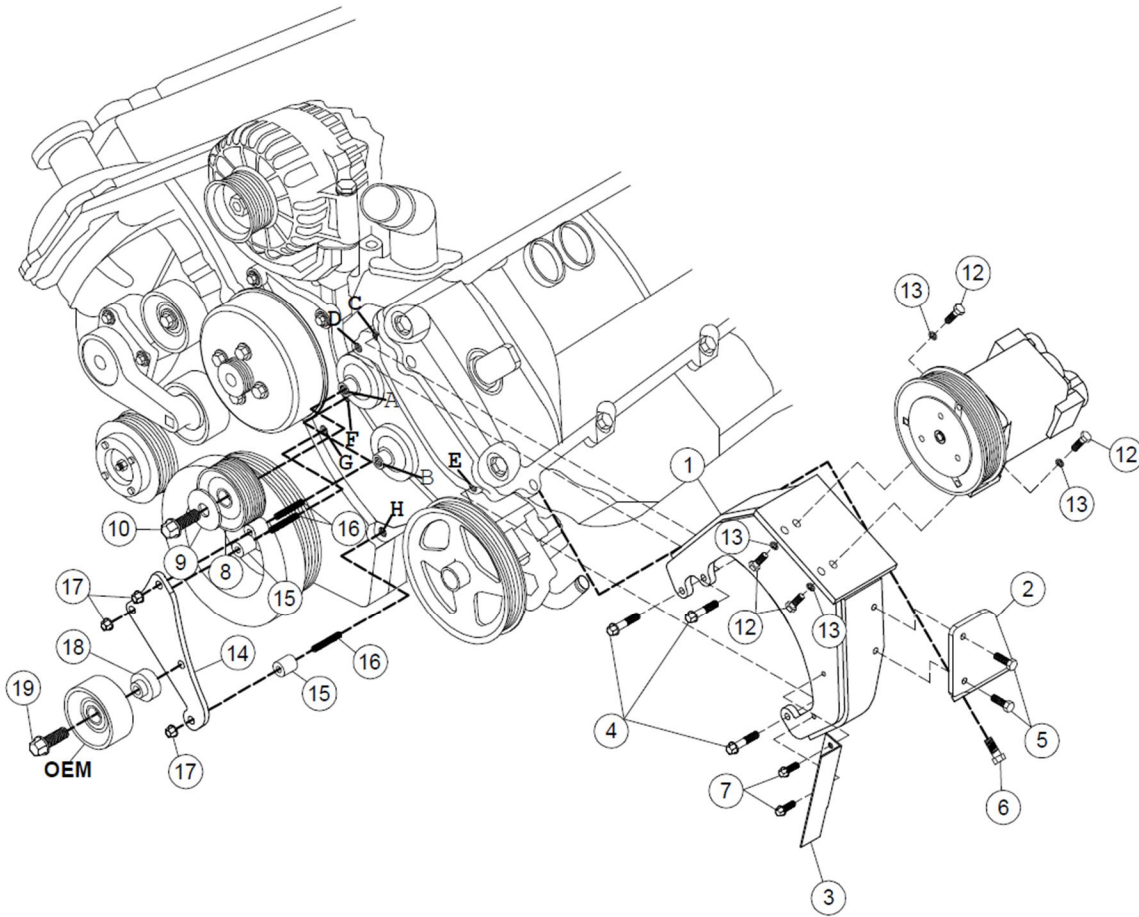
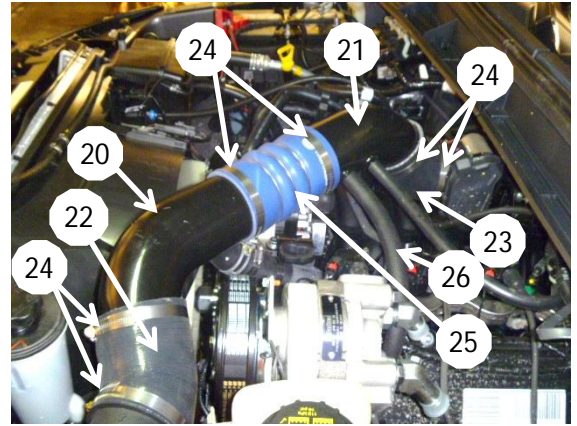
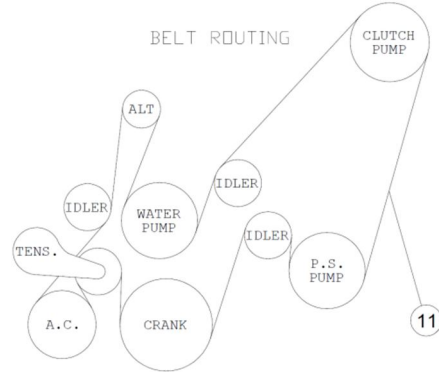

PARTS LIST

- | | | |
|---------------------------|------------------------------|---------------------------------------|
| 1. FMP481-I6 (1) | 12. 3/8 x 1 (4) | 23. TP1189-02MOD (1) |
| 2. FMB481-I6 (1) | 13. 3/8 Lock Washer (4) | 24. #56 Hose Clamp (6) |
| 3. FMB482-I6 (1) | 14. FMB493-I6 (1) | 25. TCA352 (1) |
| 4. 8mm x 50mm Flange (3) | 15. SP64-1.00 (3) | 26. 5/8" x 12" Hose (1) |
| 5. 8mm x 20mm Flange (2) | 16. 8mm x 80mm Set Screw (3) | 27. #10 Hose Clamp (1) |
| 6. 16mm x 30mm (1) | 17. 8mm Flange Nut (3) | <u>Items (28-32) Not Shown</u> |
| 7. 8mm x 12mm Flange (2) | 18. CMB3876 (1) | 28. FMB494-I6 Spacer (1) |
| 8. 89051 Dayco (1) | 19. 10mm x 40mm Flange (1) | 29. 8mm x 30mm Flange (1) |
| 9. FMB483-I6 (1) | 20. FMB491-I6 (1) | 30. DMB402(1-1/2" Coupler) (1) |
| 10. 8mm x 25mm Flange (1) | 21. FMB492-I6 (1) | 31. 1-1/2" x 2-3/4" Hose (1) |
| 11. 5061265 Dayco (1) | 22. TP1189-01MOD (1) | 32. #24 Hose Clamp (2) |