



**Muncie®
Power
Products**

CMKF23-67DA-P6-AC

2023 (Build Date: 01.01.2023 or Later)-2024 Ford F-250-F-550, F-600 Super Duty
6.7L V8 PowerStroke Diesel w/ A/C, w/ OEM Dual Alternators,
w/o Ford ProPower Option, w/o Adaptive Steering

Requires 6-Groove Clutch, Muncie PH Series Pad-Mount Pump
NOTE: Must Use Rear Ported Pump
Approximately 130% Overdriven w/ 6" Diameter Clutch

INSTALLATION NOTES

1. The buyer is responsible for providing trained and experienced installation decision making with technical know-how to apply professional judgment that specifically applies to each individual installation.
2. Be sure to read and understand all available information including but not limited to instructions, warnings, sale terms, and warranties for the vehicle and all system components prior to attempting installation.
3. Disconnect the negative battery cables.
4. Remove the air duct from the passenger side of the engine.
5. Remove the charge-air tube from the driver side of the engine.
6. Remove the power steering reservoir from the fan shroud. Then, remove the top half of the fan shroud. It is highly recommended that the radiator be protected with cardboard or other suitable material to prevent damage during this installation.
7. Remove the bolt holding the fan wire standoff to the engine. Then, disconnect the fan wire. Remove the fan (fan nut has right-hand threads). Remove the four nuts holding the fan ring to the engine. Then, remove the fan ring from the vehicle (it is best to rotate the fan ring clockwise until the rubber flap is facing upwards).
8. Remove the OEM belt.
9. Disconnect the wires from the alternator. Then, remove the alternator. Drain as much fluid as possible from the power steering reservoir. Then, remove the hose connecting the power steering reservoir to the power steering pump. Remove the power steering pump from the bracket. Let it lay inside the fan shroud. It is not necessary to remove the steel high-pressure line from the power steering pump. Remove the power steering/alternator bracket from the engine.
10. Remove the plastic wire harness support from the lower-driver side of the engine. It will not be reused. Protect the wire using the wire protectors (19-20) and zip ties (21). Using clamp (17) and bolt (18) secure the wire harness to the engine at mounting location [C].
11. Drain the engine coolant and remove the hose connecting the radiator reservoir to the engine. Remove the plastic hose clamp from the quick disconnect elbow. Remove the hose from the elbow. Replace that hose with hose (22) using clamps (23-24). This hose is replaced to provide clearance to the clutch pump hoses.
12. Rotate the clamp on the fitting that is just to the left of the crank pulley. This is to help avoid it from interfering with the aftermarket belt. On that same hose, roll the protective sleeve down and secure it with a zip tie to keep it from getting into the belt. Refer to the picture for guidance for this step.
13. Install the clutch pump assemblies onto the main bracket (1) using hardware (27-28).



**Muncie®
Power
Products**

CMKF23-67DA-P6-AC

2023 (Build Date: 01.01.2023 or Later)-2024 Ford F-250-F-550, F-600 Super Duty
6.7L V8 PowerStroke Diesel w/ A/C, w/ OEM Dual Alternators,
w/o Ford ProPower Option, w/o Adaptive Steering

Requires 6-Groove Clutch, Muncie PH Series Pad-Mount Pump
NOTE: Must Use Rear Ported Pump
Approximately 130% Overdriven w/ 6" Diameter Clutch

INSTALLATION NOTES (CONTINUED)

14. Install the clutch pump and main bracket (1) onto the engine with bolts (2) at mounting location [A] and bolts (3) at mounting location [B]. Torque bolts to 24-27 ft/lbs.
15. Install the power steering pump bracket (4) onto the main bracket (1) using bolts (5). Remove the suction hose elbow from the power steering pump. Install fitting (6) reusing the OEM bolt. Install hose (15) onto the power steering pump using clamp (16). Install the power steering pump reusing the OEM hardware. The steel high-pressure will need to be bent slightly for clearance, but does not need to be removed from the pump. The steel line usually works best when it is run behind the water pump pulley.
16. Install the alternator onto the main bracket (1) reusing the OEM hardware. Reconnect the wires.
17. Remove the grooved idler pulley from the OEM bracket. Install it onto the main bracket (1) just below the alternator with all OEM hardware.
18. Install the grooved idler pulley assembly (11-14) onto the new power steering pump bracket (4).
19. Install the tensioner bracket (7) with bolts (8) onto the main bracket (1). Install tensioner (9) with bolt (10).
20. First, install the OEM belt. Then, install the clutch pump belt (29). Route them as shown in the illustration.
21. Trim the fan ring as shown. Then, reinstall it back onto the engine. Rotating it counter-clockwise to get the rubber flap under the fan shroud works best (there will only be three mounting locations now). Use hardware (25-26) on the driver side of the fan ring mount to help avoid belt contact.
22. Reinstall the fan. Connect the fan wire. Attach the fan wire support back to its original location. Replace the top half of the fan shroud with OEM bolts.
23. Reinstall the power steering reservoir onto the fan shroud. Route the new return hose (15) to the reservoir. Cut the hose if necessary for the best fit. Secure it to the reservoir with clamp (16).
24. Properly refill any fluids that may have been drained. Check for leaks.
25. Reconnect the negative battery cables.

CAUTION: Before starting the engine, check to make certain no wires, hoses, etc. that may have been disturbed during installation do not come in contact with any hot or moving parts. Properly refill any fluids that may have been drained, check for leaks. Run the engine and check for proper belt tracking and clearance of any hoses, wires, etc. It is the installer's responsibility to correct/adjust any components, if necessary, before the vehicle is put into service.



Muncie® Power Products

CMKF23-67DA-P6-AC

2023 (Build Date: 01.01.2023 or Later)-2024 Ford F-250-F-550, F-600 Super Duty
6.7L V8 PowerStroke Diesel w/ A/C, w/ OEM Dual Alternators,
w/o Ford ProPower Option, w/o Adaptive Steering

Requires 6-Groove Clutch, Muncie PH Series Pad-Mount Pump
NOTE: Must Use Rear Ported Pump
Approximately 130% Overdriven w/ 6" Diameter Clutch

Parts List

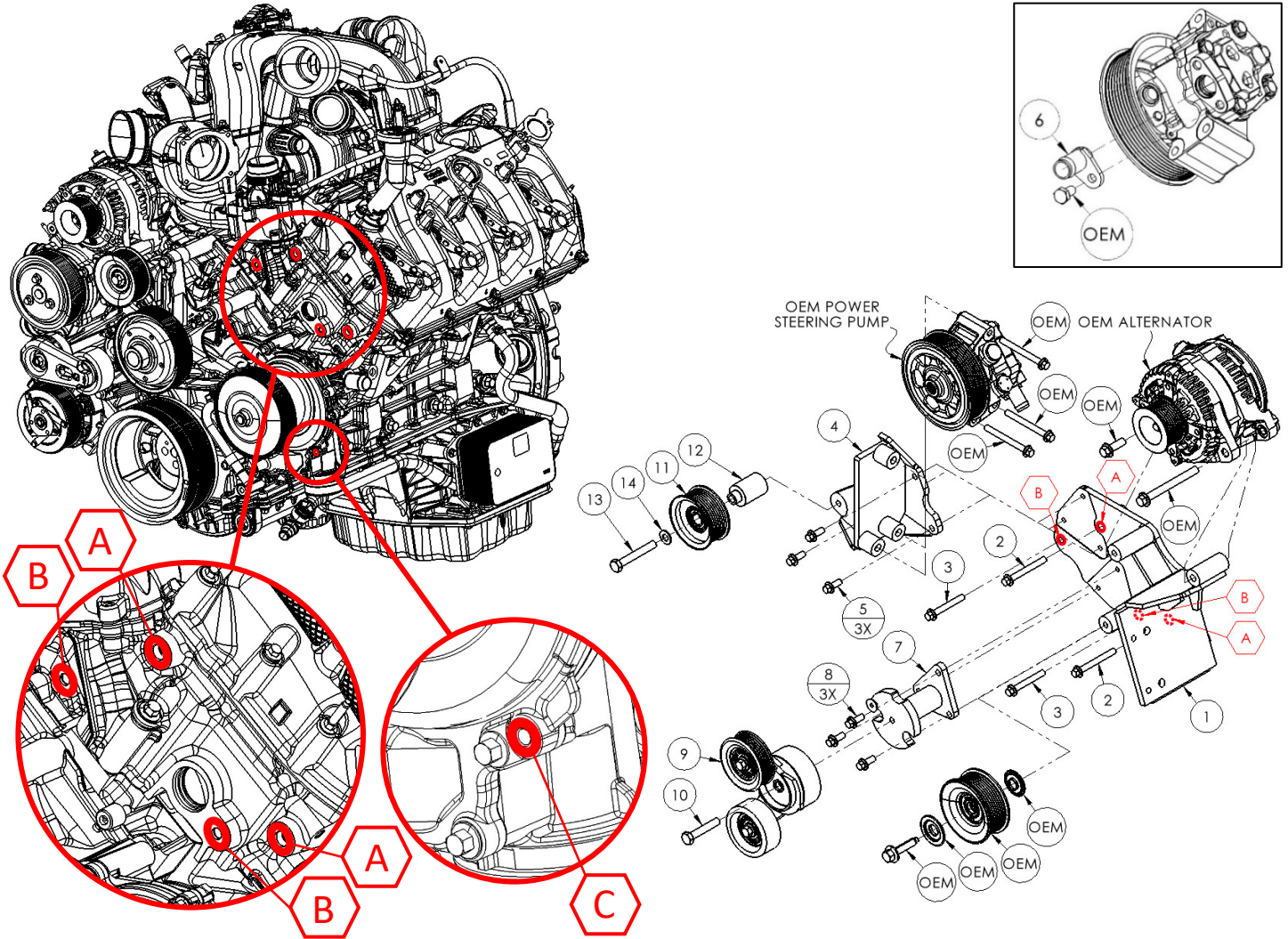

PARTS LIST							
Item	Part Number	Description	Qty.	Item	Part Number	Description	Qty.
Main Bracket				Tensioner Assembly			
1	FMP2671-I6	Main Bracket	1	9	89254-007-051M	Custom Assembled & Modified Tensioner	1
Main Bracket Mounting Hardware				Grooved Idler Pulley Assembly			
2	1018206	M8-1.25 x 70mm 10.9Gr Hex Flg. Bolt	2	10	1006925	M10-1.5 x 55mm 10.9Gr Hex Bolt	1
3	1018001	M8-1.25 x 60mm 10.9Gr Hex Flg. Bolt	2	11	89053	Dayco 8-Groove Idler Pulley	1
Power Steering Pump Bracket Assembly				12	FMB2654	Machined Idler Bushing	1
4	FMB2651	Power Steering Pump Bracket	1	13	1011649	M10-1.5 x 70mm 10.9Gr Hex Bolt	1
5	1013329	M8-1.25 x 20mm 10.9Gr Hex Flg. Bolt	3	14	1002596	3/8" Flat Washer	1
Power Steering Pump Fitting							
6	FMB2657	Power Steering Pump Fitting	1				
Tensioner Bracket Assembly							
7	FMB2672	Tensioner Bracket	1				
8	1013329	M8-1.25 x 20mm 10.9Gr Hex Flg. Bolt	3				



**Muncie®
Power
Products**

CMKF23-67DA-P6-AC

2023 (Build Date: 01.01.2023 or Later)-2024 Ford F-250-F-550, F-600 Super Duty
6.7L V8 PowerStroke Diesel w/ A/C, w/ OEM Dual Alternators,
w/o Ford ProPower Option, w/o Adaptive Steering

Requires 6-Groove Clutch, Muncie PH Series Pad-Mount Pump
NOTE: Must Use Rear Ported Pump
Approximately 130% Overdriven w/ 6" Diameter Clutch

Parts List



Battery Cable Support Hardware (17-21)

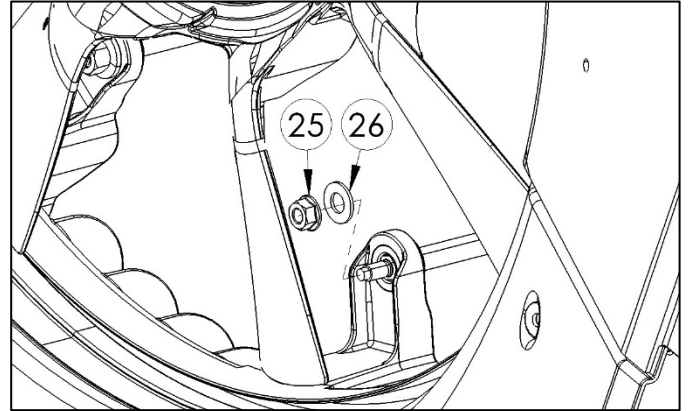

Fan Shroud Mounting Hardware (25-26)

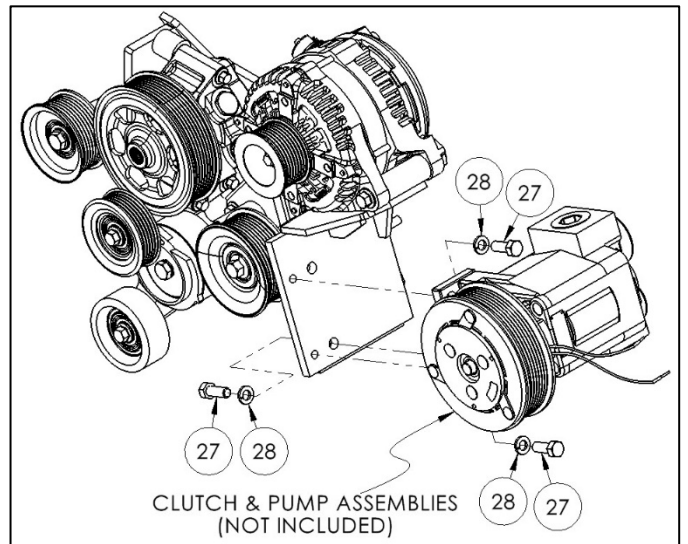

Clutch Pump Mounting Hardware (27-28)

PARTS LIST							
Item	Part Number	Description	Qty.	Item	Part Number	Description	Qty.
Power Steering Pump Suction Line Hardware (Not Shown)				Fan Shroud Mounting Hardware			
15	1011671	3/4" Oil Hose	40"	25	1013333	M8-1.25 10.9Gr Flg. Nut	1
16	1011673	#12 Hose Clamps	2	26	1002596	3/8" Flat Washer	1
Battery Cable Support Hardware				Clutch Pump Mounting Hardware			
17	1005110	#16 Adel Clamp	1	27	1005274	3/8"-16 x 1" NC Gr5 Hex Bolt	3
18	1016330	M6-1.0 x 20mm 10.9Gr Hex Flg. Bolt	1	28	1010315	3/8" Lock Washer	3
19	1018238	3/4" Protective Plastic Hose	20"				
20	1007564	1" Heater Hose	6"				
21	1005413	7-1/2" Zip Ties	4				
Coolant Reservoir Hose (Not Shown)							
22	F265HH	Custom Rubber Hose	1				
23	1011672	#16 Hose Clamp	1				
24	1009294	#20 Hose Clamp	1				



Belt Routings

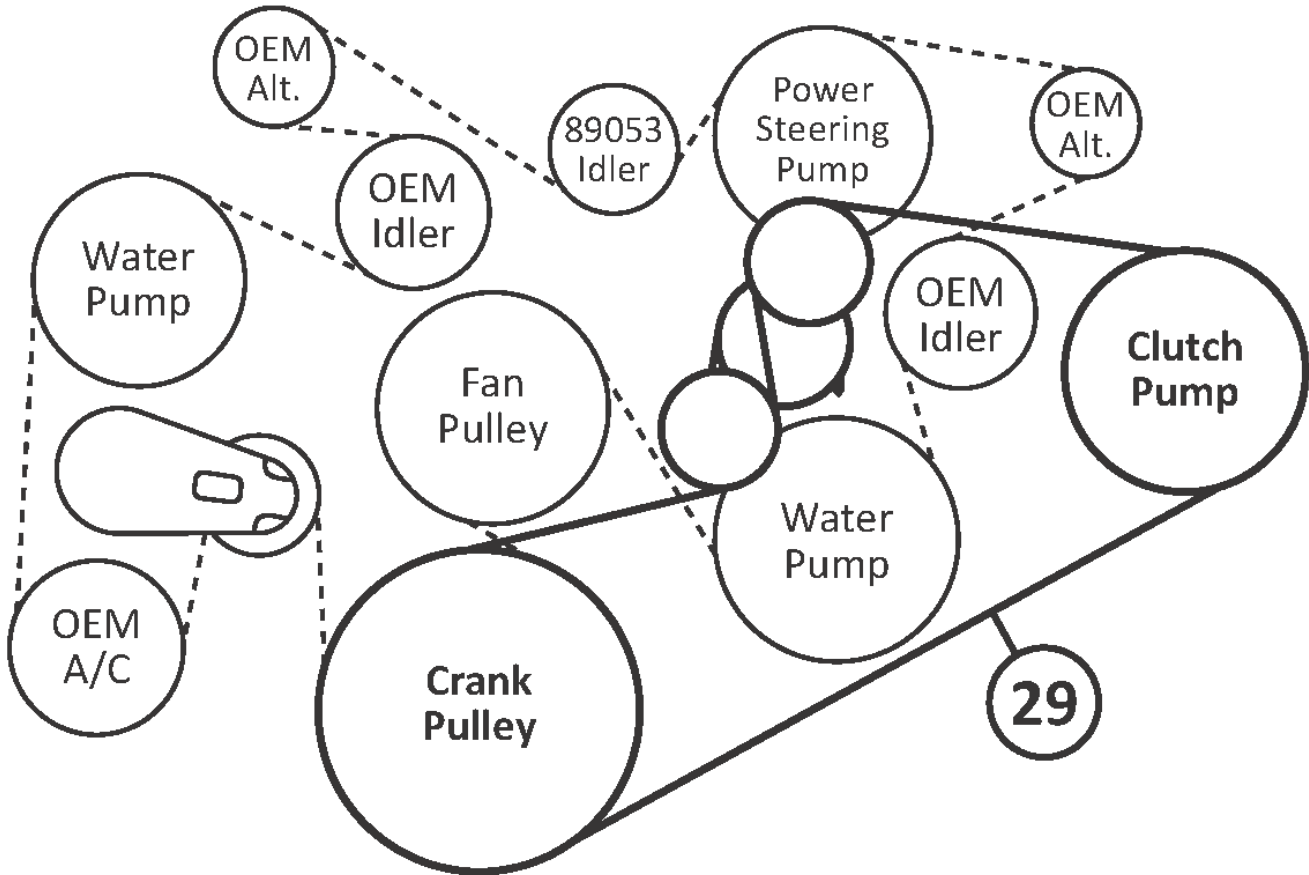

PARTS LIST			
Item	Part Number	Description	Qty.
Belt (Only One is Supplied)			
29	1060665	Goodyear 6-Groove, 66.5" Belt	1
	5060665	Dayco 6-Groove, 66.5" Belt	1
	6PK1690	Metric 6-Groove, 1690mm Belt	1



**Muncie®
Power
Products**

CMKF23-67DA-P6-AC

2023 (Build Date: 01.01.2023 or Later)-2024 Ford F-250-F-550, F-600 Super Duty
6.7L V8 PowerStroke Diesel w/ A/C, w/ OEM Dual Alternators,
w/o Ford ProPower Option, w/o Adaptive Steering

Requires 6-Groove Clutch, Muncie PH Series Pad-Mount Pump
NOTE: Must Use Rear Ported Pump
Approximately 130% Overdriven w/ 6" Diameter Clutch



**Fan Ring Modification
(Remove Highlighted Areas)**



Step 12 Guidance Photo

