



Muncie[®]
Power
Products

CMKF83-6910-A-AC
1983-92 Ford Truck 250,350
6.9,7.3 Diesel W-WO/AC
(Non-Serpentine)

INSTALLATION NOTES

1. Disconnect positive battery terminal.
2. Remove fan, shroud and belts. On 7.3 engines remove formed ram air tube between corrugated tube and radiator support. On 1988 and later models there may be interference between the air duct tube and clutch pump. Duct tube is normally discarded, modification by installer to adapt tube is required to retain.
3. Remove and discard bolts and 5" O.D. steel brace from pulley on front of crankshaft. Install drive pulley (1) with provided bolts (2) and washers (3). **CAUTION:** Be sure new bolts have the same threads as the O.E. M. bolts removed.
4. Cut 5/8" off power steering pump bracket as shown in diagram. Remove bolts at locations "C & D".
5. Install mounting bracket (6) and power steering pump spacers (16,17,18) and bolts (9,12 & 13). NOTE: Install bolt (9) first, but do not tighten. Secure bolts at locations "C,D & E". NOTE: Some older trucks require longer spacers and bolts at locations "C & D", use bolts and spacers provided with instructions at these locations.
6. Install fan spacer nut (4). Install fan and shroud. Tighten fan and spacer nut to 163 ft/lb. (left hand thread). NOTE: A mild grade of Loctite type sealant on threads may be advisable. Install turnbuckles (5) to hold standard radiator in place or slightly ahead.
7. Install and tighten all belts and bolts.
8. Install pump plate (8) and pump (23) with provided bolts (11,14,15). Make sure clutch pulley is in line with drive pulley, tighten pump bolts provided. Install and align flat idler (IPKD-45) if being used.
9. Install pump drive belts (22). Adjust pump plate (8) for proper belt tension. Tighten bolts (11,14 & 15) on pump plate. Connect battery terminal.
10. **CAUTION:** Check all engine compartment vacuum hoses and electrical wiring that might have been disturbed or re-routed during kit installation to be sure that hoses are not kinked, that they do not touch any high temperature item, and that they do not interfere with any linkage components.

NOTE: Power steering line and ram air tube may need to be re-routed. Fan shroud may need notched for belt clearance. This kit is designed to operate successfully with the standard fan supplied by the manufacturer of your truck. Due to O.E.M. assembly tolerances, visually make certain that there is adequate clearance between fan and drive pulley, and also between fan and radiator. It may be necessary to use a longer spacer for pulley clearance. If there is little clearance to the radiator, check with Ford dealership to insure that it will not flex into the radiator before operating. It is not uncommon for radiator to flex toward fan while driving at highway speed or through rough terrain. Provide adequate clearance before operating, move radiator forward if necessary. Turnbuckles provided usually keep standard radiator from being blown into fan but cannot keep truck from flexing. Super cooling radiator is secured better and normally will not blow into fan.

Tighten belts to eliminate excessive belt whip.

CMKF83-6910-A-AC
 1983-92 Ford 6.9,7.3 Diesel
 W-WO/AC (Non-Serpentine)

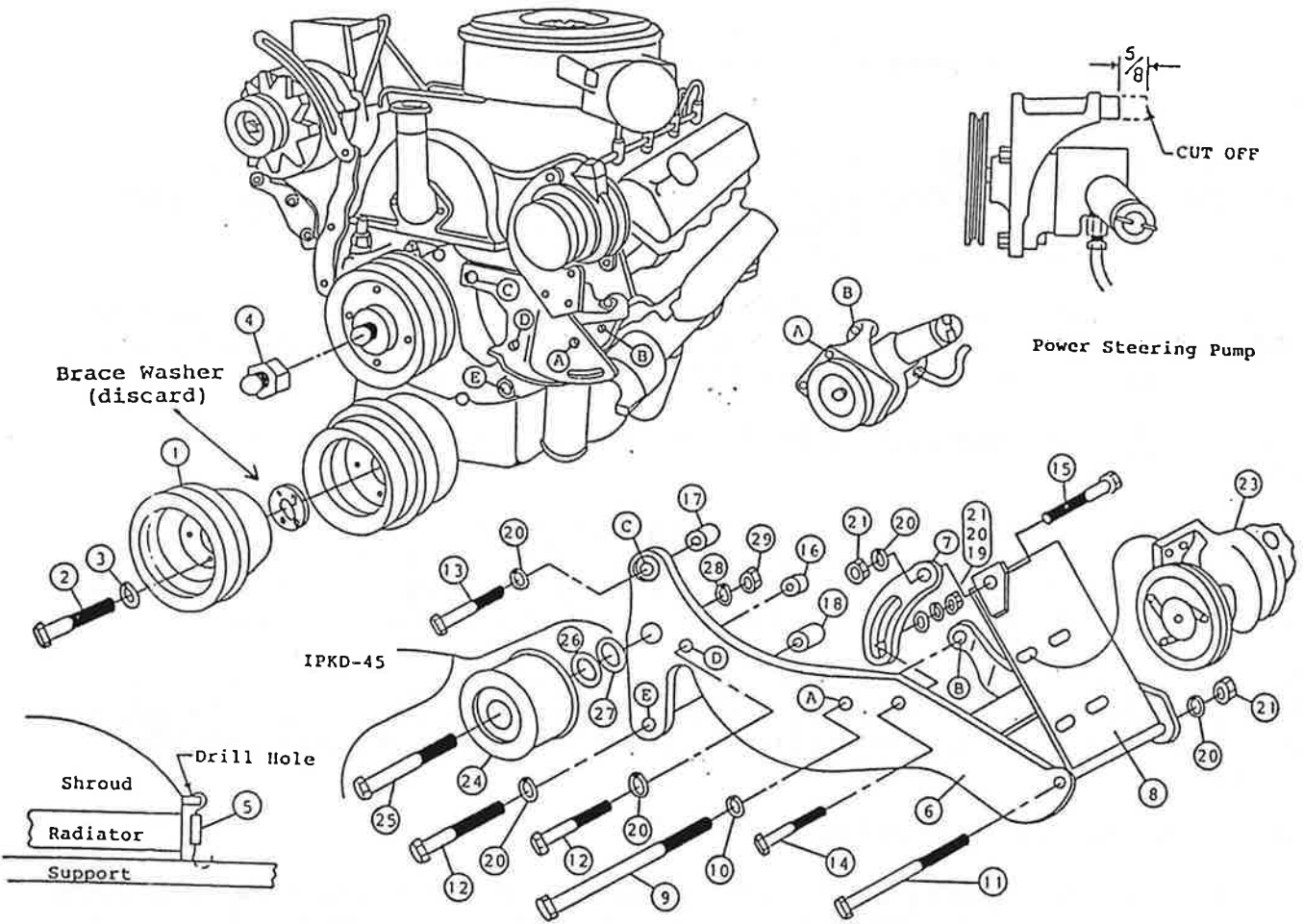

PARTS LIST

- | | |
|-----------------------------|------------------------------|
| 1. FPC 612 (1) | 13. 3/8 X 1-3/4 NC (1) |
| 2. 3/8 X 1-3/4 NC GR. 8 (4) | 14. 3/8 X 1-1/2 NC (1) |
| 3. 3/8 LW (4) | 15. 3/8 X 1-1/4 NC (1) |
| 4. FSK 7.3 (1) | 16. SP64-0.500 (1) |
| 5. Turnbuckles (2) | 17. SP88-0.500 (1) |
| 6. FMB 610 (1) | 18. SP88-0.7500 (1) |
| 7. FMB 611 (1) | 19. 3/8 FW (1) |
| 8. FMP 611 (1) | 20. 3/8 LW (6) |
| 9. 7/16 X 6-1/2 NC (1) | 21. 3/8 NC (3) |
| 10. 7/16 LW (1) | 22. 2A66 (1) (Not Shown) |
| 11. 3/8 X 4-1/2 NC (1) | 23. Clutch Pump Assembly (1) |
| 12. 3/8 X 2 NC | (Sold Separately) |
- IDLER ASSEMBLY (IPKD-45)**
- | | |
|------------------------|-----------------|
| 24. IPCD (1) | 27. 5/8 FW (15) |
| 25. IPW14 (5) | 28. 5/8 LW (1) |
| 26. 5/8 X 4-1/2 NC (1) | 29. 5/8 NC (1) |