



Muncie[®]
Power
Products

CMKF93-830L-A
CMKF93-830L-AH

1993-98 Ford L-8000

8.3 Cummins (1460)

WO/AC

INSTALLATION NOTES

1. Disconnect battery and loosen serpentine belt.

FOR TRUCKS WITH AIR CLUTCH COOLING FAN: Remove the upper radiator support bracket from the radiator and move the top of the radiator ahead. Disconnect air hose at the fan. Remove the entire fan and pulley assembly from the truck by removing the four bolts going into the front of the block. Assembly must be removed from the right hand side of the truck. Dissassemble and install drive pulley between clutch spacer and fan pulley. Re-assemble and install.

FOR TRUCKS WITHOUT AIR CLUTCH COOLING FAN: Remove the fan and install the drive pulley between the fan and fan pulley.

NOTE: Be sure pulley bolts (2) provide adequate thread engagement.

2. Install bracket (3) with bolts (10) at locations "A-D", secure bracket. Install pump plate (4) to bracket (3), leave bolts loose.
3. Install clutch pump (13) to pump plate (4) with pump mounting bolts provided. Align clutch pulley to drive pulley (1), secure pump bolts.
4. Install serpentine belt. Install clutch pump belts and tighten, reconnect battery. It may be necessary to support upper radiator line away from clutch pump, or lengthen rubber hose at engine to raise radiator line.

NOTE: This kit is designed to operate successfully with the standard fan supplied by the manufacturer of your truck. Due to O.E.M. assembly tolerances and change, visually make certain that there is adequate clearance between fan and drive pulley. It may be necessary to use a different spacer for proper clearance.

CMKF93-830L-A
CMKF93-830L-AH

1993-98 Ford (1460) 8.3 Cummins
 L-8000, WO/AC

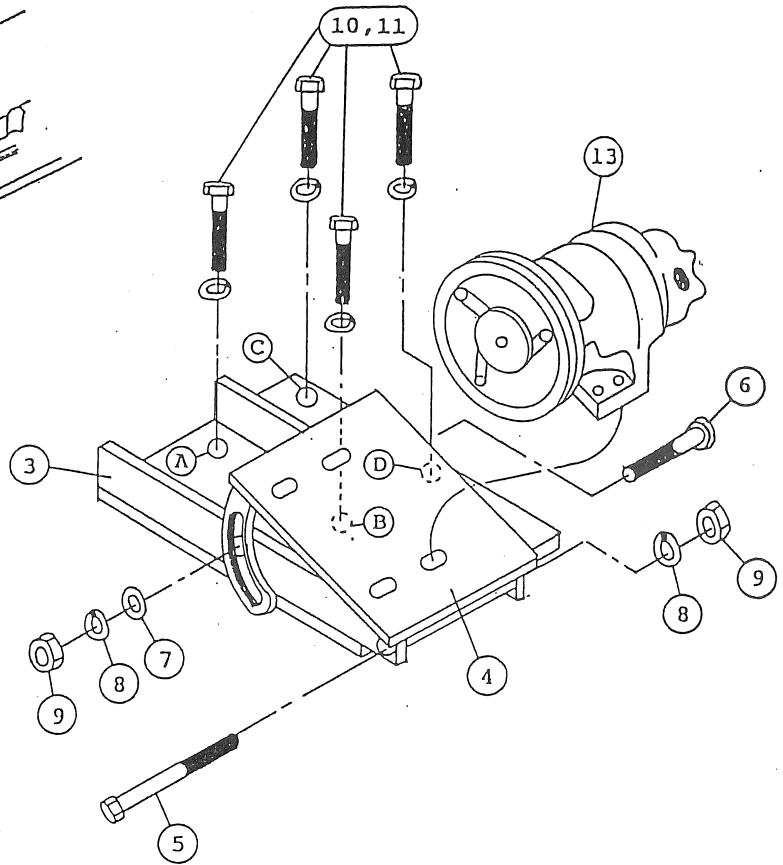
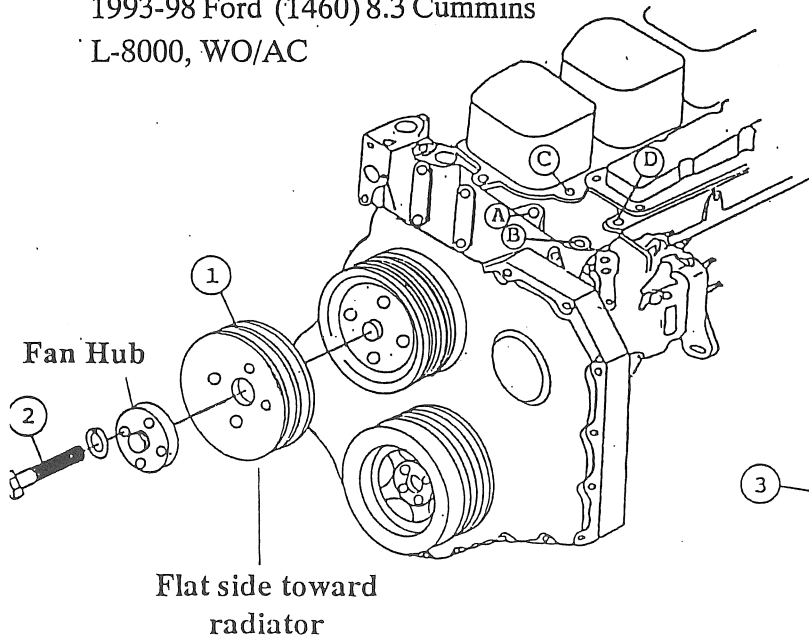

PARTS LIST

- | | |
|-----------------------------|---------------------------|
| 1. FPC 812 (1) | 8. 3/8 LW (2) |
| 2. 10mm X 30mm 1.5 SHCS (4) | 9. 3/8 NC (2) |
| 3. FMB 810 (1) | 10. 10mm X 30mm 1.5 (4) |
| 4. FMP 811 (1) | 11. 10mm LW |
| 5. 3/8 X 5 1/2 NC (1) | 12. AX-41 (2) (Not Shown) |
| 6. 3/8 X 1 1/2 NC (1) | H.D.: AX-43 |
| 7. 3/8 FW (1) | 13. Clutch Pump Assembly |
| | (Sold Separately) |