



**Muncie[®]
Power
Products**

**CMKI87-3900-A
CMKI87-3900-AH**

**1987-96 ISUZU
NPR390, GMC W-4
3.9 WO/AC**

INSTALLATION NOTES

1. Disconnect battery terminals. Mark location of fan clutch to adapter plate and adapter plate to water pump pulley for proper re-assembly later. Remove clutch and fan from adapter plate, lay assembly in shroud. Loosen bolts holding adapter plate to water pump. Remove alternator belts and alternator
87 MODELS - Remove and discard two factory brackets as shown.
88 MODELS - Remove and discard radiator shroud support bracket. Remove large alternator/AC bracket, cut bracket as shown. Replace top section for alternator mount, discard lower section. Install bracket (11) to support radiator shroud.
2. Remove single groove AC pulley from crankshaft. Install drive pulley (1) with proper diameter bolts supplied.
CAUTION: Be sure bolts are same thread as O.E.M. bolts removed and pulley is properly piloted to O.E.M. pulley.
3. Remove adapter plate and water pump pulley. Remove bolts at locations "A & B" and install bracket (9) with bolts (15) and spacers (13). Install alternator with original hinge bolt at location "C". Secure bolts (15). Install water pump pulley and adapter, exactly as removed.
4. Install pump plate (12) with bolts (16 & 17) and spacers (13). With hose fittings installed on clutch pump, hold pump in mounting location and check clearance between lower fitting and top of motor mount. It may be necessary to modify top of motor mount for clearance.
NOTE: With #2 plate install rear pump bolts and washers before bolting bracket to engine.
5. Mount clutch pump with bolts provided. Use straight edge to align clutch to drive pulley (1), tighten pump bolts. Install idler pulley (28) to bracket (9), use straight edge on drive pulley (1) to determine proper spacers required.
NOTE: Snap ring on idler is front (radiator) side.
6. Install fan clutch to adapter in same location as marked from step 1. If fan spacers (6) are required, remove fan from clutch, install spacers as shown and secure with bolts (7).
CAUTION: Be sure fan and spacers are properly piloting onto clutch.
7. Install and tension alternator belts. It will probably be necessary to remove idler to install pump drive belts (32). Snug bolt (29) to hold idler in place, yet still allow adjustment. Tighten lower nut (22) to raise idler until belts are properly tensioned. Tighten bolt (29) and upper nut (22). Connect battery terminals.

CAUTION: Check all engine compartment vacuum hoses and electrical wiring that may have been disturbed or re-routed during kit installation to be sure that hoses are not kinked, that they do not touch any high temperature item, and that they do not interfere with any linkage components. Be sure clutch will not contact wiring in framerail.

NOTE: This kit is designed to operate successfully with the standard fan supplied by the manufacturer of your truck. Due to O.E.M. assembly tolerances, visually make certain that there is adequate clearance between fan and drive pulley, and also between fan to radiator. It may be necessary to use a longer spacer for pulley clearance. If there is little clearance to the radiator, check to insure that it will not flex into the radiator before operating. It is not uncommon for fan to flex under full acceleration. Move radiator forward if necessary.

CMKI87-3900-A
CMKI87-3900-AH

1987-96 ISUZU NPR390; GMC W-4
 3.9 WO/AC

87 Models

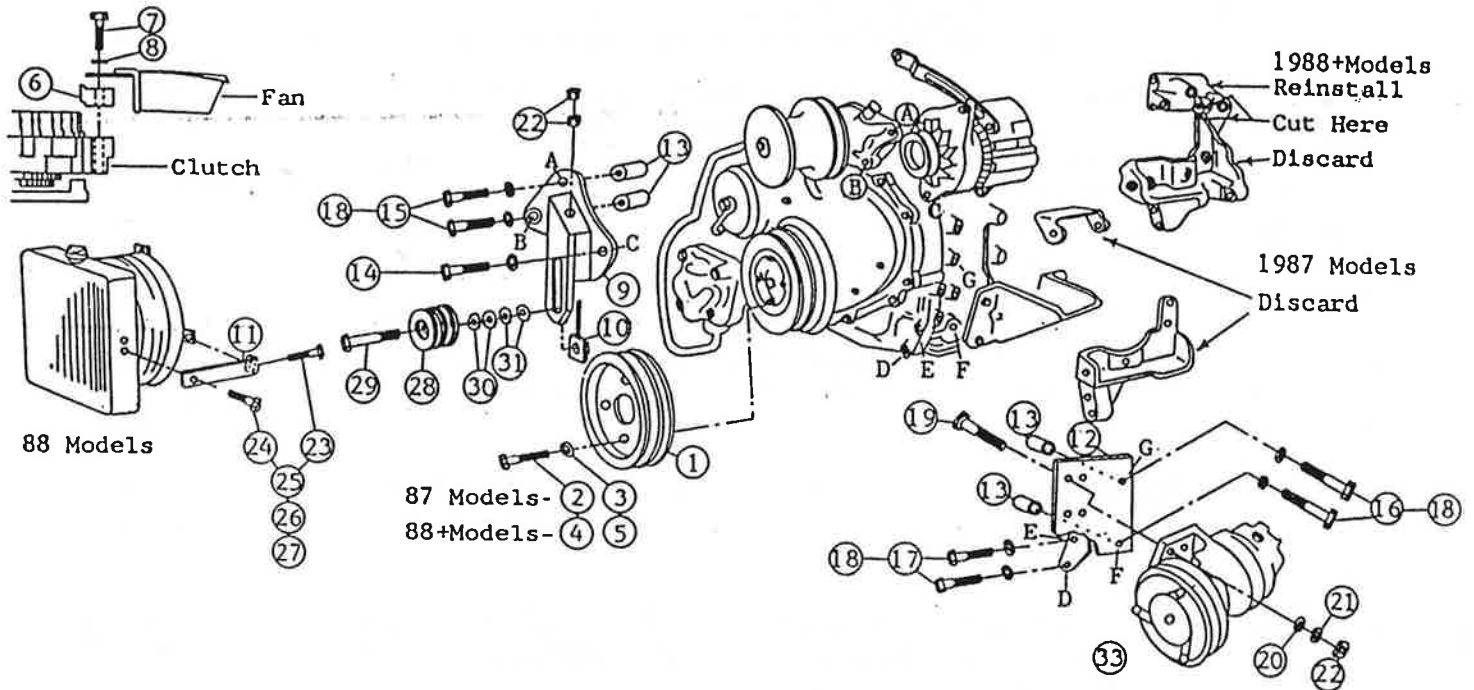

PARTS LIST

- | | |
|--------------------------|--------------------------------------|
| 1. SPC 312 (1) | 18. 10mm LW (6) |
| 2. 7mm x 35mm 1.25 (4) | 19. 3/8 X 1 1/2 NC (4) |
| 3. 7mm LW (4) | 20. 3/8 FW (4) |
| 4. 8mm X 30mm 1.25 (4) | 21. 3/8 LW (4) |
| 5. 8mm LW (4) | 22. 3/8 NC (6) |
| 6. FSO 3.9 (4) | 23. 5/16 x 1 1/2 NC (1) |
| 7. 6mm X 45mm 1.00 (4) | 24. 5/16 x 3/4 NC (1) |
| 8. 6mm LW (4) | 25. 5/16 FW (2) |
| 9. SMB 310 (1) | 26. 5/16 LW (2) |
| 10. SMB 311 (1) | 27. 5/16 NC (2) |
| 11. SMB 312 (1) | 28. GPCD (1) |
| 12. SMP 311 (1) | 29. 5/8 X 3 NC (1) |
| 13. SP88-0.750 (4) | 30. IPW 14 (5) |
| 14. O.E.M. Bolt | 31. 5/8 FW (2) |
| 15. 10mm x 80mm 1.25 (2) | 32. 9450 (2), H.D.: 9470 (Not Shown) |
| 16. 10mm X 65mm 1.25 (2) | 33. Clutch Pump Assembly (1) |
| 17. 10mm x 30mm 1.25 (2) | |

(Sold Separately)