



**Muncie[®]
Power
Products**

**CMKI96-5700-A-AC
CMKI96-5700-AH-AC**

**1996-00 ISUZU
NPR EFI & W4 GAS
350, W-WO/AC
(Serpentine)**

INSTALLATION NOTES

1. Disconnect battery ground cable. Drain anti-freeze approximately 5 inches. Remove upper radiator hose at the radiator, loosen serpentine belt. Remove fan and fan shroud. The fan is removed by loosening the large nut in a right hand direction. Remove the bolts holding the crank pulley on and install the drive pulley inside the OEM pulley with the bolts provided.
2. Remove the three bolts at locations A,B & C and the lower alternator bolt. Remove serpentine idler pulley. Position 5/8 slide nut (27) into the slot in bracket (8) from the back side. Install the front main bracket in holes A,B & C using bolts (15) and lockwasher (22). Bushing (7) goes behind bracket (8) at hole A. Install bolt (16) through hole D of bracket (8) and the lower alternator hole. Do NOT tighten bolts. Position pump plate on the main bracket and slide bolt (14) through from the front side. Install short brace (11) on the back of the lower alternator bolt, and the back of the plate. Remove the front bolt from the exhaust manifold and install the brace (12) from the manifold to the back of the plate using bolt (17) at the manifold. Install lockwashers and nuts at the back of alternator and plate, Do NOT tighten. Remove the two bolts at locations G & H, install the pump plate slide bracket (10) over top of the shroud brace using bolts (20) and lockwashers (22). Install adjustment slide (9) with bolts (18 & 19) nuts (23) and lockwashers (22) with the slot towards the pump plate. Tighten bolts at all locations except pump plate bolts.
3. Install fan spacer nut (6), fan and fan shroud. Install serpentine idler pulley and serpentine belt. Connect radiator hose and fill radiator.
4. Mount the clutch pump on the pump plate and align it with the drive pulley. Install idler kit and align it with pump and drive pulley by adding or subtracting spacers. Install v-belts. When tightening pump drive belts, use idler to take up all slack in the belts, then tighten the rest of the way with the plate. Tighten mounting plate bolts.

CAUTION: If heater lines are in the way, use a pry bar at the two standoff locations and pry them out next towards the shock tower.

Connect battery cable. Check for proper clearance of belts, wire or hoses.

CMKI96-5700-A-AC
CMKI96-5700-AH-AC

1996-00 Isuzu
 NPR EFI & W4 GAS
 350 W-WO/AC
 (Serpentine)

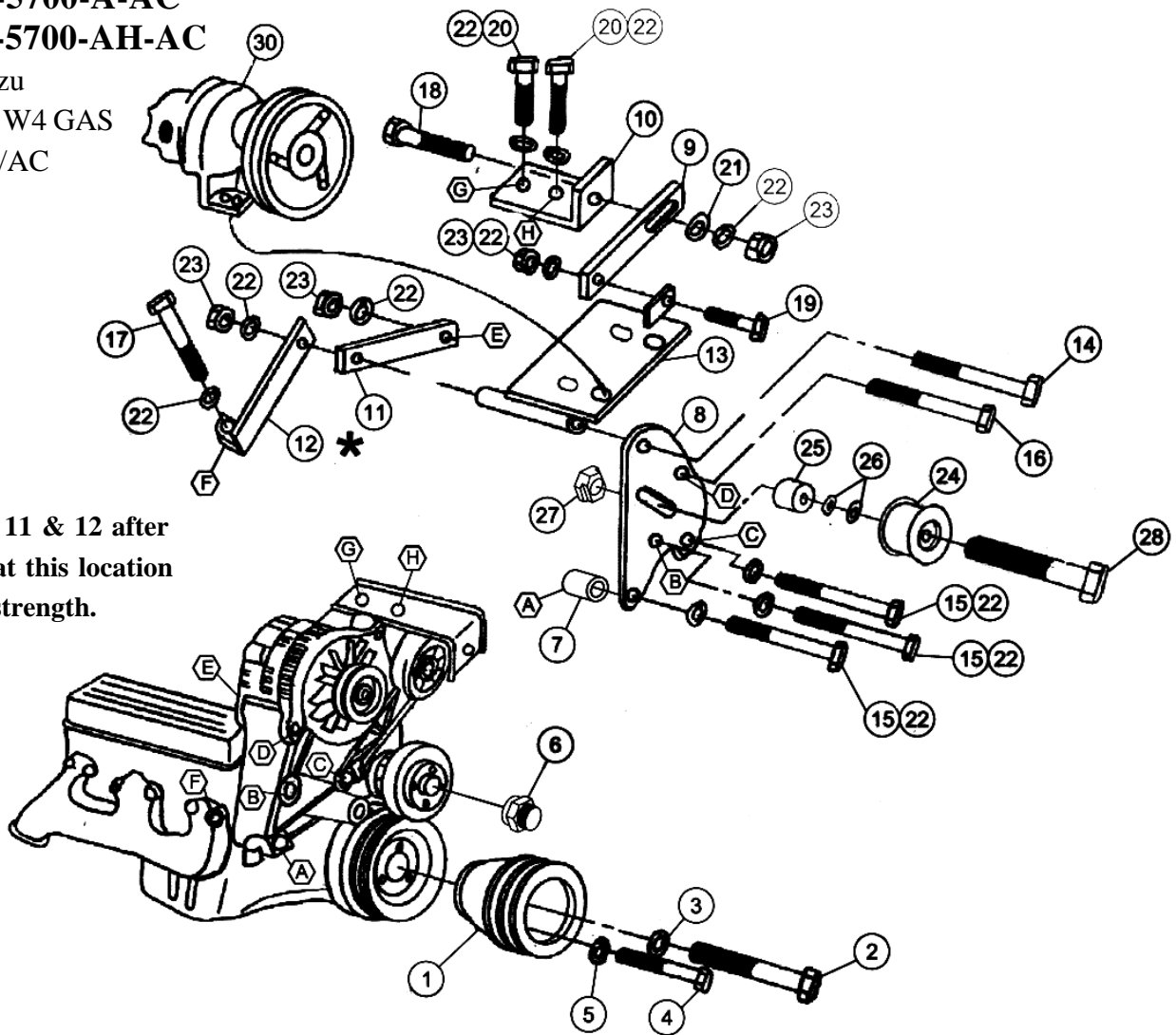

*Weld bars 11 & 12 after assembly at this location for extra strength.

PARTS LIST

- | | |
|------------------------------|--|
| 1. SPC 362 (1) | 16. 3/8 x 5 1/2 NC (1) |
| 2. 7/16 x 3 NF Gr. 8 (1) | 17. 3/8 x 2 1/2 NC (1) |
| 3. 7/16 LW (1) | 18. 3/8 x 1 1/2 NC (1) |
| 4. 3/8 x 1 1/2 NF Gr. 8 (3) | 19. 3/8 x 1 1/4 NC (1) |
| 5. 3/8 LW (3) | 20. 3/8 x 1 NC (2) |
| 6. FSK37R (1) | 21. 3/8 FW (1) |
| 7. SP88-4.0625 (1) | 22. 3/8 LW (10) |
| 8. SMB 360 (1) | 23. 3/8 NC (4) |
| 9. SMB 351 (1) | 24. IPCD (1) |
| 10. SMB 352 (1) | 25. SP175-1.250 (1) |
| 11. SMB 353 (1) | 26. IPW 14 (7) |
| 12. SMB 354 (1) | 27. 5/8 NC (W/ Sides Milled) (1) |
| 13. SMP 351 (1) | 28. 5/8 x 3 1/2 NC (1) |
| 14. 3/8 x 6 NC (1) | 29. AX-64 (2), H.D.: AX-66 (Not Shown) |
| 15. 3/8 x 5 3/4 NC Gr. 8 (3) | 30. Clutch Pump Assembly (1) |
| | (Sold Separately) |