



**Muncie[®]
Power
Products**

CMKM04-3126-P8-AC

2004-2009 Sterling Acctera

3126, C7 CAT Diesel

W/AC, W-W/O Air Brakes

INSTALLATION NOTES

1. Remove the eight bolts holding the damper onto the crankshaft. Install pulley (1) between the damper and the O.E.M. pulley using bolts (3) and lockwashers (2). Torque bolts to 40 ft.lbs..
2. Install pump bracket (4) with bolts (5) and lockwashers (2) onto the engine as shown in the illustration. If vehicle is equipped with air brakes, fitting (12) must be used to reroute the pop-off valve for hose clearance.
3. Install the pump (8) onto plate (9) with bolts (10,11), lockwashers (12), and nuts (13). Torque to 30ft. lbs. Install the pump and plate assembly onto bracket (4) with bolts (15), lockwashers (12), and flatwashers (14). Align the clutch pump with the drive pulley then torque bolts (15) to 30 ft. lbs. Install tensioner (6) with bolt (7). Install the pump belt as shown in the illustration. Check for proper belt tensioning and clearances to any hot or moving parts. Run the engine and check for proper belt tracking. Adjust if necessary.

NOTE: Will not work on engines with the fuel filter at the 1:00 position unless installer recloates the fuel filter.

CMKM04-3126-P8-AC

2004-2009 Sterling Acctera

3126, C7 CAT Diesel

W/AC

W-W/O Air Brakes

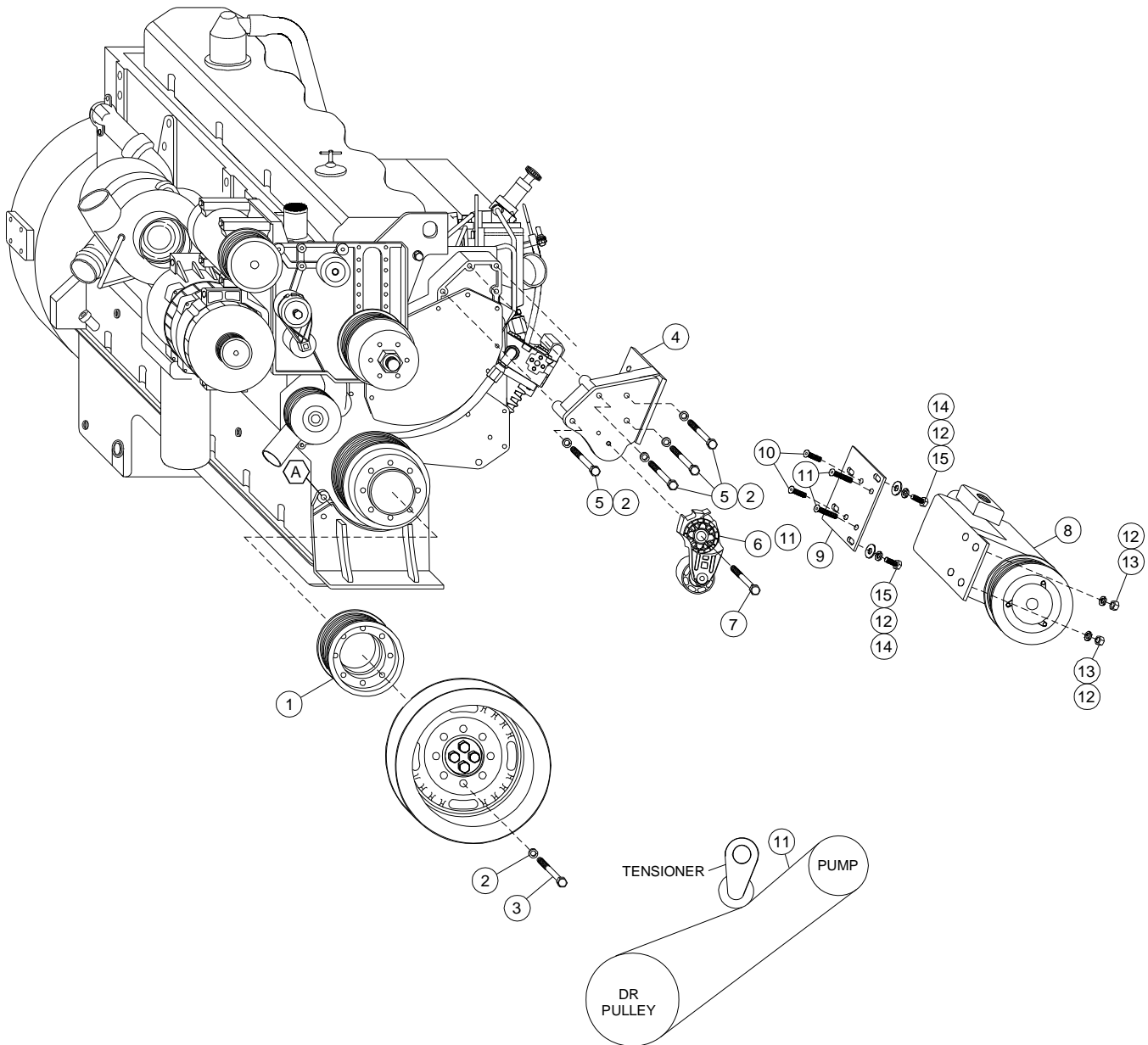

PARTSLIST

1. FPC 938 (1)
2. 10mm LW (15)
3. 10mm x 65mm (8)
4. FLMB 901 (1)
5. 10mm x 80mm (4)
6. Tensioner 89200B (1)
7. 10mm x 75mm (1)
8. Clutch pump (Sold Separately)
9. IMP 634 (use w/#4 only)

BELT DIAGRAM

10. 3/8-16 x 1 FHSCS (2)
11. 3/8-16 x 1-1/2 FHSCS (2)
12. 3/8 LW (6)
13. 3/8-16 Nut (2)
14. 3/8 FW (4)
15. 3/8-16 x 1 Bolt (4)
16. 5080630 Dayco
17. 5500-8 Elbow Thompkins (not shown)