



**Muncie®  
Power  
Products**

**CMKM04-9002-YP8  
2000-05 Sterling Acctera  
906 & 926 Mercedes-Benz 6 cyl.  
W/O AC, W-W/O Air Brakes**

## **INSTALLATION NOTES**

---

1. Disconnect the negative battery cable(s). Remove the engine accessory drive belt and the alternator. Using a jack or other suitable tool, support the front of the engine; then remove the lower alternator bracket/motor mount and the upper alternator brace from the engine. Remove the two alignment bushings from the motor mount and install them into the new pump bracket at hole locations A and B.
2. Install the pump bracket (1) onto the engine at the same location that the alternator bracket was using; Re-use the O.E.M. bolts. Torque the 12mm bolts to 75-80 ft. lbs., and the 14mm bolts to 115-125 ft. lbs. Install bushing (2) between the engine and the bracket at location (F) and secure it with bolt (3), lock washer (4), and flat washer (5). Torque bolt (3) to 35-40 ft. lbs.
3. Install the clutch pump onto the bracket with bolts (12), lock washers (13), and nuts (14). Torque nuts to 35 ft. lbs. Install bracket (6) onto the engine with bolt (7) lock washer (4) at location (C). **DO NOT TIGHTEN.** Install the alternator with the O.E.M. bolts. Torque bolt (7) to 35-40 ft. lbs. and the alternator bolts to 40-45 ft. lbs. Install the coil adapter plate (18) with bolts (19). Torque to 8-10 ft. lbs. Install the coil and clutch as per manufacture's instructions. Install idler (8) with bushing (9), flatwasher (11), and bolt (10) at location (E). Torque bolt (10) to 40 ft. lbs.
4. Remove the O.E.M. belt tensioner and replace it with the new tensioner (15); Re-use the O.E.M bolt. Torque bolt to 30-35 ft. lbs. Install the drive belt (16) and route it according to the belt diagram. Connect the battery cable(s). Run the engine to check for proper belt tracking.

Note: Make certain any hoses, wires etc., that were disturbed during installation are not against any hot or moving parts.

# CMKM04-9002-YP8

2000-05 Sterling Acctera  
 906 & 926 Mercedes-Benz 6 cyl.  
 W/O AC, W-W/O Air Brakes

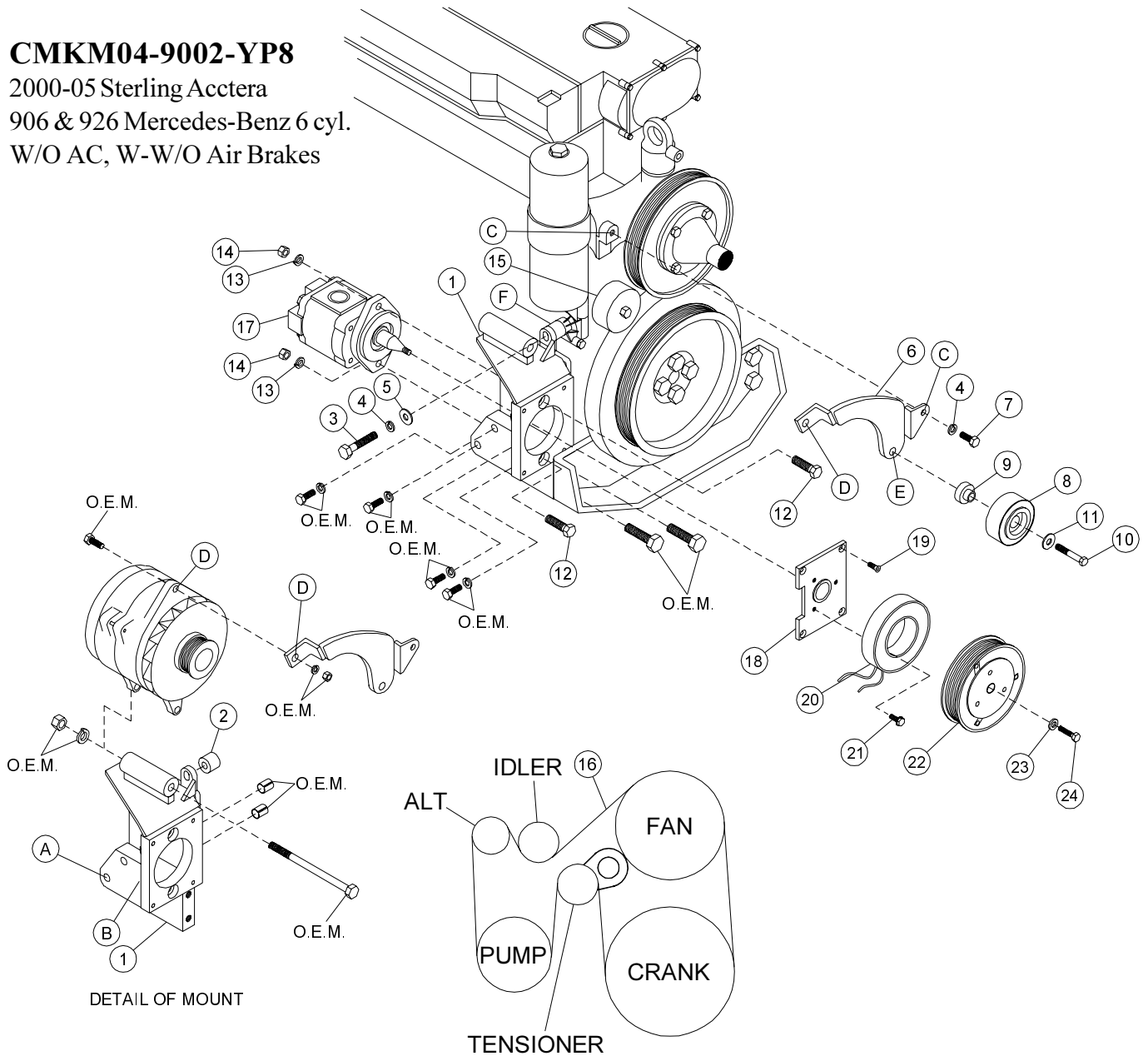

## BELT ROUTING

### PARTSLIST

- |                               |   |
|-------------------------------|---|
| 1. STMP 61A (1)               | 13. 3/8 x LW (2)                              |
| 2. SP100-.813 (1)             | 14. 3/8-16 nut (2)                            |
| 3. 10mm x 45mm x 1.5 bolt (1) | 15. Tensioner A906 200 2470 Mercedes Benz     |
| 4. 10-mm LW (2)               | 16. 5080805 Dayco Belt (1)                    |
| 5. 10mm FW (1)                | 17. Clutch Pump (sold separately)             |
| 6. STMB 611 (1)               | 18. MCA01 Clutch Mtg. Plate (1)               |
| 7. 10mm x 25mm x 1.5 bolt (1) | 19. 1/4 x 3/4 NC FHSCS (4)                    |
| 8. TIPCS Idler (1)            | 20. Coil (sold separately) (1)                |
| 9. STMB 612 (1)               | 21. Cap Screw - 19T34530 (3) (T=8-10ft./lbs.) |
| 10. 12mm x 40mm bolt (1)      | 22. Clutch (sold separately) (1)              |
| 11. 12mm FW (1)               | 23. Flat Washer - 21MZ3487 (1)                |
| 12. 3/8-16 x 1-1/2 bolt (2)   | 24. Cap Screw - 19T38756 (1) (T=20ft./lbs.)   |