



Muncie<sup>®</sup>  
Power  
Products

CMKN89-4600-A-AB  
CMKN89-4600-AH-AB

1989-93 International  
DTA360 & 466, WO/AC  
W/AIR BRAKES ONLY

## INSTALLATION NOTES

---

1. Disconnect battery. Remove belt on air compressor and bolt at locations "C & D" on water pump.
2. Mark location of fan hub to inside pulley for proper re-installation. Remove fan and outside pulley, replace pulley with drive pulley (1) using O.E.M. bolts. Re-install fan aligning marks. Secure fan.
3. Install pump plate (3) and tension bracket (4) at locations "A -D" using bolts (6 & 11). Secure bolt (11). Install slotted strap (5) at location "E" and to pump plate (3) using bolts (7 & 12). Leave bolts (6,7, & 12) loose.
4. Install clutch pump to pump plate with bolts provided. Align clutch pulley to drive pulley (1), tighten pump bolts.
5. Install air compressor belt and tension. Install clutch pump belts, using jackbolt (13) adjust pump plate for proper belt tension. Tighten bolts (6,7, & 12). Connect battery terminal.

**CAUTION:** Check all engine compartment hoses and electrical wiring that may have been disturbed or re-routed during kit installation to be sure that hoses are not kinked, that they do not touch any high temperature item, and that they do not interfere with any linkage components.

**NOTE:** Radiator hose on some older models may need re-routed for clearance around clutch pump.

Cooling line to air compressor may need changed from front port to side port.

CMKN89-4600-A-AB

CMKN89-4600-AH-AB

1989-93 DTA360 & 466 INTERNATIONAL

W/AIR BRAKES ONLY, WO/AC

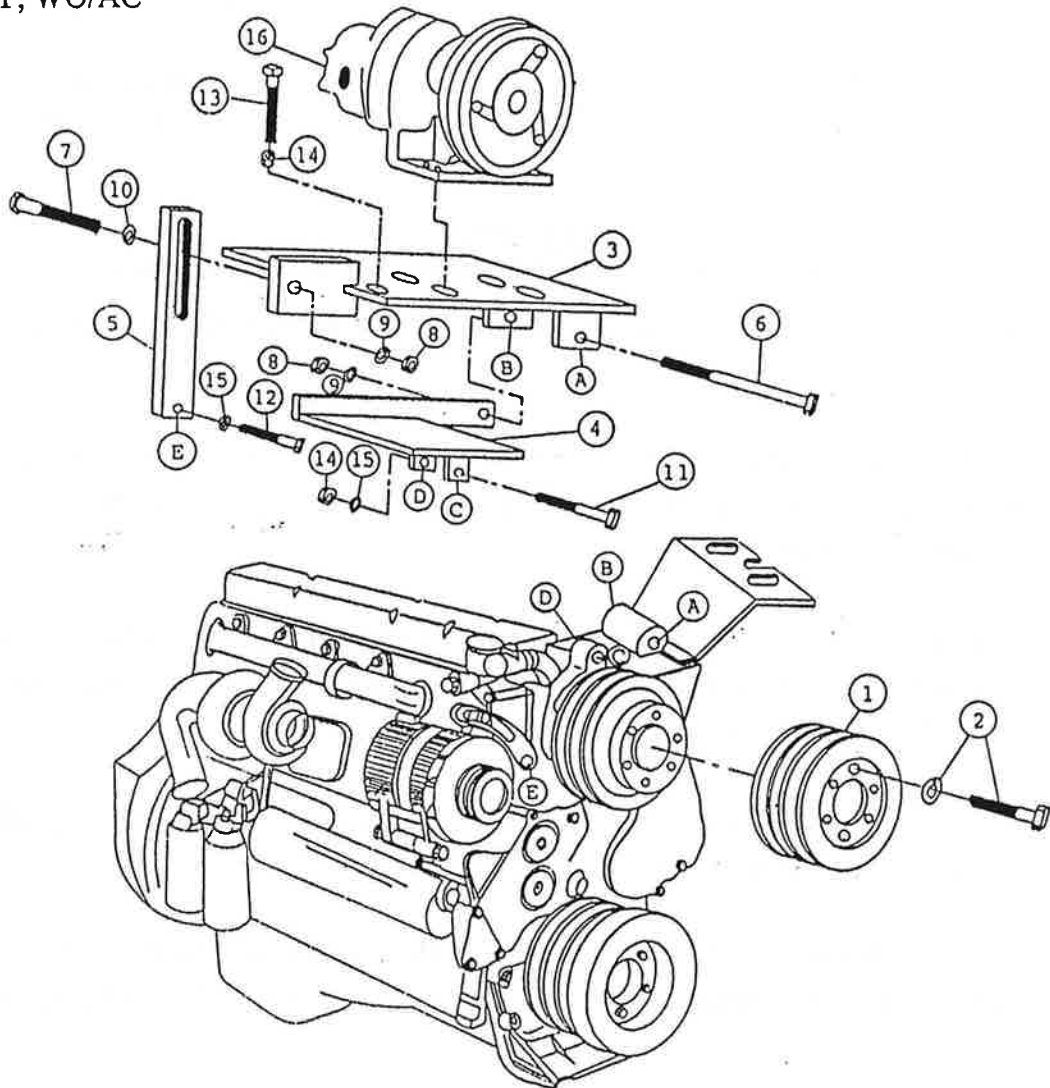

## PARTS LIST

- |                       |  |
|-----------------------|--|
| 1. IPC 432B (1)       | 10. 1/2 FW (1)                         |
| 2. O.E.M. (1)         | 11. 3/8 X 3 NC GR.8 (1)                |
| 3. IMP 431 (1)        | 12. 3/8 X 1 3/4 NC GR. 8 (1)           |
| 4. IMB 431 (1)        | 13. 3/8 X 3 1/2 SQ. Set screw (1)      |
| 5. IMB 432 (1)        | 14. 3/8 NC (2)                         |
| 6. 1/2 X 5 1/2 NC (1) | 15. 3/8 LW (2)                         |
| 7. 1/2 X 1 3/4 NC (1) | 16. AX-46, H.D.: AX-48 (2) (Not Shown) |
| 8. 1/2 NC (2)         | 17. Clutch Pump Assembly (1)           |
| 9. 1/2 LW (2)         | (Sold Separately)                      |