



**Muncie[®]
Power
Products**

CMKN94-4046-XP8-AC

**1994-2001 International
DT408 & 466
W-WO/AC**

INSTALLATION NOTES

1. Disconnect the negative battery cable. Remove the 6-groove A/C belt (if equipped) and the 8-groove accessory belt. Disconnect the wires from the alternator, then remove the alternator from the bracket. Remove the four bolts holding the alternator bracket to the engine and remove the bracket. The bracket will not be reused.
2. Install the new bracket into the O.E.M. alt. bracket location A,B,C,D using bolts (3) with nuts (6) and lockwashers (5), and bolt (7) with nut (9) and lockwasher (8). Tighten bolts securely. It may be necessary to rotate the 45 degree heater hose fitting to clear the bracket. Remove the front bolt (E) from the engine lifting lug. Install the brace (2) onto the back of the bracket with two bolts (4) and lockwashers (5) and to the engine with bolt (10) with a flat and lockwasher (12,11) in location E. Tighten bolts evenly and securely.
3. Install the alternator onto the new bracket using the O.E.M. bolts. Connect the alternator wires. Install the pump onto the bracket with the mounting bolts included with the kit, align the clutch pulley with the drive pulley and then tighten the pump bolts securely. Install the flat idler (16) onto the bracket using bolt (13) and Lockwasher (14). Use the shim washers (15) to align the idler with the drive pulley and clutch pulley. Install the new belt onto the engine as per diagram. Install the A/C belt if equipped.
4. Reroute any hoses, wires, etc. that may be up against hot or moving parts. Reconnect the battery. Start the engine and check the belt to make sure it is tracking down the center of the idler. If it is not running true, adjust the idler in or out, or realign the clutch pump.

CMKN94-4046-XP8-AC

1994-2001 International
DT408 & 466
W-WO/AC

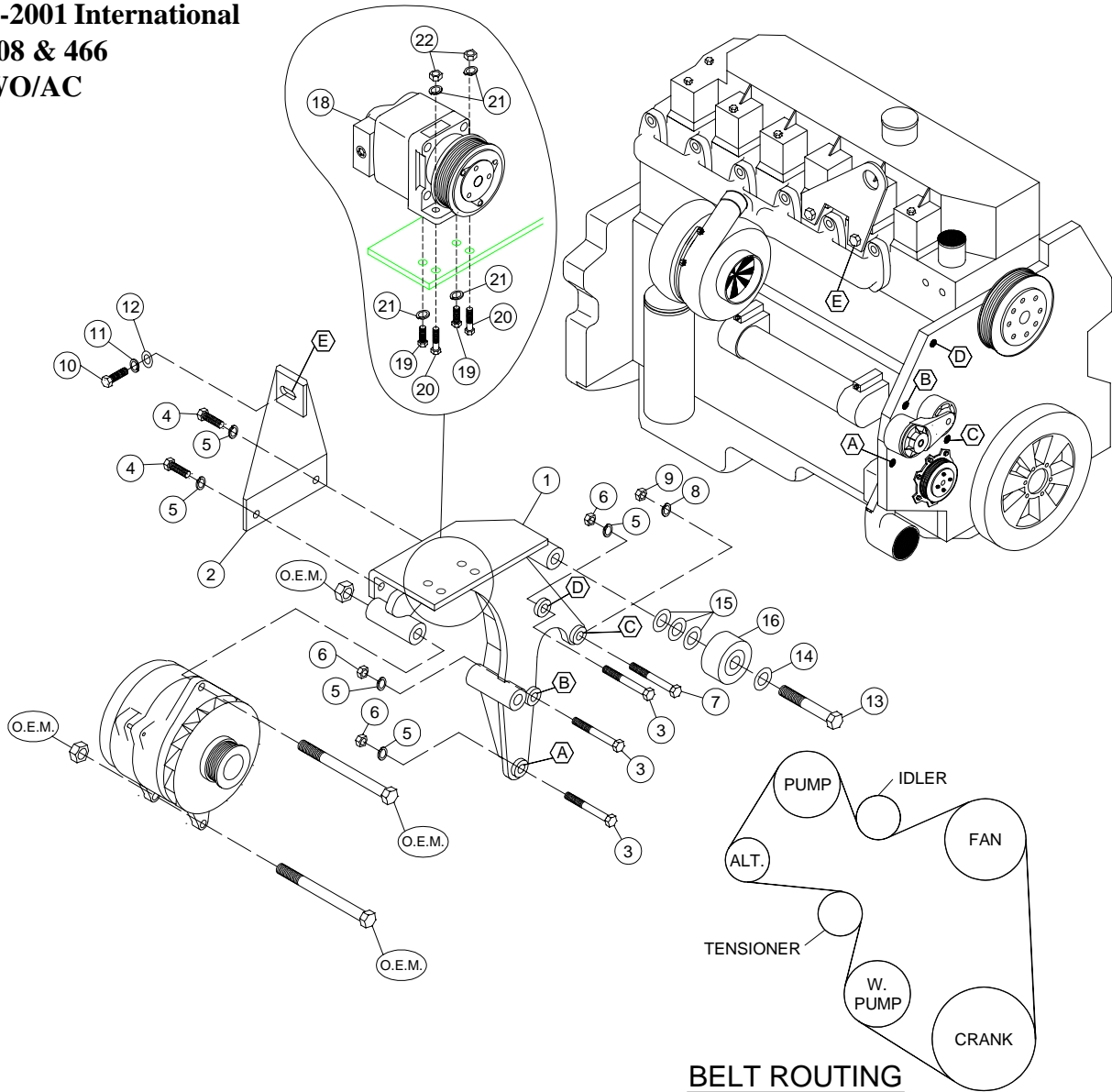

PARTS LIST

- | | |
|--------------------------|------------------------------|
| 1. IMP 471 (1) | 13. 5/8 x 2 1/2 NC (1) |
| 2. IMB 471 (1) | 14. 5/8 LW (1) |
| 3. 10mm x 75mm 1.5 (3) | 15. IPW 14 (5) |
| 4. 10mm x 25mm 1.5 (2) | 16. Dayco 89005 Idler (1) |
| 5. 10mm LW (5) | 17. Belt (Not Shown) (1) |
| 6. 10mm 1.5 NUT (3) | Dayco 5080903 |
| 7. 8mm x 70mm 1.25 (1) | 18. Clutch Pump Assembly (1) |
| 8. 8mm LW (1) | (Sold Separately) |
| 9. 8mm 1.25 NUT (1) | 19. 3/8 x 1 NC (2) |
| 10. 12mm x 35mm 1.75 (1) | 20. 3/8 x 1 1/2 NC (2) |
| 11. 12mm LW (1) | 21. 3/8 LW (4) |
| 12. 12mm FW (1) | 22. 3/8 NC (2) |