



**Muncie[®]
Power
Products**

CVKC03-5360-XP6-AC

**2003-2008 CHEVY
1500-3500 G-Series Van
5.3, 6.0 VORTEC V-8
W-WO/AC
W/O EGR Valve**

INSTALLATION NOTES

1. Disconnect the negative battery cable. Remove the air intake duct. Removing the fan shroud and fan is not necessary, but does make installation easier. Fan nut has right hand threads. Remove the O.E.M. belt and tensioner, they will not be reused. Remove oil fill tube and cut off stabilizer bracket flush with tube.
2. Install the pump bracket (1) onto the engine at locations A, B, & C with bolts (3,4) & LW's (2). Torque to 35 ft. lbs. Install the tensioner (9) with bolt (10) and torque to 25-30 ft. lbs. Install clutch pump onto the pump bracket and align the clutch pulley with the OEM pulley. Air conditioner line may need to be bent out of the way. Be sure to leave 2" clearance between clutch and air conditioner line.
3. Install the new belt and route it according to the diagram. It is easiest to install the belt over the O.E.M. idler last. Install the fan and fan shroud if removed.
4. Install tube bracket (5) with bolts (6) and lockwashers (8). Bolt transmission dipstick tube to bottom hole of tube bracket using bolt (6), nut (7), and lockwasher (8). Bend the mount for the engine oil dipstick to line up with the top hole on tube bracket. Reinstall oil fill tube and engine oil dipstick, as shown on diagram, using Adel clamp (11), bolt (6), nut (7), and lockwasher (8).
5. Reconnect the battery cable. Run the engine and check for proper belt tracking.

NOTE: Check all engine compartment vacuum hoses and electrical wiring that may have been disturbed or re-routed during kit installation to be sure that hoses are not kinked, do not touch any high temperature item, and do not interfere with any linkage components.

NOTE: Recommended no larger than 1.00 CID pump or 7 HP.

CVKC03-5360-XP6-AC

2003-2008 Chevy
1500-3500 G-Series Van
5.3, 6.0 VortecV-8
W-WO/AC
W/O EGR Valve

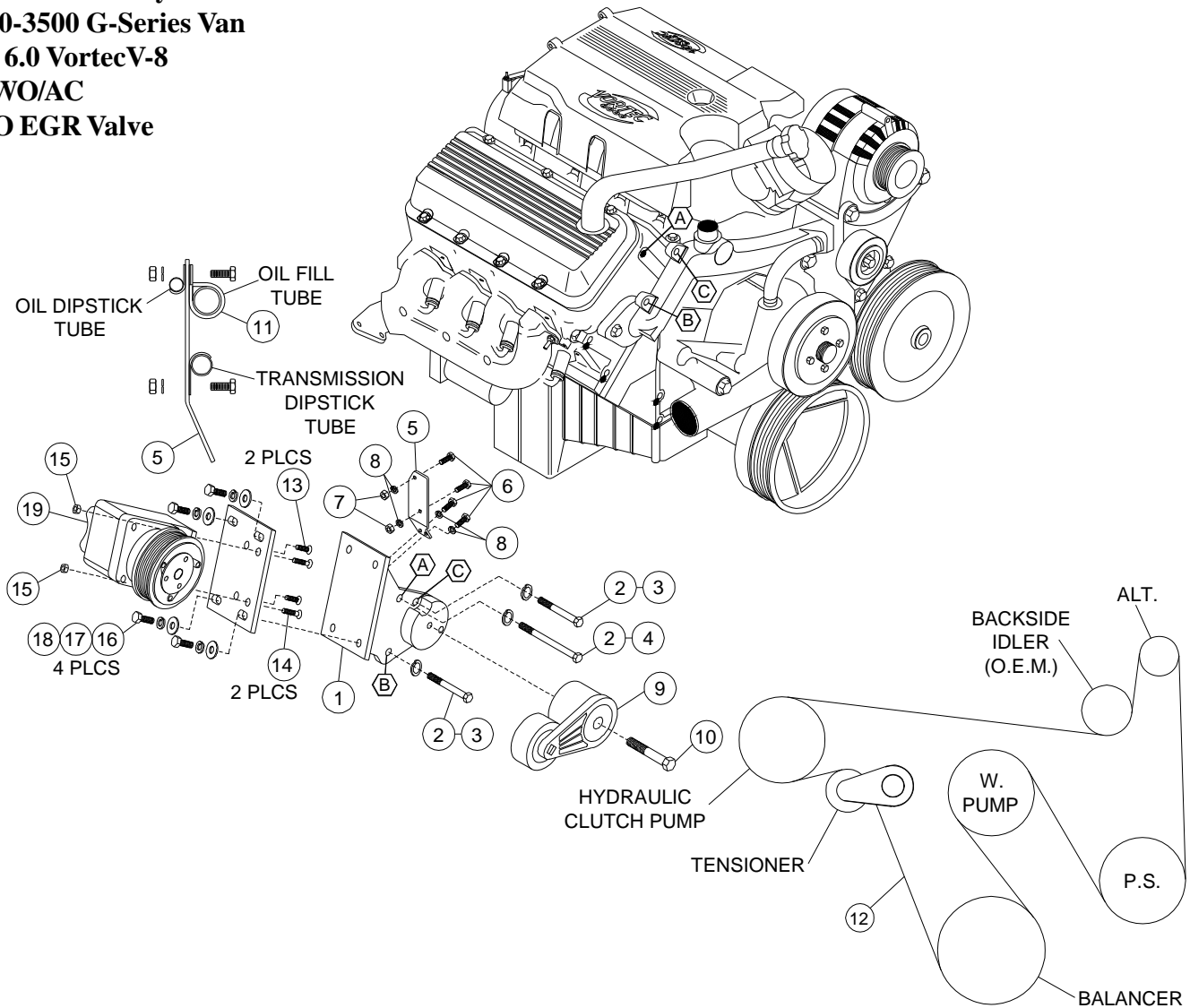

BELT ROUTING

PARTS LIST

- | | |
|----------------------|---------------------------------------|
| 1. VCMB 38 I6 (1) | 8. 1/4 LW (4) |
| 2. 10mm LW (3) | 9. 89203 TIPCS (1) |
| 3. 10mm x 65mm (2) | 10. 10mm x 60mm 1.5 (1) |
| 4. 10mm x 130mm (1) | 11. 1" Adel Clamp (1) |
| 5. VCMB 382 | 12. Clutch Pump (1) (Sold Separately) |
| 6. 1/4 x 3/4 UNC (4) | 13. 5061105 Dayco Belt (1) |
| 7. 1/4 Nut (2) | |