



Muncie<sup>®</sup>  
Power  
Products

CVKF85-3035-A

1982-87 Ford Van E-150,250,350

351 WO/AC

### INSTALLATION NOTES

---

1. Disconnect battery terminal. Loosen belts, remove fan and shroud. If equipped with rubber splash guard under radiator, remove clips and fold out of the way for access to crankshaft pulley.
2. Remove 4 bolts and washers from pulley on front of crankshaft. Do not remove large center bolt. Install drive pulley (1) with provided bolts (2) and washers. **CAUTION:** Be sure new bolts have same threads as O.E.M. bolts removed.
3. Remove fan studs and replace with provided studs (5). Install fan spacer (4), fan and shroud, tighten securely. Replace splash guard if removed.
4. Remove power steering pump from original position, discard aluminum spacer between power steering pump and head. Remove nut holding dip stick tube to exhaust stud. Remove ignition coil, lay it aside. Remove bolt at location "A".
5. Install mounting bracket (8) with pump plate (9) attached, using bolt (14) at location "D", do not tighten. With SAGINAW pump - install bolt (14) at location "E", do not tighten. Use spacer (11) with bolts (17) at location "A". Use spacer (11) with bolts (13) at location "B" with SAGINAW pump, location "C" with FORD pump, install power steering pump. Tighten bolts (14 & 17), tension power steering pump belt and tighten bolt (13).
6. Mount clutch pump (30) to pump plate with bolts (18). Make sure clutch pulley is in line with drive pulley (1). Tighten pump bolts (18) securely.
7. Install idler pulley (23) using spacers as required to align with clutch and drive pulleys. Tighten securely.
8. Install pump drive belts (29), adjust pump plate (9) for proper belt tension. Tighten bolts (16 & 18) on pump plate.
9. Using spacer nut (12) secure dip stick. Remove and turn bracket around on coil, secure coil to location "G". Connect battery terminal.
10. **CAUTION:** Check all engine compartment hoses and electrical wiring that may have been disturbed or re-routed during kit installation to be sure that hoses are not kinked, that they do not touch any high temperature item, and that they do not interfere with any linkage components.

**NOTE:** This kit is designed to operate successfully with the standard fan supplied by FORD. Due to O.E.M. assembly tolerances, visually make certain that there is adequate clearance between fan and radiator and also fan and drive pulley (1). It may be necessary to use a longer spacer for pulley clearance. If there is little clearance to the radiator, check with your FORD dealer to insure that it will not flex into the radiator - before operating. Or move radiator ahead for clearance.

# CVKF85-3035-A.

1982-87 Ford Van E-150,250,350  
351 WO/AC

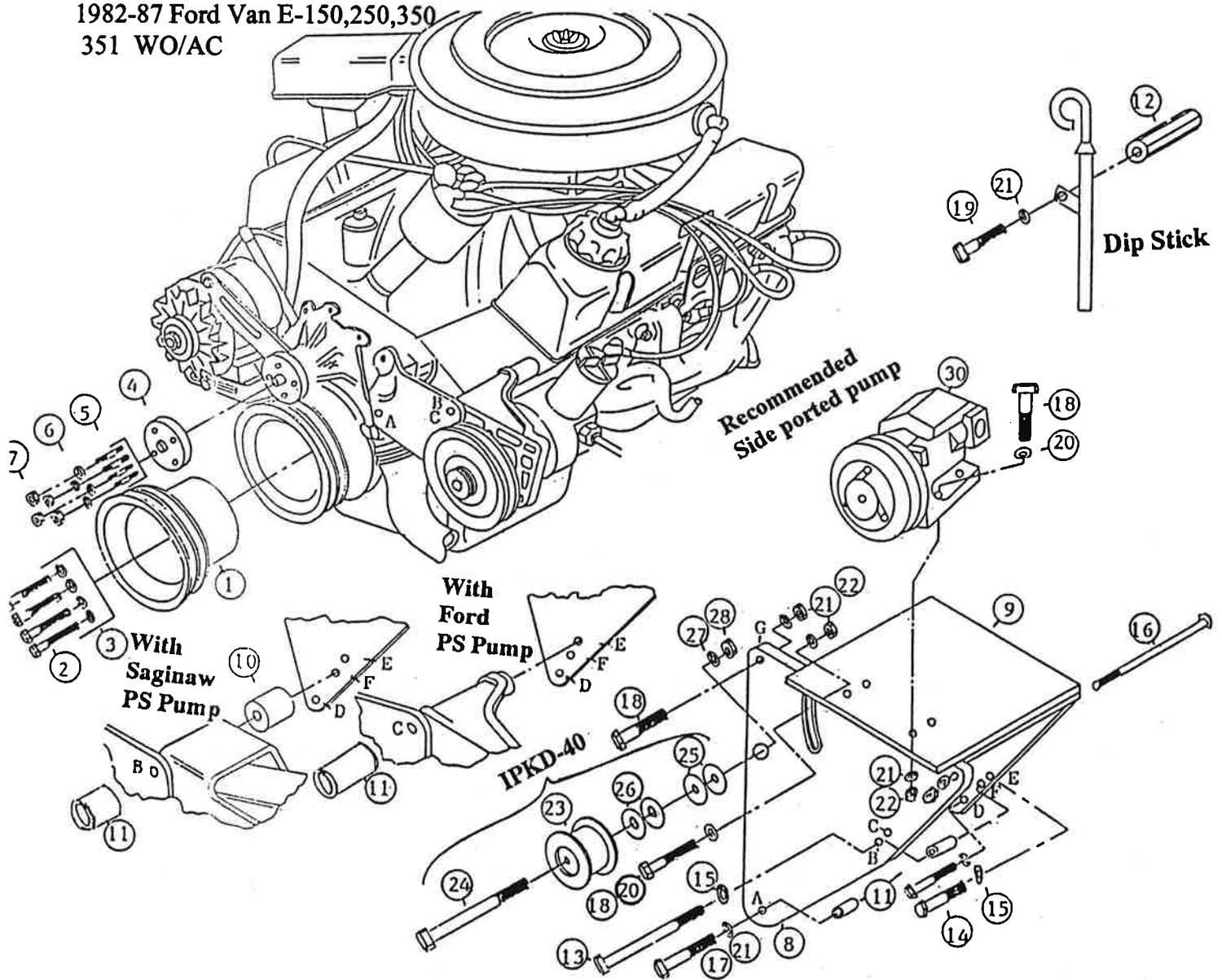

## PARTS LIST

- |                               |                              |
|-------------------------------|------------------------------|
| 1. FPC 322 (1)                | 17. 3/8 X 3 1/4 NC (1)       |
| 2. 3/8 X 1 3/4 NC (4)         | 18. 3/8 X 1 1/2 NC (6)       |
| 3. 3/8 LW (4)                 | 19. 3/8 X 3/4 NC (1)         |
| 4. FSO 508 & FSO 608 (1)      | 20. 3/8 FW (6)               |
| 5. 5/16 X 2 1/2 ST (4)        | 21. 3/8 LW (9)               |
| 6. 5/16 LW (4)                | 22. 3/8 NC (7)               |
| 7. 5/16 NC (4)                | 23. IPCD (1)                 |
| 8. VFB 321 (1)                | 24. 5/8 X 4 NC (1)           |
| 9. VFP 321 (1)                | 25. 5/8 FW (12)              |
| 10. SP165-1.281 (1) (SAG. PS) | 26. IPW14 (5)                |
| 11. SP88-2.000 (2)            | 27. 5/8 LW (1)               |
| 12. SP3/8 NC-1.750 (1)        | 28. 5/8 NC (1)               |
| 13. 7/16 X 8 NC (1) (SAG. PS) | 29. AX-59 (2) (Not Shown)    |
| 14. 7/16 X 1 1/2 NC (2)       | 30. Clutch Pump Assembly (1) |
| 15. 7/16 LW (2)               | (Sold Separately)            |
| 16. 3/8 X 8 NC (1)            |                              |