

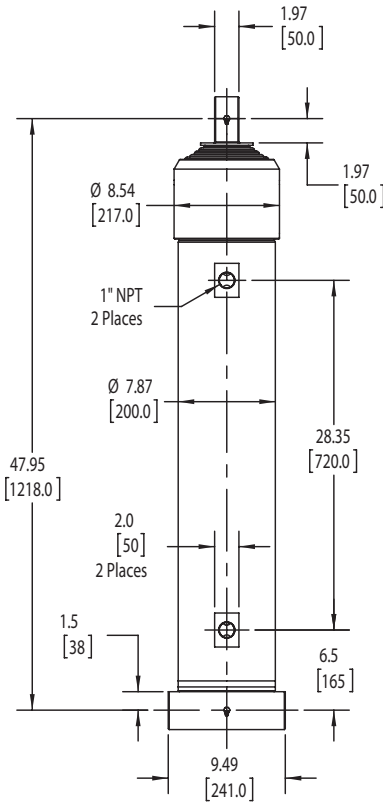

**Muncie[®]
Power
Products**

SINGLE ACTING TELESCOPIC CYLINDER

MODEL NO: 8-5-169-A00

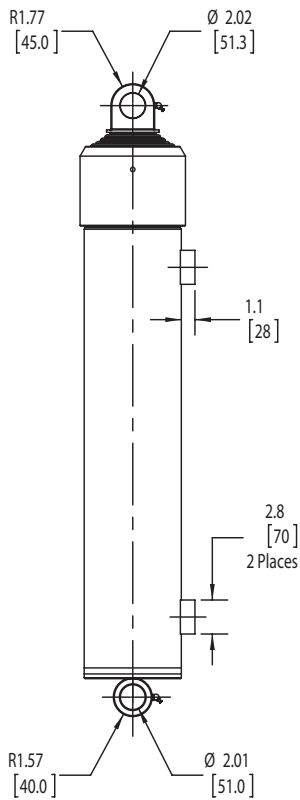

Mounting Dimensions: 47.95" (1218 mm) + 0.75" (19.1 mm) min. pull out **Max Pressure: 2750 PSI/ 189.7 Bar (Rated for 2900 PSI/ 200 Bar)**

MODEL NO: 8-5-169-A00						Weight: 425 lb. (192.8 kg)	Seal Kit Part No.: GSK-85-00
Extension	1	2	3	4	5	Number of Stages: 5	
Diameter (in./mm)	6.85 / 174	6.06 / 154	5.31 / 135	4.57 / 116	3.86 / 98		
Stroke (in./mm)	33.07 / 840	33.46 / 850	33.78 / 858	34.09 / 866	34.54 / 877	Total Stroke: 168.94 in (4291 mm)	
Thrust (ton/kN)	50.7 / 451	39.7 / 353	30.4 / 270	22.6 / 201	16.1 / 143	Thrust based on 2750 PSI (189.7 Bar)	
Oil (gal/L)	5.28 / 20.0	4.18 / 15.8	3.24 / 12.3	2.42 / 9.2	1.75 / 6.6	Total Oil: 16.87 gal (63.85 L)	

User responsibility: Incorrect selection or incorrect use of the here described component and its related items may cause death, personal injury and property damage. All the information here reported are intended for further investigation by users with technical knowledge. The user, as manufacturer of the completed machinery which will incorporate the here described components, is the solely responsible for the final selection of the components. The user must carry out necessary research and tests on components to determine whether, by its design and construction, all performance, endurance, maintenance, safety and warning requirements are met. The user must assure the compliance of the completed machinery with all appropriate laws, directives, norms, industry standards. The normal application of telescopic cylinders is to lift up tipping bodies, loaded with different materials, and consequently discharge this material while the cylinder is being extended.

The cylinder has been designed to provide only a linear pushing force. The cylinder is not a structural member and must not be used as a stabilizer or be subject to side or pulling load. The cylinder will not prevent the dump body or trailer from rollover or lateral tilt. The body weight plus the max payload are the max tipping weight that can be raised by the cylinder. This value, calculated at the max pressure, is a rough indication of the tipping power of the cylinder and must be used as a first criteria for selection of the cylinder. The real tipping mass can only be calculated by the design engineer of the completed machinery, and must take into account the geometry of the dump body, operating conditions and all reasonably foreseeable uses. **Never exceed maximum thrust.**

When selecting a hydraulic cylinder for replacement. It is the responsibility of the purchaser and installer/ user to verify that all dimensions, mounting, and performance features of the replacement cylinder are appropriate for the application.

Refer to www.munciepower.com for additional info on maintenance, service, general precautions, and warranty info
Never exceed the herein specified limits of the cylinder.

Cylinder rated pressure reflect only the capability of the pressure-containing envelope and not the force transmitting capability of mounting configurations. Never exceed maximum pressure.

The ordinary use of a telescopic cylinder will not require any coating since the stages are exposed to atmospheric agents only during the tip-up operation, if duration is below 2 hours. Surface coatings can be supplied on request. Muncie Power Products Inc. warranty does not apply to any kind of corrosion or coated or non-coated parts.

When closed, leave the tipping control in descent position. The exposed surface of the first moving stage may eventually rust due to exposure to the atmosphere, but this will not affect the functionality of the cylinder.

Maximum extension speed less than 0.656 ft/s (0.2 m/s).

Hydraulic oil temperature range allowable between -40°F to 212°F (-40°C to 100°C).

If the cylinder must be stored, store them in a dry place. Do not expose to rain. Do not store the cylinder for more than 6 (six) months. User shall pay attention to stroke length, loading and cylinder mounting in order to avoid bending or buckling of the cylinder at any position.

Chrome coating type CRN (40 h corrosion test ISO9227-rating 9 ISO10289 - minimum thickness 15 µm) on smallest, 3.86 in (98 mm) stage.

REMARKS

REVISIONS